

### Features

- Low saturation voltage

### Equivalent Circuit

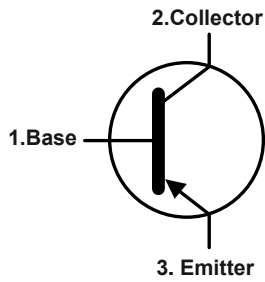

### SOT-89

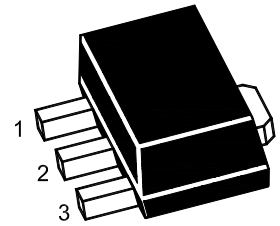

1.Base 2.Collector 3. Emitter

### Marking Code :

2SB1132SQ-P : 1132-P

2SB1132SQ-Q : 1132-Q

2SB1132SQ-R : 1132-R

### Absolute Maximum Ratings

Ratings at 25°C ambient temperature unless otherwise specified.

Parameter	Symbol	Value	Unit
Collector Base Voltage	$-V_{CBO}$	40	V
Collector Emitter Voltage	$-V_{CEO}$	32	V
Emitter Base Voltage	$-V_{EBO}$	5	V
Collector Current	$-I_C$	1	A
Peak Collector Current	$-I_{CM}$	2	A
Maximum Power Dissipation	$P_D$	500	mW
Junction Temperature	$T_J$	150	°C
Storage Temperature Range	$T_{STG}$	-55 to +150	°C



### Electrical Characteristics (T<sub>A</sub>=25°C)

Parameter	Symbol	Min.	Typ.	Max.	Unit
DC Current Gain at V <sub>CE</sub> = -2 V, I <sub>C</sub> = -500 mA    Current Gain Group	P Q R H <sub>FE</sub>	82 120 180	-- -- --	180 270 390	--
Collector Base Cutoff Current at V <sub>CB</sub> = -20V	-I <sub>CB0</sub>	--	--	0.5	μA
Emitter Base Cutoff Current at V <sub>EB</sub> = -4 V	-I <sub>EBO</sub>	--	--	0.5	μA
Collector Base Breakdown Voltage at I <sub>C</sub> = -50 μA	-V <sub>(BR)CBO</sub>	40	--	--	V
Collector Emitter Breakdown Voltage at I <sub>C</sub> = -1 mA	-V <sub>(BR)CEO</sub>	32	--	--	V
Emitter Base Breakdown Voltage at I <sub>E</sub> = -50 μA	-V <sub>(BR)EBO</sub>	5	--	--	V
Collector Emitter Saturation Voltage at I <sub>C</sub> = -500 A, I <sub>B</sub> = -50 mA	-V <sub>CE(sat)</sub>	--	0.2	0.5	V
Transition Frequency at V <sub>CE</sub> = -5 V, I <sub>C</sub> = -50 mA, f=30 MHz	F <sub>T</sub>	--	150	--	MHz
Output Capacitance at V <sub>CB</sub> = -10 V, I <sub>E</sub> = 0, f = 1 MHz	C <sub>ob</sub>	--	20	30	pF

### Typical Characteristic Curves

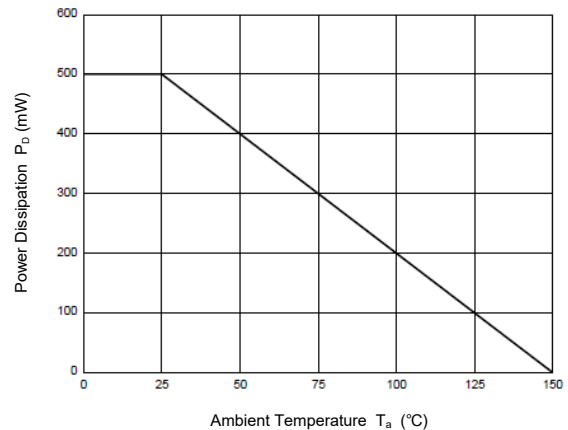
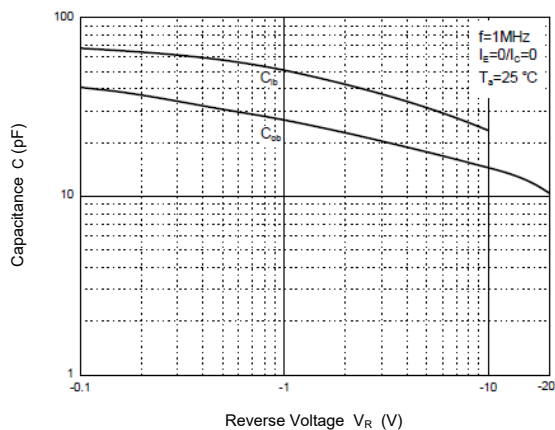
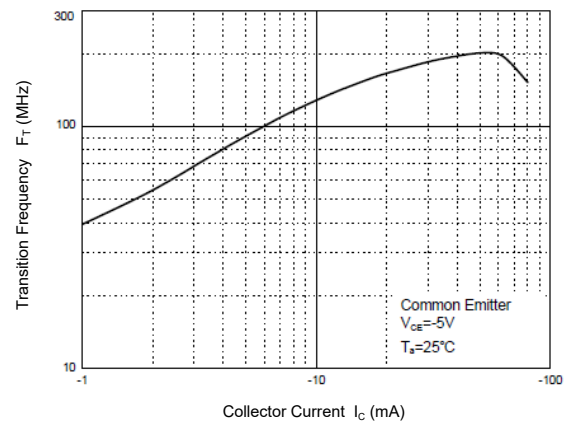
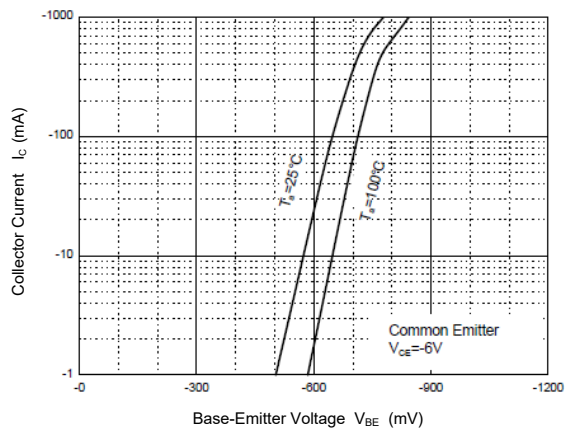
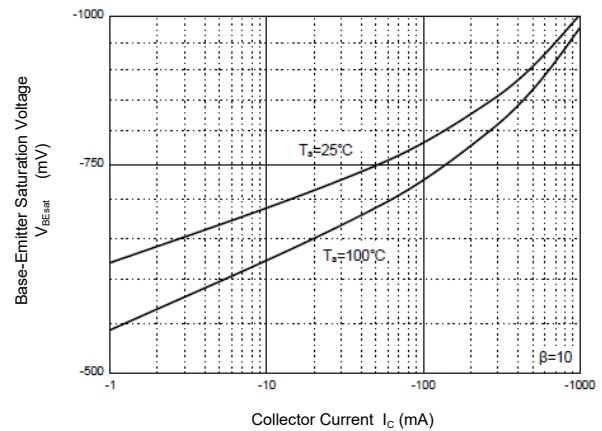
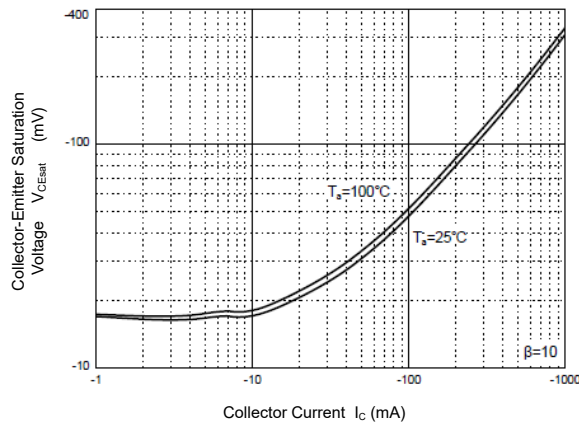
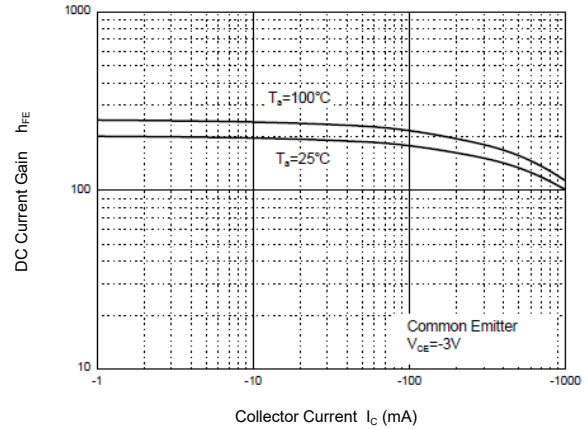
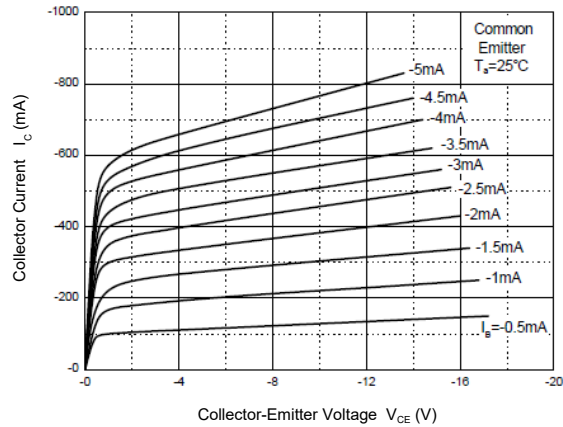

### Package Outline

SOT-89

Dimensions in mm

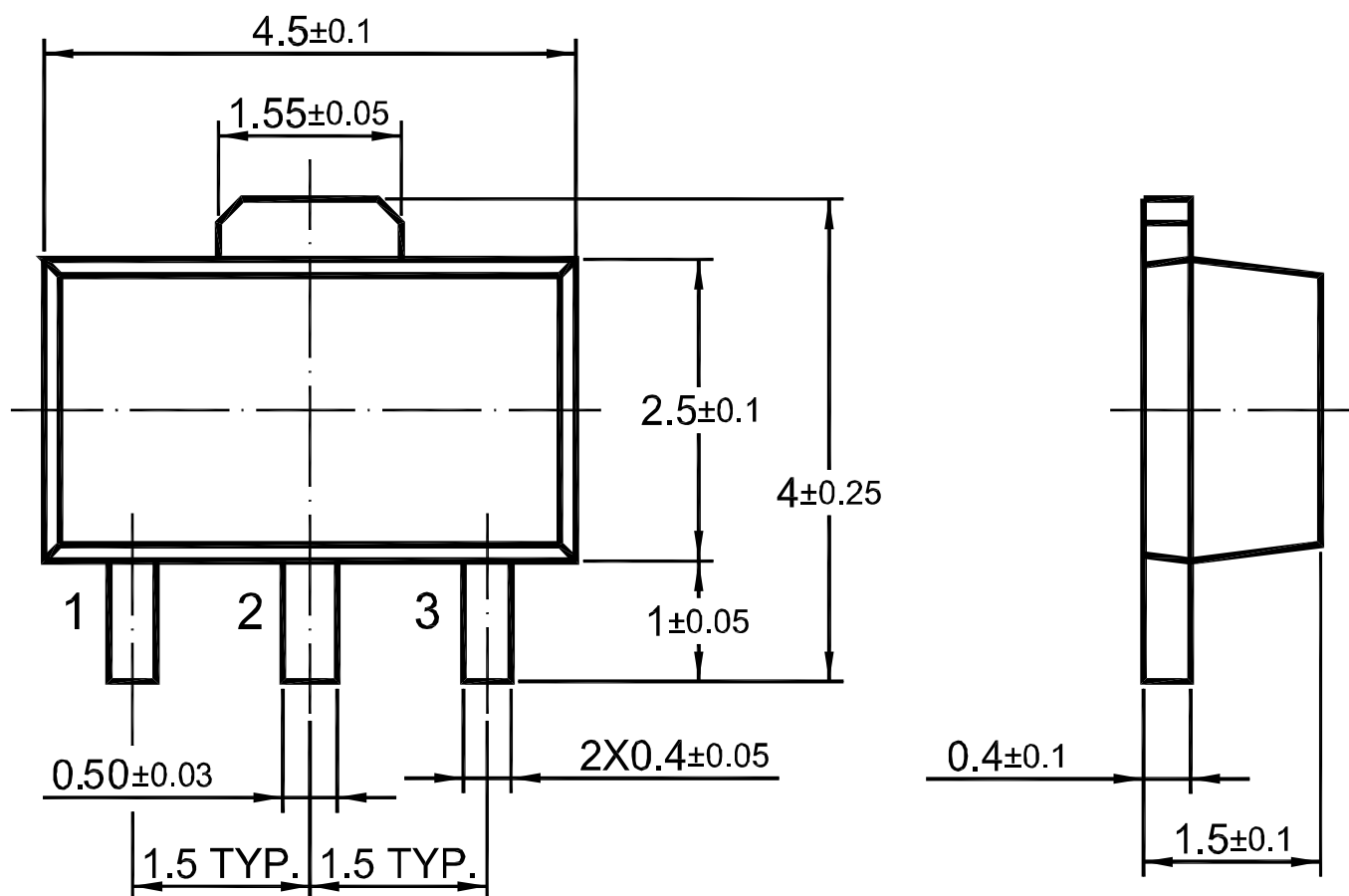

### Ordering Information

Device	Package	Shipping
2SB1132SQ	SOT-89	1,000PCS/Reel&7inches
		3,000PCS/Reel&13inches

### Conditions of Soldering and Storage

#### ◆ Recommended condition of reflow soldering



Recommended peak temperature is over 245 °C. If peak temperature is below 245 °C, you may adjust the following parameters:

- Time length of peak temperature (longer)
- Time length of soldering (longer)
- Thickness of solder paste (thicker)

#### ◆ Conditions of hand soldering

- Temperature: 370 °C
- Time: 3s max.
- Times: one time

#### ◆ Storage conditions

- **Temperature**  
5 to 40 °C
- **Humidity**  
30 to 80% RH
- **Recommended period**  
One year after manufacturing

### Package Specifications

- The method of packaging (1,000PCS/Reel&7inches)

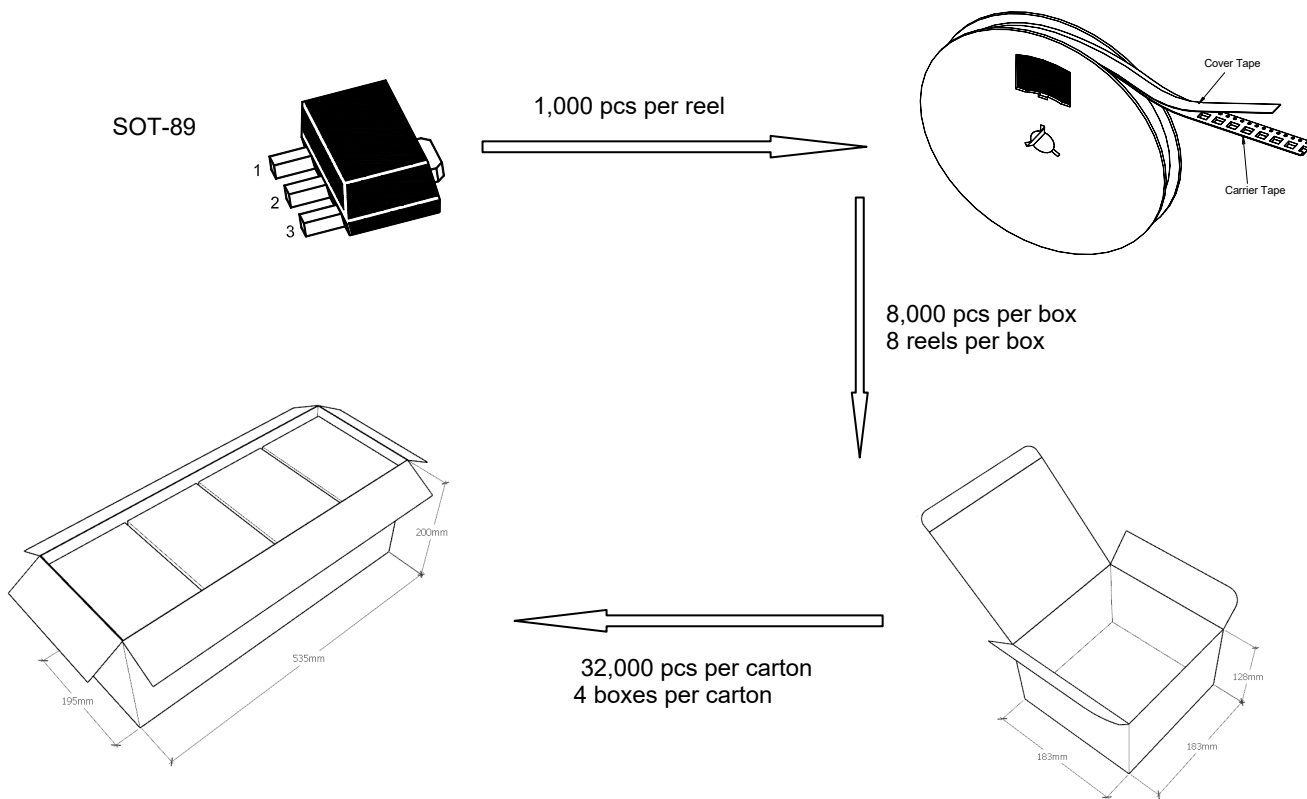

### ◆ Embossed tape and reel data

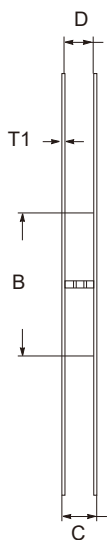
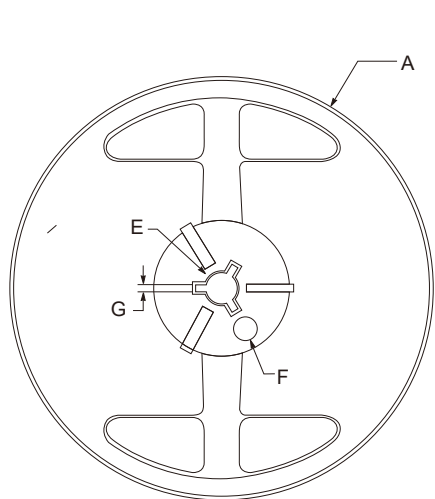

symbol	Value(unit:mm)
A	$\Phi 179 \pm 1$
B	$60.5 \pm 0.2$
C	$15.3 \pm 0.3$
D	12.5~13.7
E	$\Phi 13.5 \pm 0.2$
F	$\Phi 10.0 \pm 0.2$
G	$2.7 \pm 0.2$
T1	$1.0 \pm 0.2$

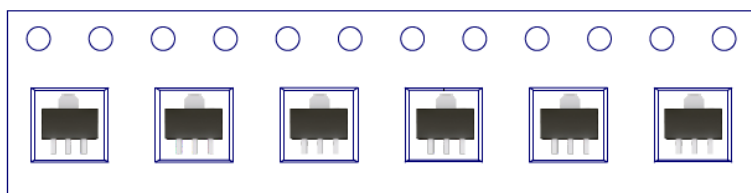

### Package Specifications

- The method of packaging (3,000PCS/Reel&13inches)

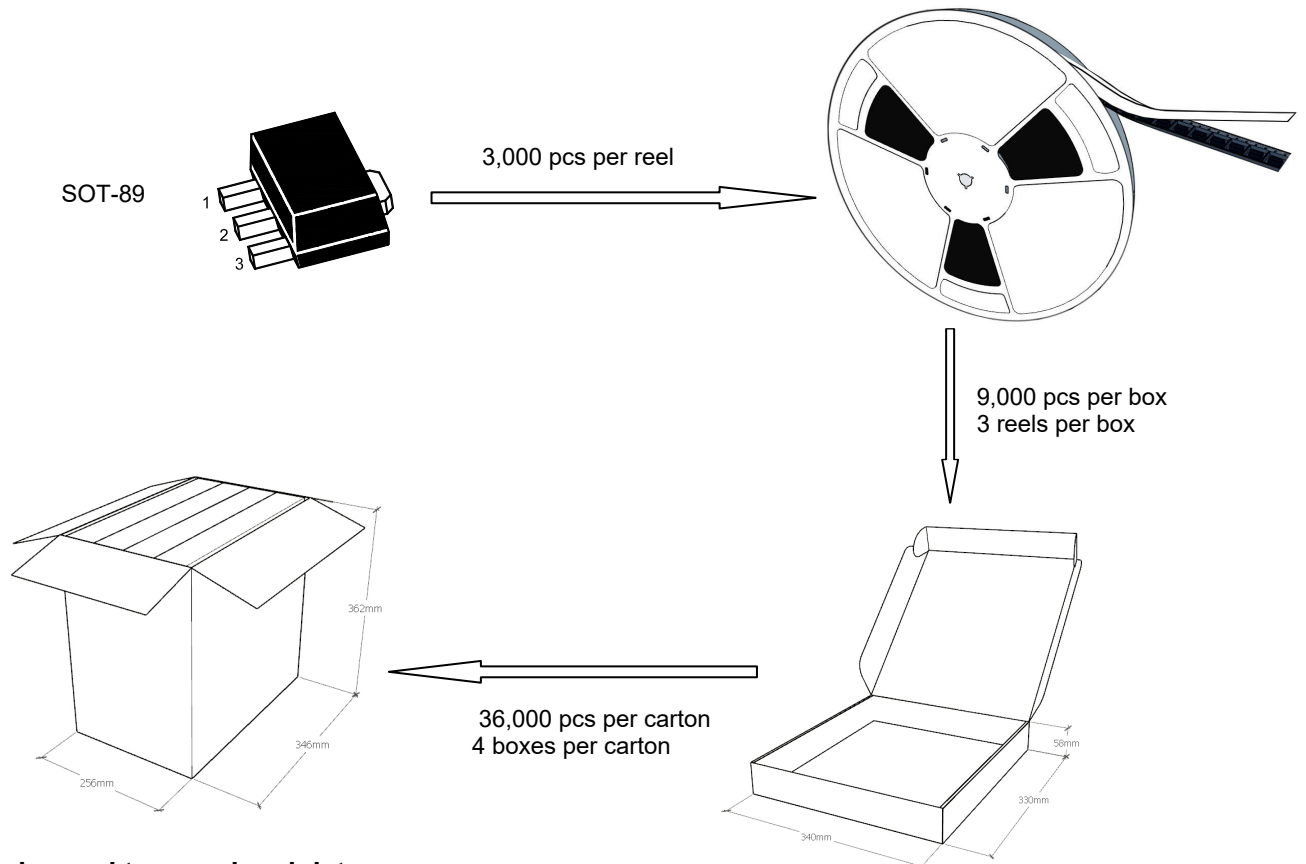

### ◆ Embossed tape and reel data

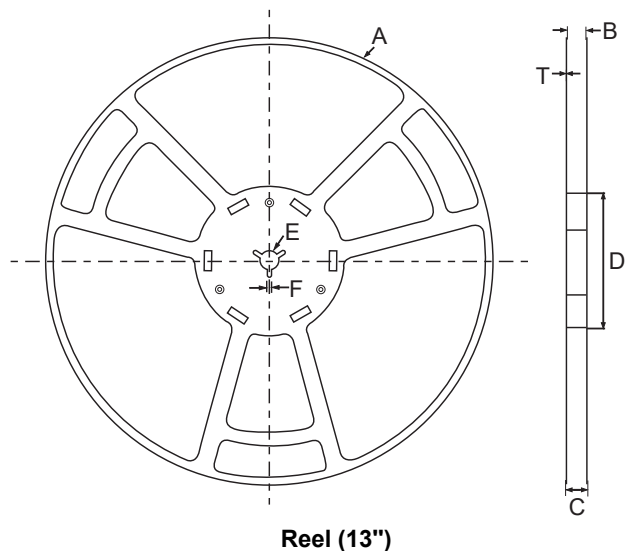

symbol	Value(unit:mm)
A	$\Phi 330 \pm 1$
B	$12.7 \pm 0.5$
C	$16.5 \pm 0.3$
D	$\Phi 99.5 \pm 0.5$
E	$\Phi 13.6 \pm 0.3$
F	$2.8 \pm 0.3$
T1	$1.9 \pm 0.2$

