

### Features

- High breakdown voltage
- Low collector saturation voltage
- High total power dissipation

### Equivalent Circuit

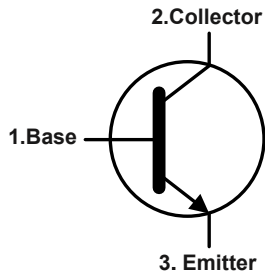

### SOT-89

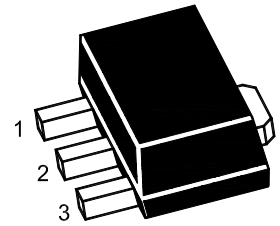

1.Base 2.Collector 3. Emitter

### Marking Code :

2SD1616ASQ-L : 1616AL  
 2SD1616ASQ-K : 1616AK  
 2SD1616ASQ-U : 1616AU

### Absolute Maximum Ratings

Ratings at 25°C ambient temperature unless otherwise specified.

Parameter	Symbol	Value	Unit
Collector Base Voltage	$V_{CB0}$	120	V
Collector Emitter Voltage	$V_{CE0}$	60	V
Emitter Base Voltage	$V_{EB0}$	6	V
Collector Current	$I_C$	1	A
Maximum Power Dissipation	$P_D$	0.5	W
Junction Temperature	$T_J$	150	°C
Storage Temperature Range	$T_{STG}$	-55 to +150	°C



### Electrical Characteristics (T<sub>A</sub>=25°C)

Parameter	Symbol	Min.	Max.	Unit
DC Current Gain at V <sub>CE</sub> = 2 V, I <sub>C</sub> = 100 mA      Current Gain Group	L K U	135 200 300	270 400 600	--
Collector Base Cutoff Current at V <sub>CB</sub> = 60 V	I <sub>CBO</sub>	--	0.1	μA
Emitter Base Cutoff Current at V <sub>EB</sub> = 6 V	I <sub>EBO</sub>	--	0.1	μA
Collector Base Breakdown Voltage at I <sub>C</sub> = 100 μA	V <sub>(BR)CBO</sub>	120	--	V
Collector Emitter Breakdown Voltage at I <sub>C</sub> = 1 mA	V <sub>(BR)CEO</sub>	60	--	V
Emitter Base Breakdown Voltage at I <sub>E</sub> = 100 μA	V <sub>(BR)EBO</sub>	6	--	V
Collector Emitter Saturation Voltage at I <sub>C</sub> = 1 A, I <sub>B</sub> = 50 mA	V <sub>CE(sat)</sub>	--	0.3	V
Base Emitter Saturation Voltage at I <sub>C</sub> = 1 A, I <sub>B</sub> = 50 mA	V <sub>BE(sat)</sub>	--	1.2	V
Base Emitter On Voltage at V <sub>CE</sub> = 2 V, I <sub>C</sub> = 50 mA	V <sub>BE(on)</sub>	--	0.7	V
Transition Frequency at V <sub>CE</sub> = 2 V, I <sub>C</sub> = 100 mA	F <sub>T</sub>	100	--	MHz
Output Capacitance at V <sub>CB</sub> = 10 V, f = 1 MHz	C <sub>ob</sub>	--	19	pF

### Typical Characteristic Curves

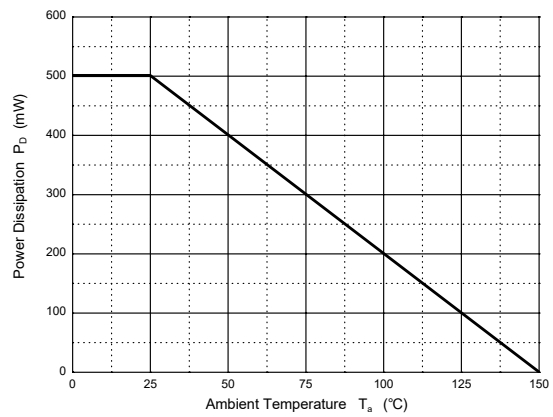
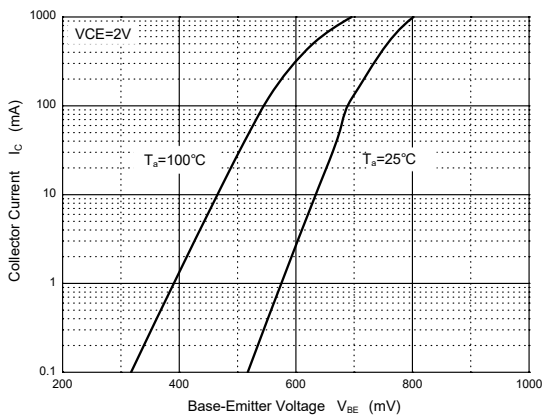
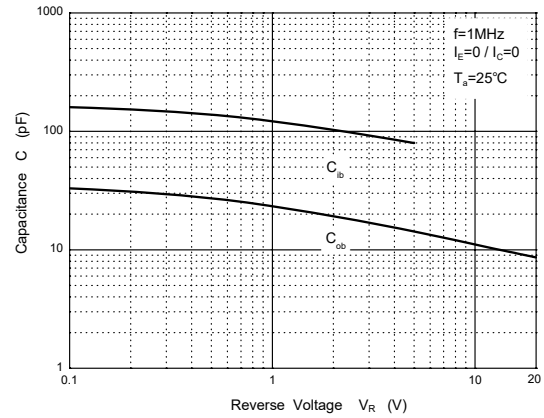
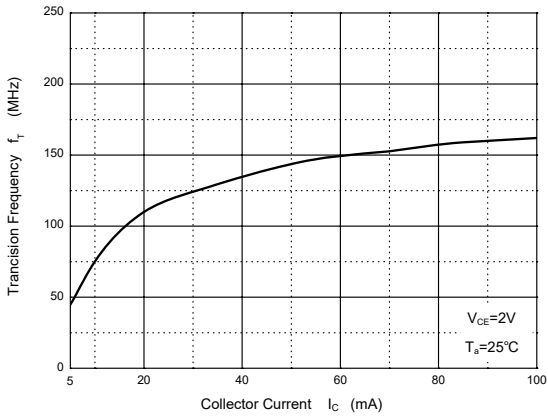
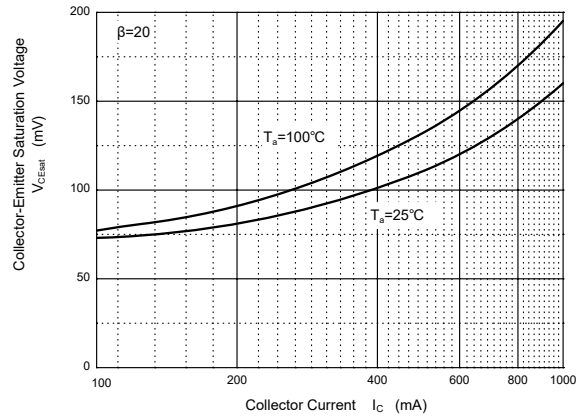
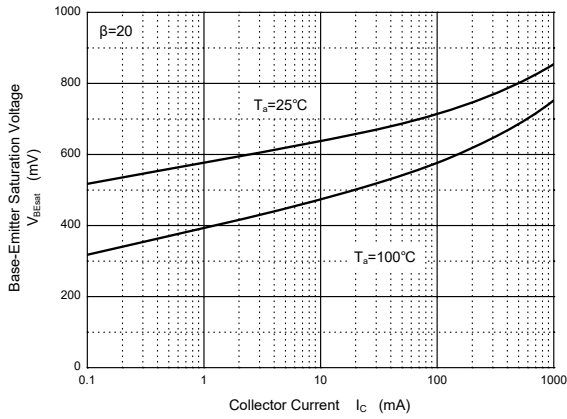
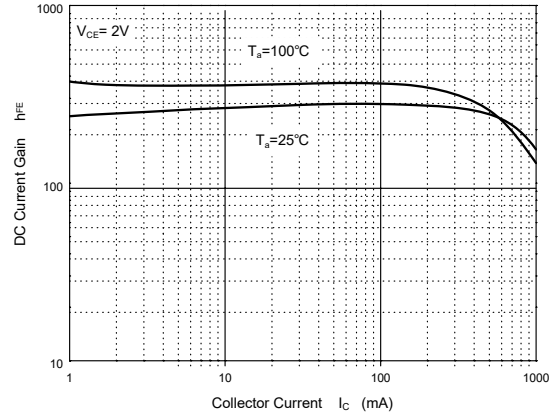
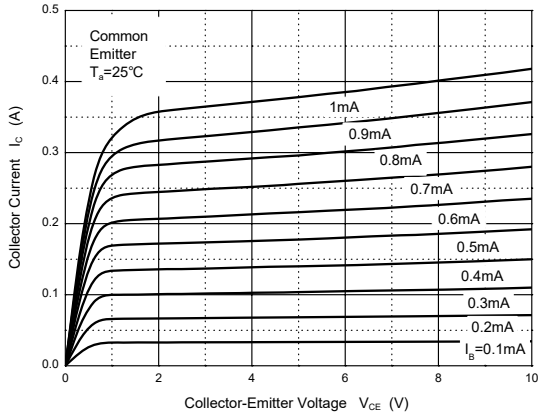

### Package Outline

SOT-89

Dimensions in mm

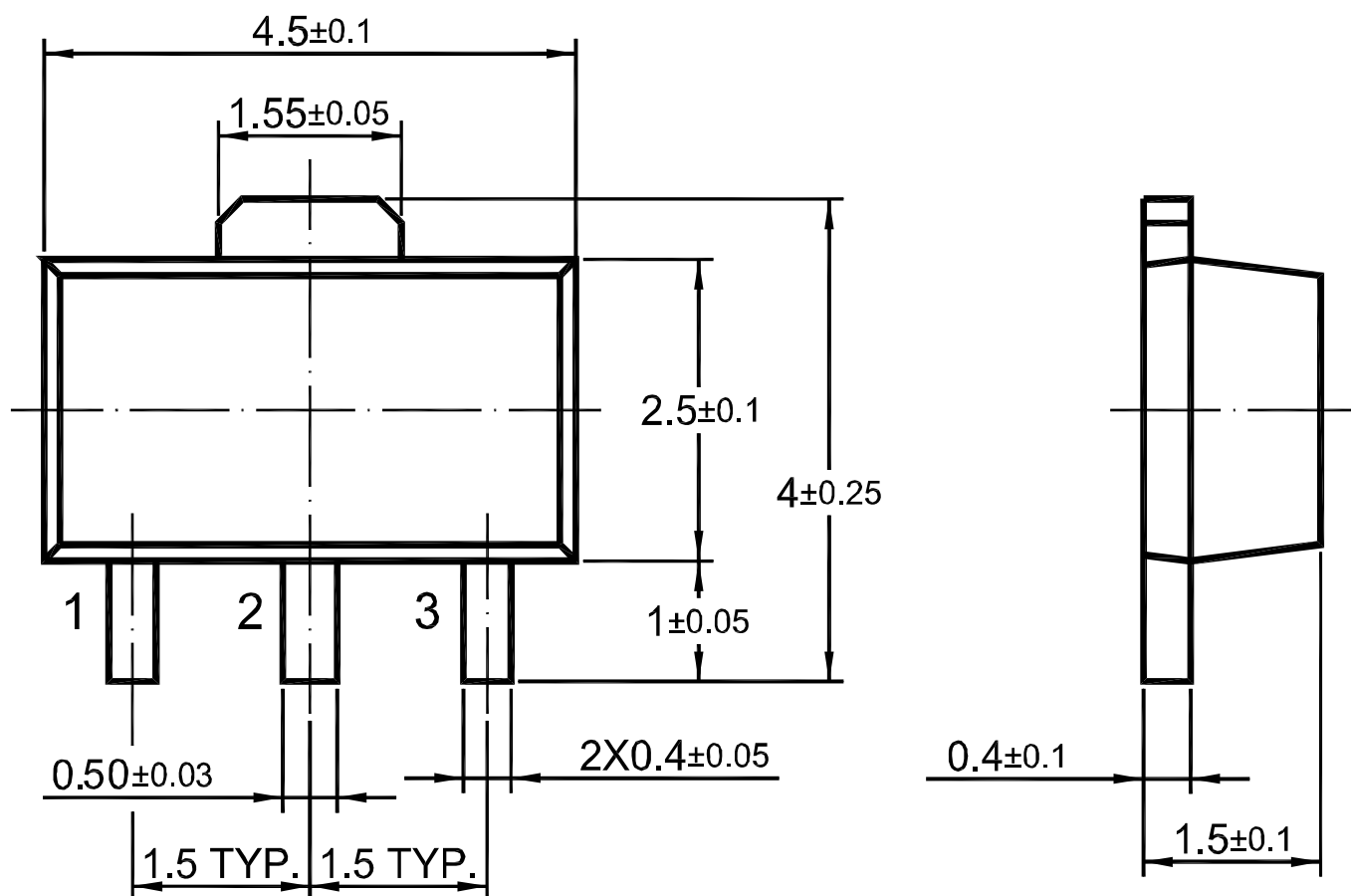

### Ordering Information

Device	Package	Shipping
2SD1616ASQ	SOT-89	1,000PCS/Reel&7inches
		3,000PCS/Reel&13inches

### Conditions of Soldering and Storage

#### ◆ Recommended condition of reflow soldering

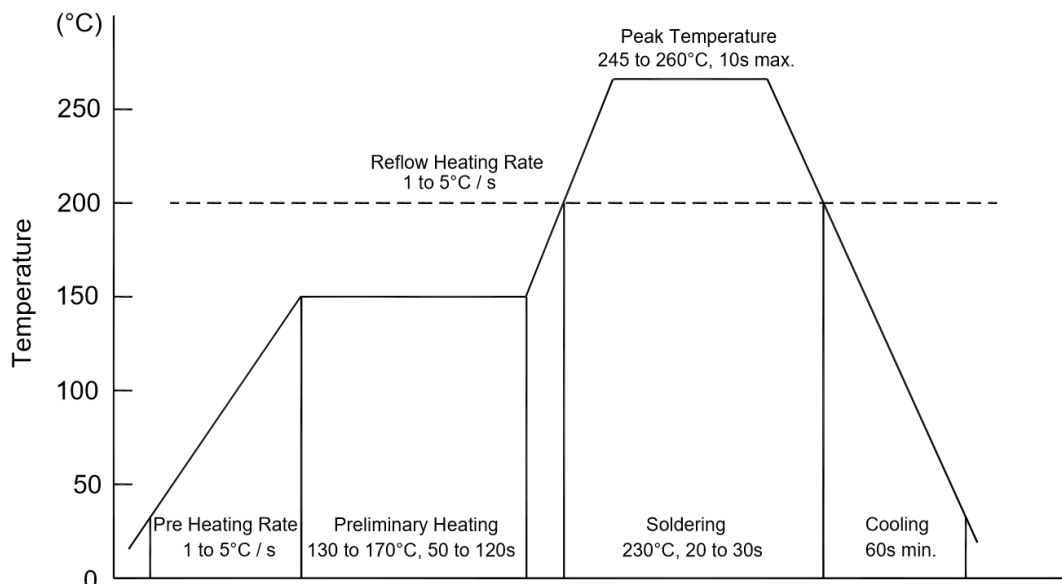

Recommended peak temperature is over 245 °C. If peak temperature is below 245 °C, you may adjust the following parameters:

- Time length of peak temperature (longer)
- Time length of soldering (longer)
- Thickness of solder paste (thicker)

#### ◆ Conditions of hand soldering

- Temperature: 370 °C
- Time: 3s max.
- Times: one time

#### ◆ Storage conditions

- **Temperature**  
5 to 40 °C
- **Humidity**  
30 to 80% RH
- **Recommended period**  
One year after manufacturing

### Package Specifications

- The method of packaging (1,000PCS/Reel&7inches)

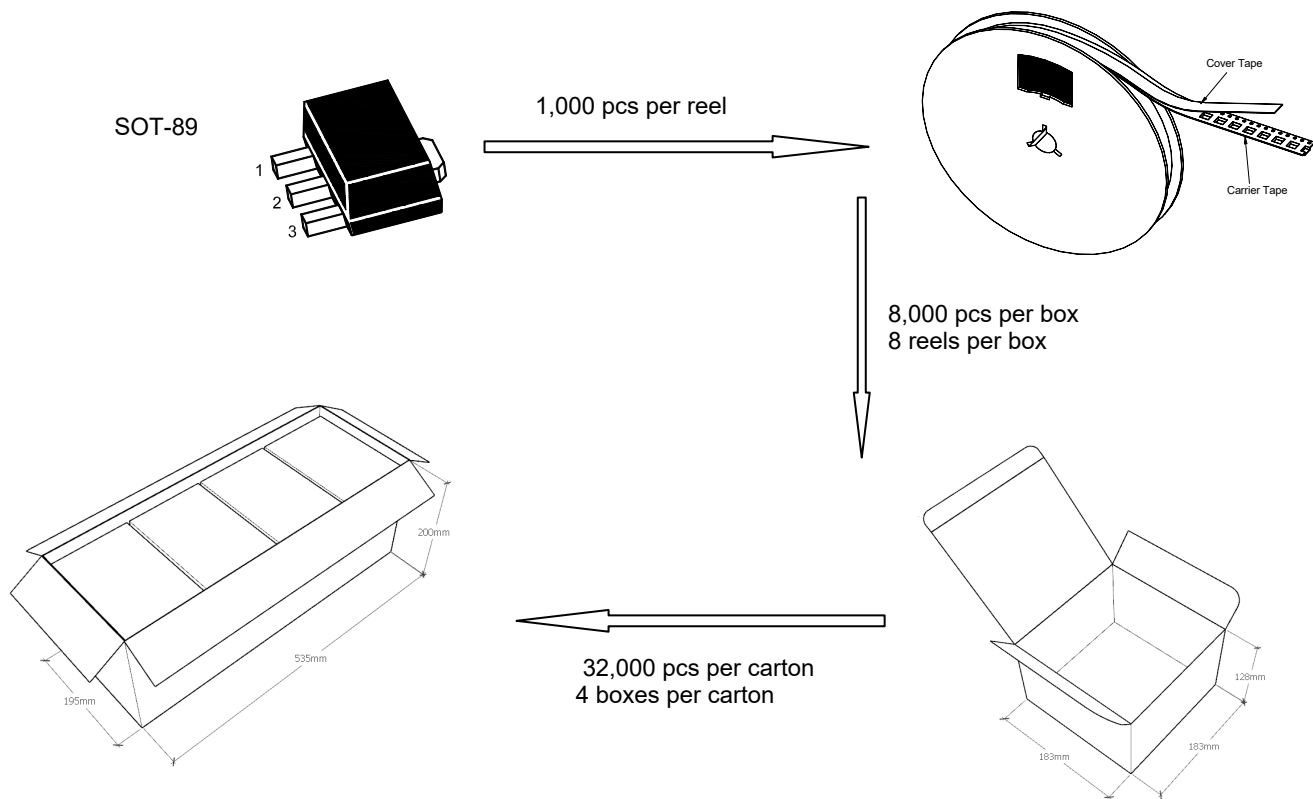

### ◆ Embossed tape and reel data

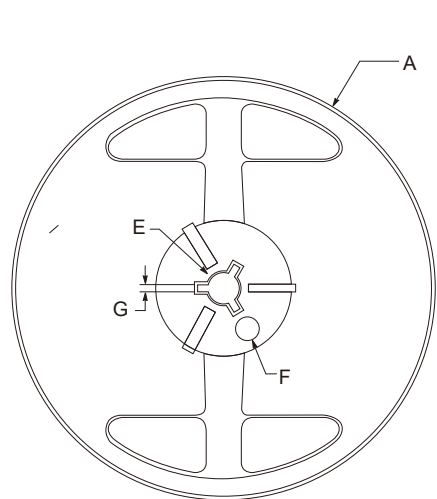

Reel (7")

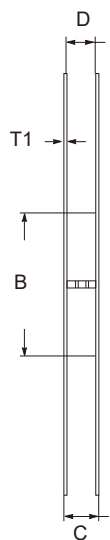

symbol	Value(unit:mm)
A	$\Phi 179 \pm 1$
B	$60.5 \pm 0.2$
C	$15.3 \pm 0.3$
D	$12.5 \sim 13.7$
E	$\Phi 13.5 \pm 0.2$
F	$\Phi 10.0 \pm 0.2$
G	$2.7 \pm 0.2$
T1	$1.0 \pm 0.2$

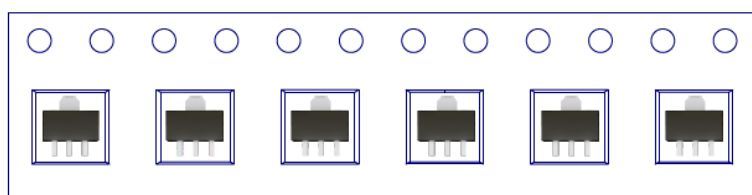

### Package Specifications

- The method of packaging (3,000PCS/Reel&13inches)

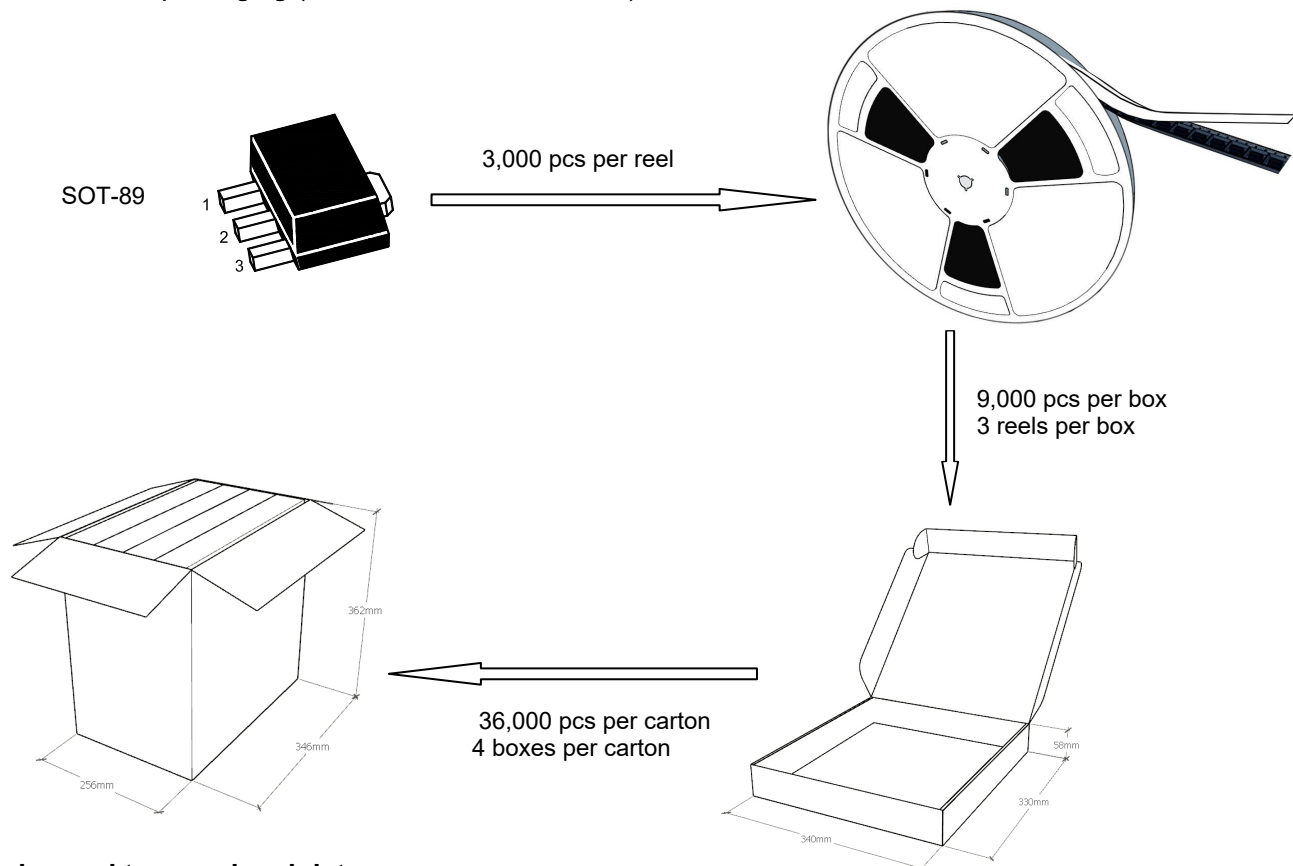

### ◆ Embossed tape and reel data



symbol	Value(unit:mm)
A	$\Phi 330 \pm 1$
B	$12.7 \pm 0.5$
C	$16.5 \pm 0.3$
D	$\Phi 99.5 \pm 0.5$
E	$\Phi 13.6 \pm 0.3$
F	$2.8 \pm 0.3$
T1	$1.9 \pm 0.2$

