

Features

- For Switching and AF Amplifier Applications.

Equivalent Circuit

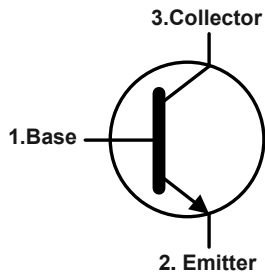

SOT-23

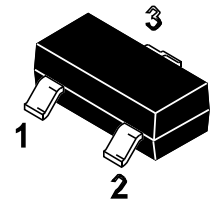

1.Base 2.Emitter 3.Collector

Marking Code : 491.

Absolute Maximum Ratings

Ratings at 25°C ambient temperature unless otherwise specified.

Parameter	Symbol	Value	Unit
Collector Base Voltage	V_{CBO}	80	V
Collector Emitter Voltage	V_{CEO}	35	V
Emitter Base Voltage	V_{EBO}	7	V
Collector Current	I_C	1	A
Maximum Power Dissipation	P_D	250	mW
Junction Temperature	T_J	150	°C
Storage Temperature Range	T_{STG}	-55 to +150	°C



Electrical Characteristics (T_A=25°C)

Parameter	Symbol	Min.	Max.	Unit
DC Current Gain at V _{CE} = 5 V, I _C = 1 mA at V _{CE} = 5 V, I _C = 500 mA at V _{CE} = 5 V, I _C = 1 A at V _{CE} = 5 V, I _C = 2 A	H _{FE}	100 100 80 30	-- 300 -- --	--
Collector Base Cutoff Current at V _{CB} = 60V	I _{CBO}	--	100	nA
Emitter Base Cutoff Current at V _{EB} = 5.6 V	I _{EBO}	--	100	nA
Collector Base Breakdown Voltage at I _C = 100 μA	V _{(BR)CBO}	80	--	V
Collector Emitter Breakdown Voltage at I _C = 10 mA	V _{(BR)CEO}	35	--	V
Emitter Base Breakdown Voltage at I _E = 100 μA	V _{(BR)EBO}	7	--	V
Collector Emitter Saturation Voltage at I _C = 500 mA, I _B = 50 mA at I _C = 1 A, I _B = 100 mA	V _{CE(sat)}	-- --	150 250	mV
Base Emitter Saturation Voltage at I _C = 1 A, I _B = 100 mA	V _{BE(sat)}	--	1.1	V
Base Emitter On Voltage at V _{CE} = 5 V, I _C = 1 A	V _{BE(on)}	--	1	V
Transition Frequency at V _{CE} = 10 V, I _C = 50 mA, f = 100 MHz	F _T	150	--	MHz
Output Capacitance at V _{CB} = 10 V, f = 1 MHz	C _{ob}	--	10	pF



Typical Characteristic Curves

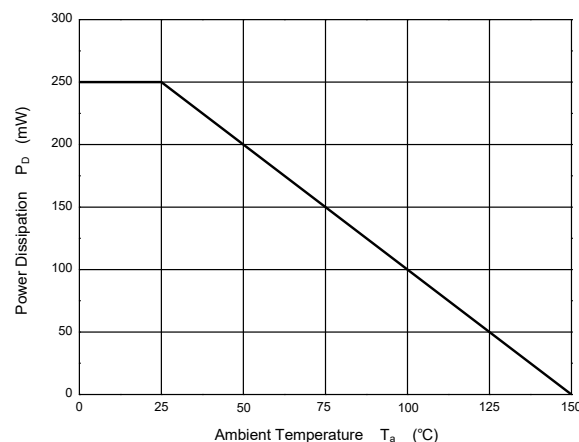
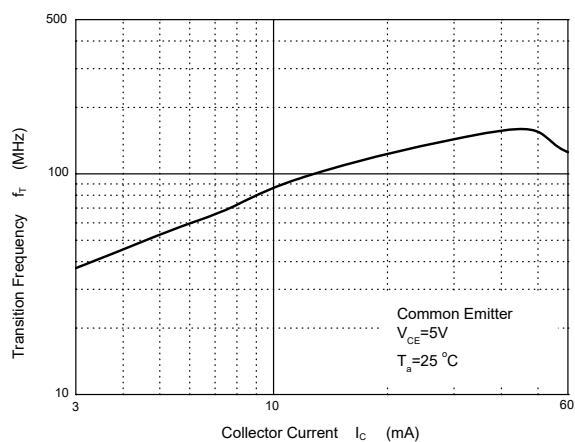
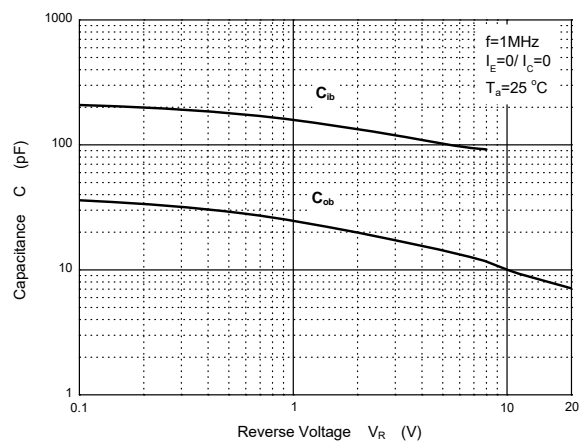
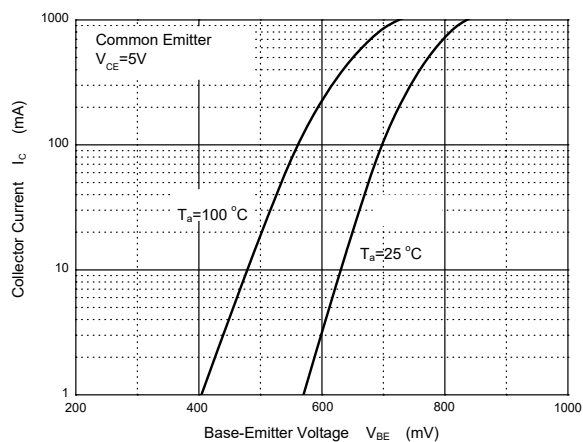
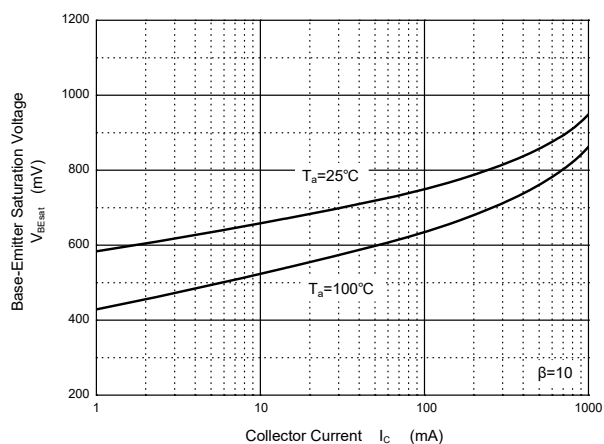
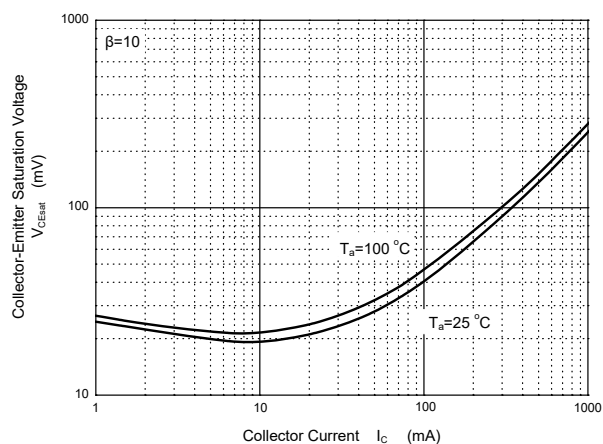
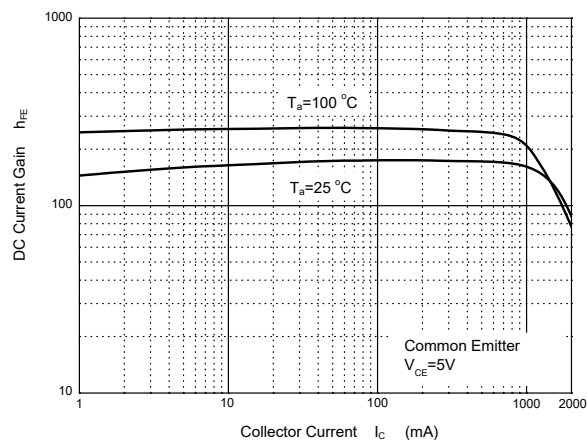
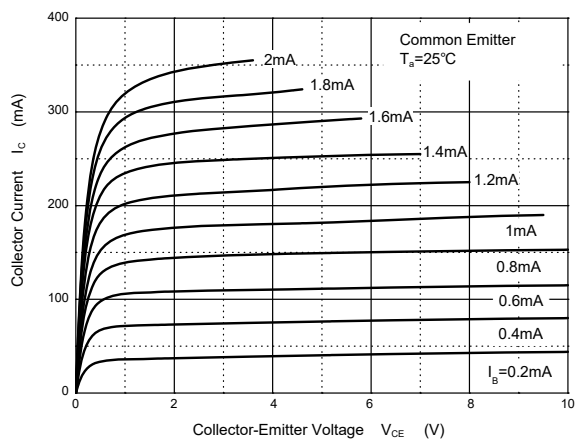

Package Outline

SOT-23

Dimensions in mm

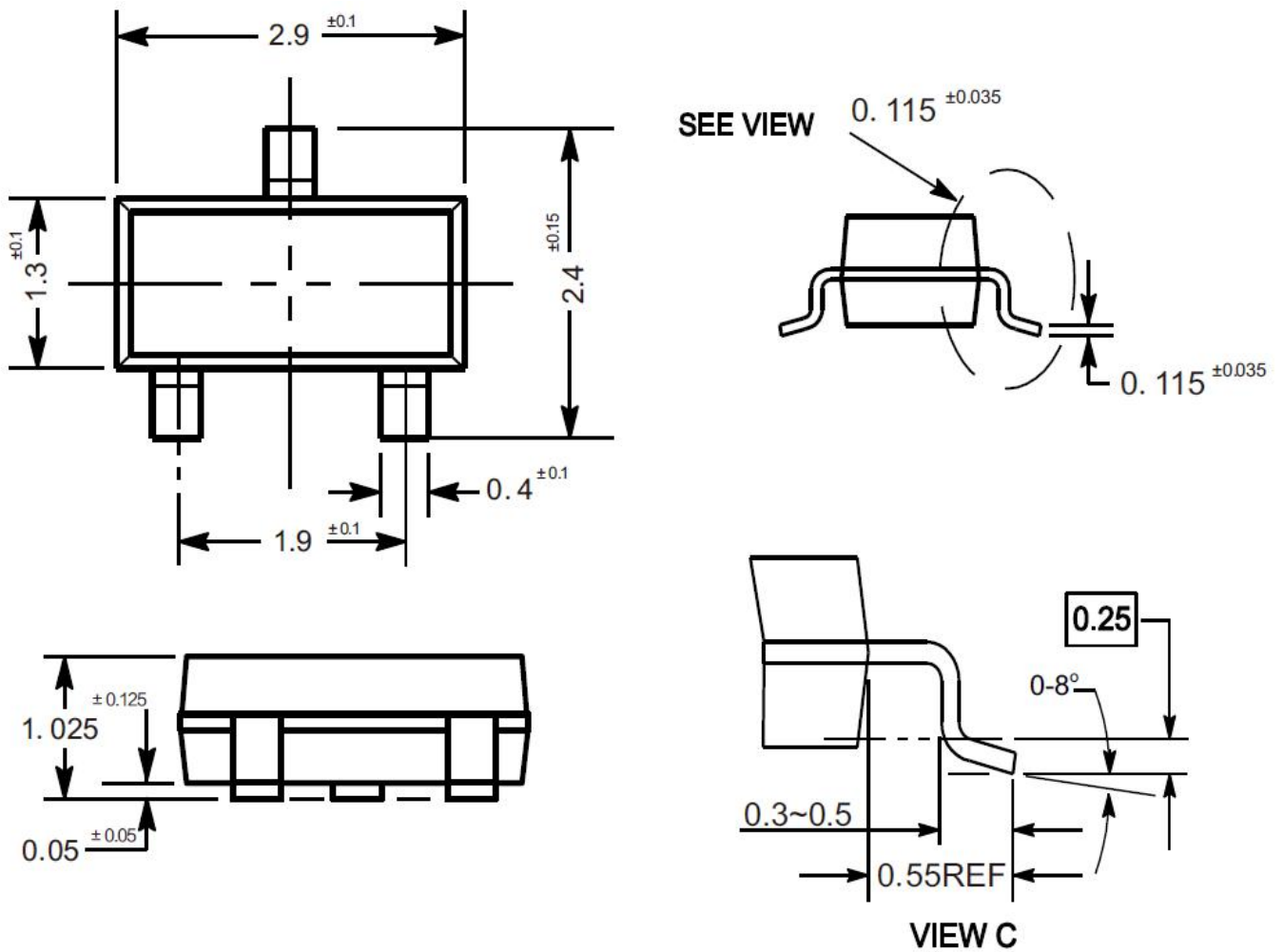

Ordering Information

Device	Package	Shipping
FMMT491-MY	SOT-23	3,000PCS/Reel&7inches

Conditions of Soldering and Storage

◆ Recommended condition of reflow soldering

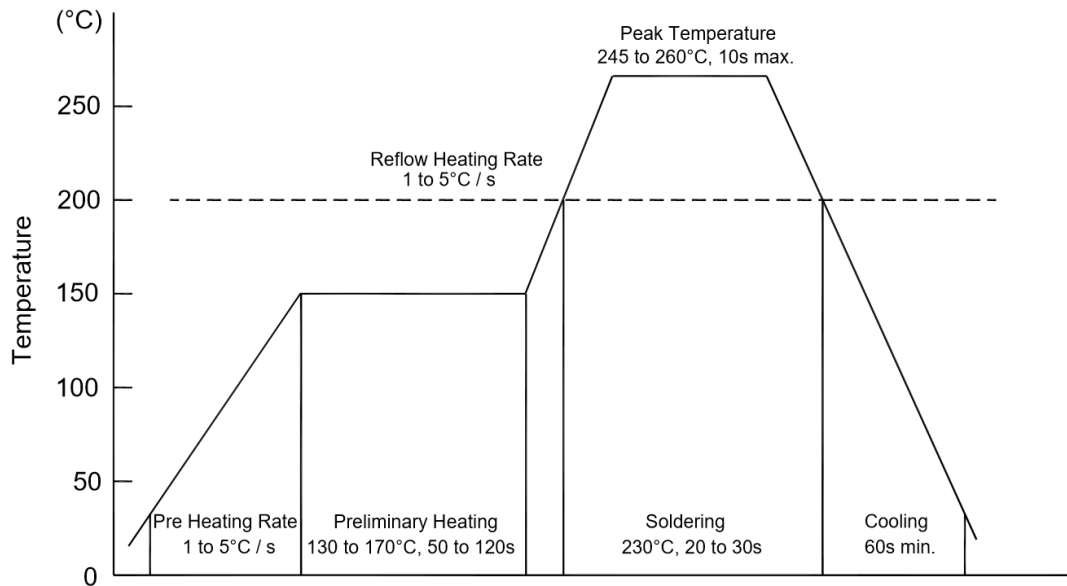

Recommended peak temperature is over 245 °C. If peak temperature is below 245 °C, you may adjust the following parameters:

- Time length of peak temperature (longer)
- Time length of soldering (longer)
- Thickness of solder paste (thicker)

◆ Conditions of hand soldering

- Temperature: 370 °C
- Time: 3s max.
- Times: one time

◆ Storage conditions

- **Temperature**
5 to 40 °C
- **Humidity**
30 to 80% RH
- **Recommended period**
One year after manufacturing

Package Specifications

- The method of packaging

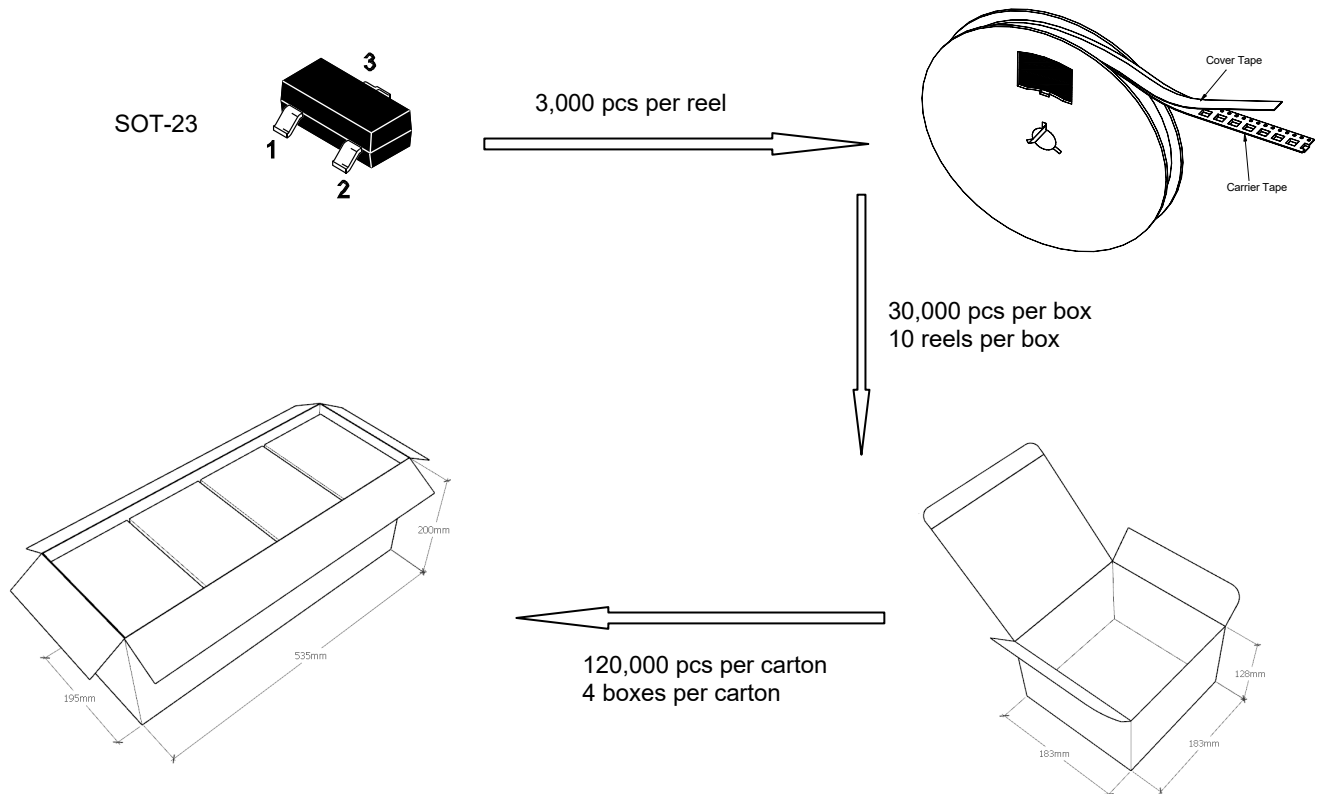

◆ Embossed tape and reel data

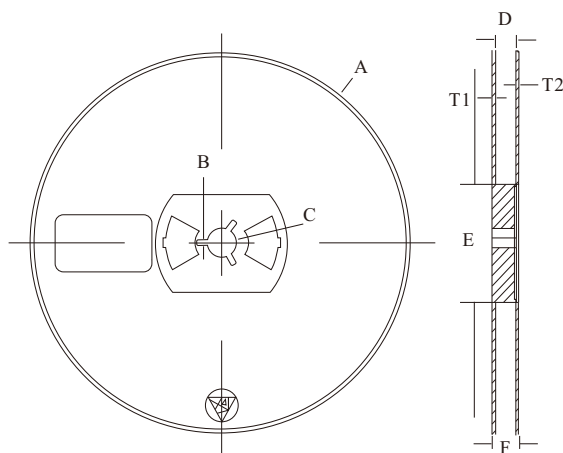

Symbol	Value (unit: mm)
A	Ø 177.8±1
B	2.7±0.2
C	Ø 13.5±0.2
E	Ø 54.5±0.2
F	12.3±0.3
D	9.6+2/-0.3
T1	1.0±0.2
T2	1.2±0.2

Reel (7")

