

Features

- For Switching and AF Amplifier Applications.

Equivalent Circuit

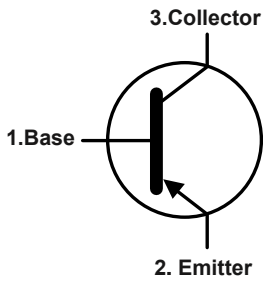

SOT-23

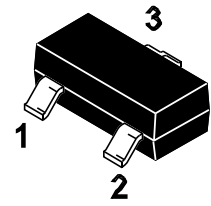

1.Base 2.Emitter 3.Collector

Marking Code : 717

Absolute Maximum Ratings

Ratings at 25°C ambient temperature unless otherwise specified.

Parameter	Symbol	Value	Unit
Collector Base Voltage	$-V_{CB0}$	12	V
Collector Emitter Voltage	$-V_{CEO}$	12	V
Emitter Base Voltage	$-V_{EBO}$	5	V
Collector Current	$-I_c$	2.5	A
Maximum Power Dissipation	P_D	625	mW
Junction Temperature	T_J	150	°C
Storage Temperature Range	T_{STG}	-55 to +150	°C



Electrical Characteristics (T_A=25°C)

Parameter	Symbol	Min.	Max.	Unit
DC Current Gain ^{Note1} at V _{CE} = -2 V, I _C = -10 mA at V _{CE} = -2 V, I _C = -100 mA at V _{CE} = -2 V, I _C = -2.5 A	H _{FE}	300 300 180	-- -- --	--
Collector Base Cutoff Current at V _{CB} = -10 V	-I _{CBO}	--	100	nA
Emitter Base Cutoff Current at V _{EB} = -4 V	-I _{EBO}	--	100	nA
Collector Base Breakdown Voltage at I _C = -100 μA	-V _{(BR)CBO}	12	--	V
Collector Emitter Breakdown Voltage at I _C = -10 mA	-V _{(BR)CEO}	12	--	V
Emitter Base Breakdown Voltage at I _E = -100 μA	-V _{(BR)EBO}	5	--	V
Collector Emitter Saturation Voltage ^{Note1} at I _C = -100 mA, I _B = -10 mA at I _C = -1 A, I _B = -50 mA at I _C = -1.5 A, I _B = -75 mA at I _C = -2.5 A, I _B = -100 mA	-V _{CE(sat)}	-- -- -- --	25 140 170 350	mV
Base Emitter Saturation Voltage ^{Note1} at I _C = -2.5 A, I _B = -50 mA	-V _{BE(sat)}	--	1	V
Base Emitter On Voltage ^{Note1} at V _{CE} = -2 V, I _C = -2.5 A	-V _{BE(on)}	--	1	V
Transition Frequency at V _{CE} = -10 V, I _C = -50 mA	f _T	150	--	MHz
Output Capacitance at V _{CB} = -10 V, f = 1 MHz	C _{ob}	--	30	pF

Note1: Measured under pulsed conditions, Pulse width ≤ 300 us, Duty cycle ≤ 2%.

Typical Characteristic Curves

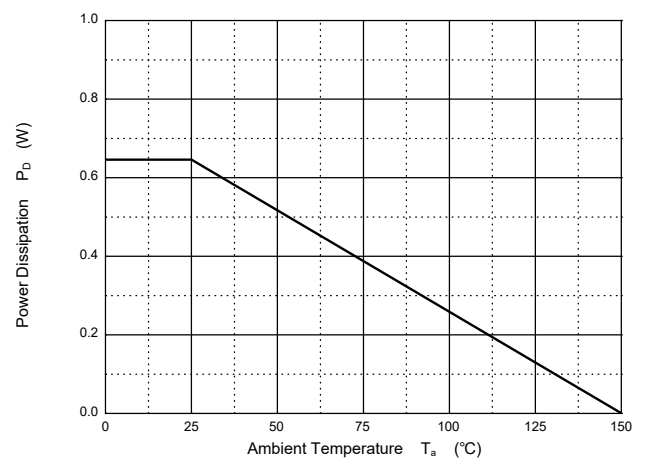
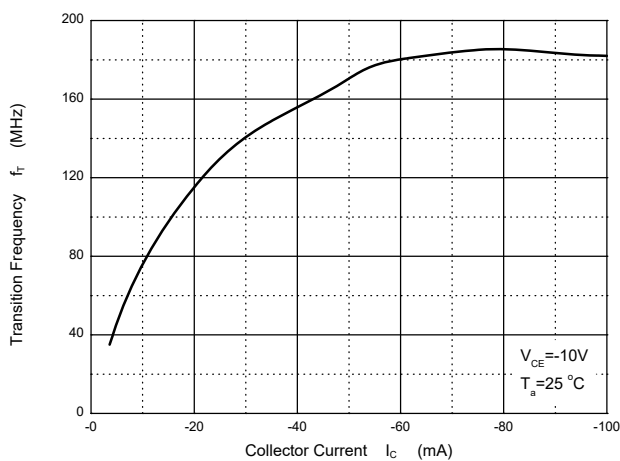
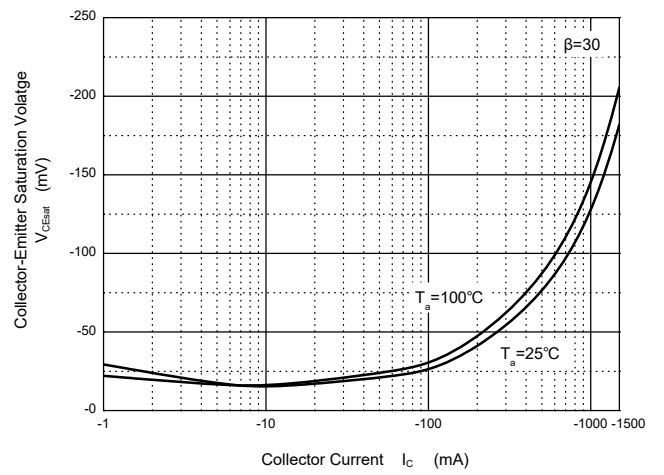
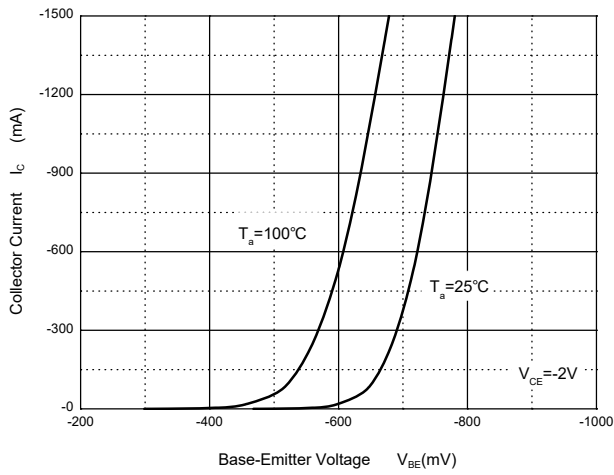
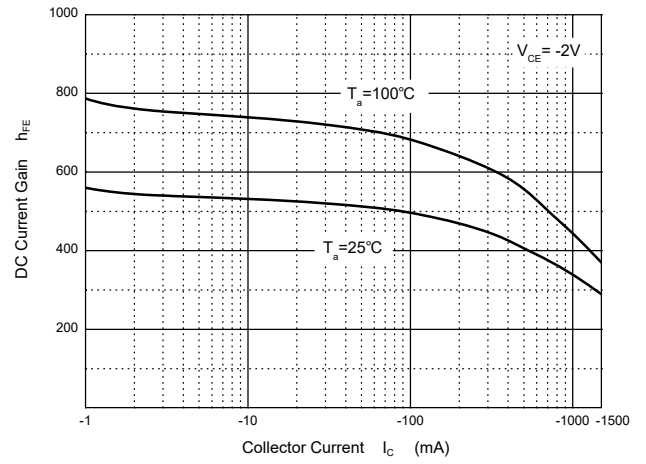
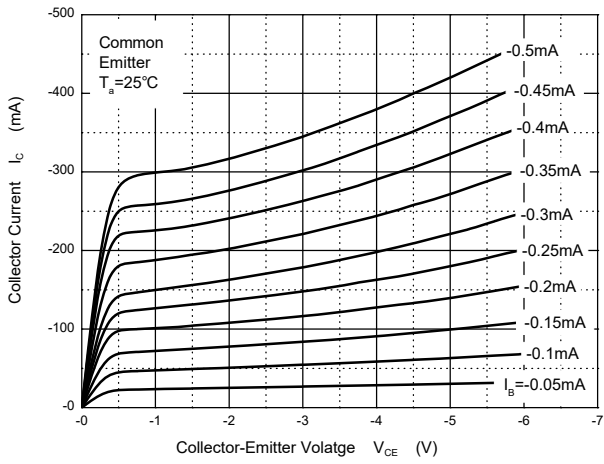

Package Outline

SOT-23

Dimensions in mm

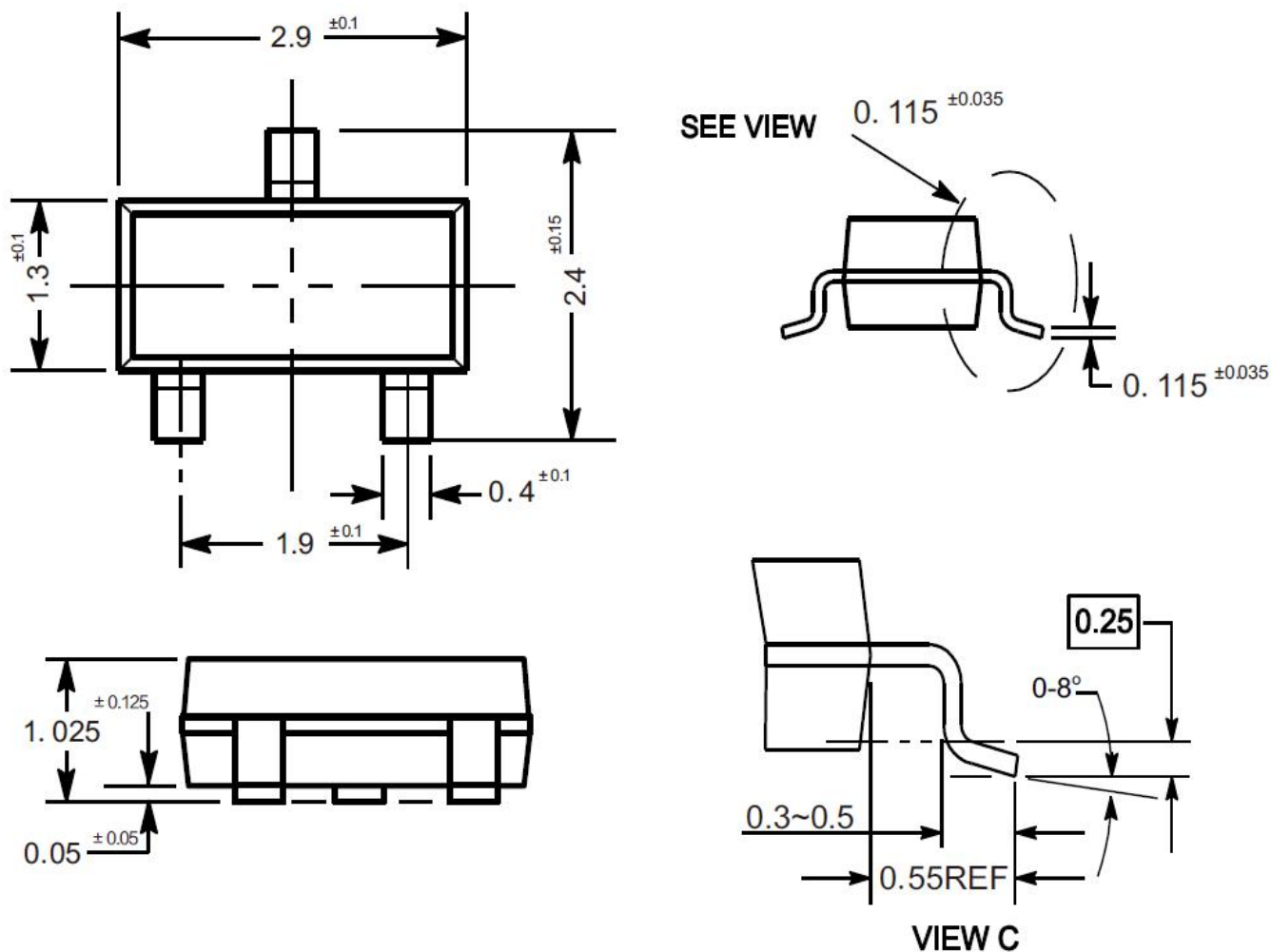

Ordering Information

Device	Package	Shipping
FMMT717	SOT-23	3,000PCS/Reel&7inches

Conditions of Soldering and Storage

◆ Recommended condition of reflow soldering

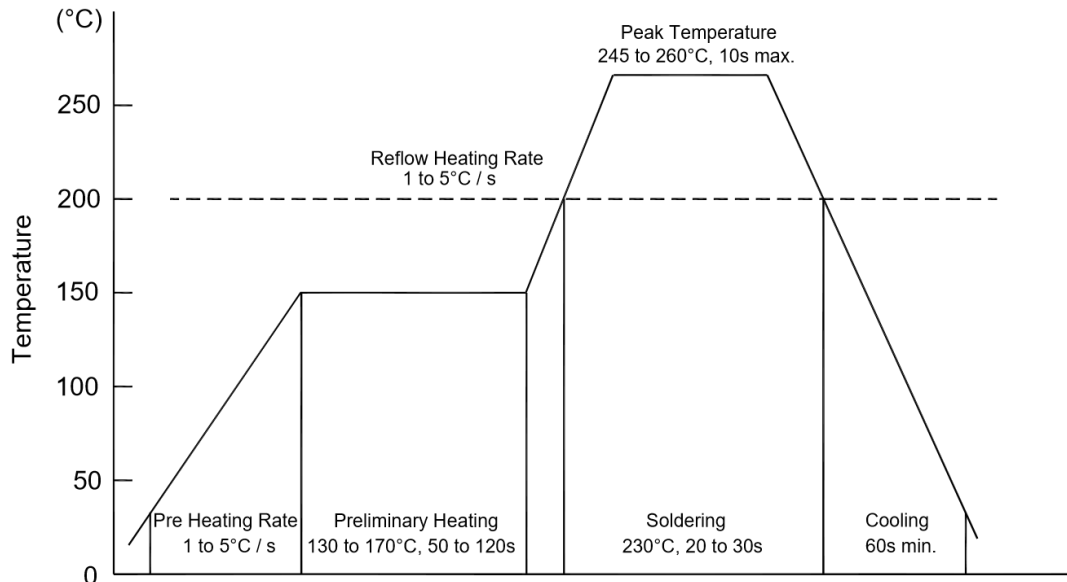

Recommended peak temperature is over 245 °C. If peak temperature is below 245 °C, you may adjust the following parameters:

- Time length of peak temperature (longer)
- Time length of soldering (longer)
- Thickness of solder paste (thicker)

◆ Conditions of hand soldering

- Temperature: 370 °C
- Time: 3s max.
- Times: one time

◆ Storage conditions

- **Temperature**
5 to 40 °C
- **Humidity**
30 to 80% RH
- **Recommended period**
One year after manufacturing

Package Specifications

- The method of packaging

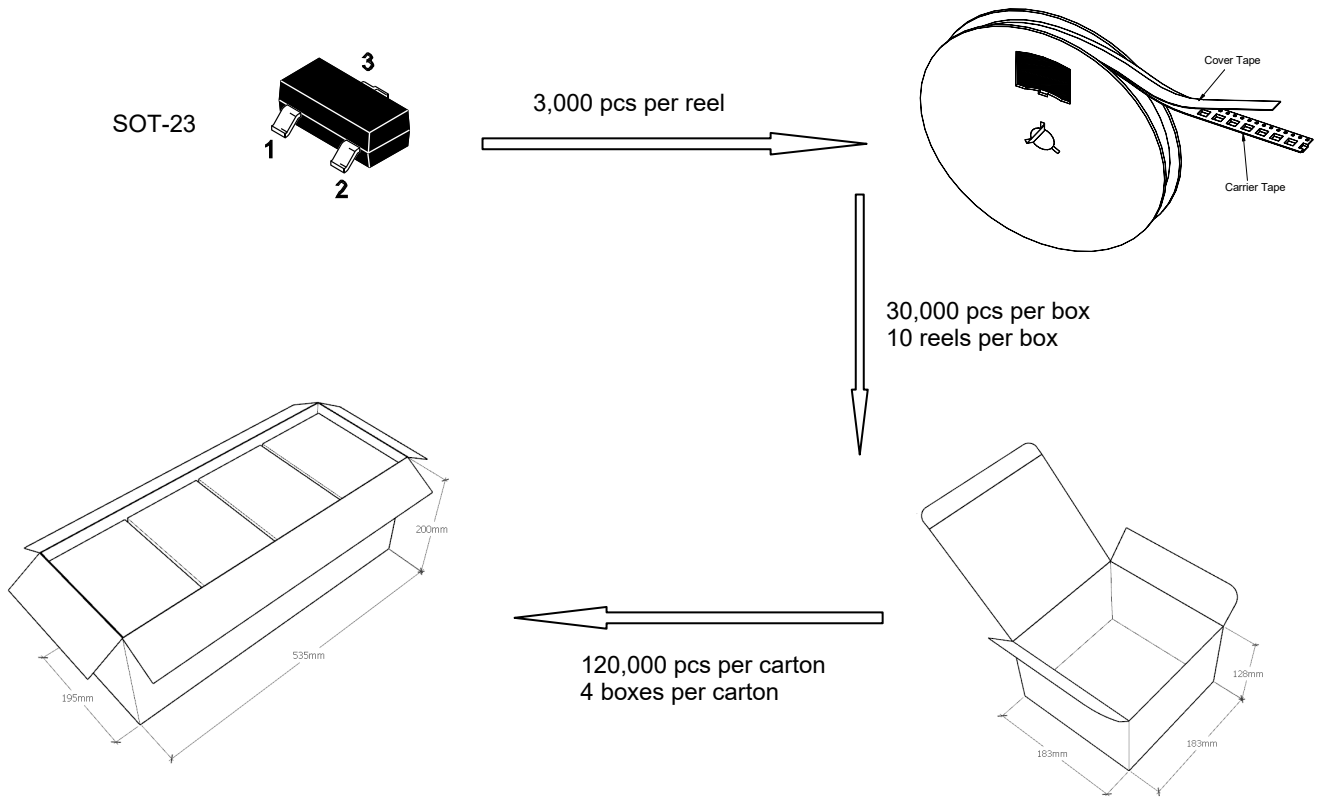

◆ Embossed tape and reel data

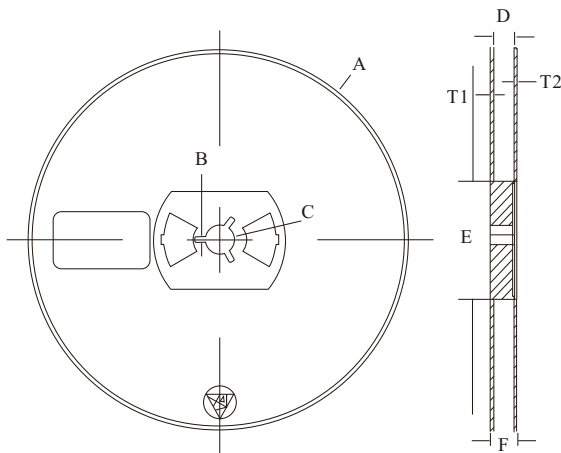

Symbol	Value (unit: mm)
A	Ø 177.8±1
B	2.7±0.2
C	Ø 13.5±0.2
E	Ø 54.5±0.2
F	12.3±0.3
D	9.6+2/-0.3
T1	1.0±0.2
T2	1.2±0.2

Reel (7")

