

Features

- For Switching and AF Amplifier Applications.

Equivalent Circuit

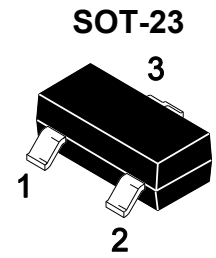
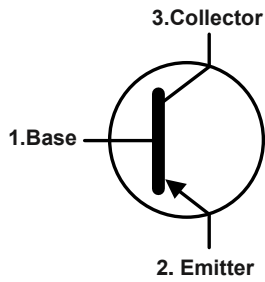

1.Base 2.Emitter 3.Collector

Marking Code : 3E

Absolute Maximum Ratings

Ratings at 25°C ambient temperature unless otherwise specified.

Parameter	Symbol	Value	Unit
Collector Base Voltage	$-V_{CBO}$	40	V
Collector Emitter Voltage	$-V_{CEO}$	40	V
Emitter Base Voltage	$-V_{EBO}$	6	V
Collector Current	$-I_C$	200	mA
Maximum Power Dissipation	P_D	350	mW
Junction Temperature	T_J	150	°C
Storage Temperature Range	T_{STG}	-55 to +150	°C



Electrical Characteristics (T_A=25°C)

Parameter	Symbol	Min.	Max.	Unit
DC Current Gain at V _{CE} = -1 V, I _C = -0.1 mA at V _{CE} = -1 V, I _C = -1 mA at V _{CE} = -1 V, I _C = -10 mA at V _{CE} = -1 V, I _C = -50 mA at V _{CE} = -1 V, I _C = -100 mA	H _{FE}	60 80 100 60 30	-- -- 300 -- --	--
Collector Base Cutoff Current at V _{CB} = -30V	-I _{CBO}	--	50	nA
Emitter Base Cutoff Current at V _{EB} = -6 V	-I _{EBO}	--	50	nA
Collector Base Breakdown Voltage at I _C = -10 μA	-V _{(BR)CBO}	40	--	V
Collector Emitter Breakdown Voltage at I _C = -1 mA	-V _{(BR)CEO}	40	--	V
Emitter Base Breakdown Voltage at I _E = -10 μA	-V _{(BR)EBO}	6	--	V
Collector Emitter Saturation Voltage at I _C = -10 mA, I _B = -1 mA at I _C = -50 mA, I _B = -5 mA	-V _{CE(sat)}	-- --	0.25 0.4	V
Base Emitter Saturation Voltage at I _C = -10 mA, I _B = -1 mA at I _C = -50 mA, I _B = -5 mA	-V _{BE(sat)}	0.65 --	0.85 0.95	V
Transition Frequency at V _{CE} = -20 V, I _C = -10 mA, f = 100 MHz	F _T	250	--	MHz
Output Capacitance at V _{CB} = -5 V, I _E = 0, f = 1 MHz	C _{ob}	--	4.5	pF



Typical Characteristic Curves

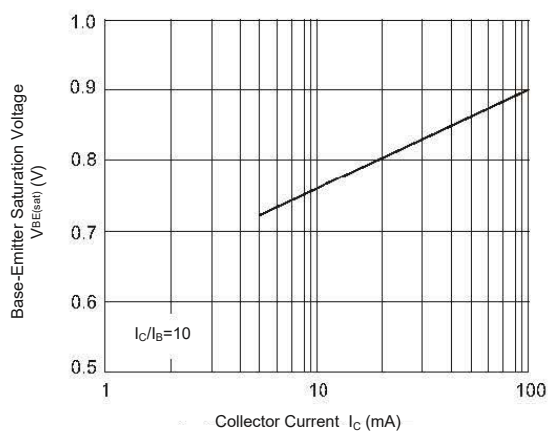
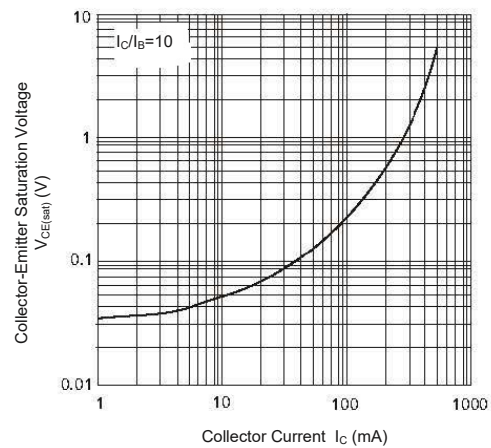
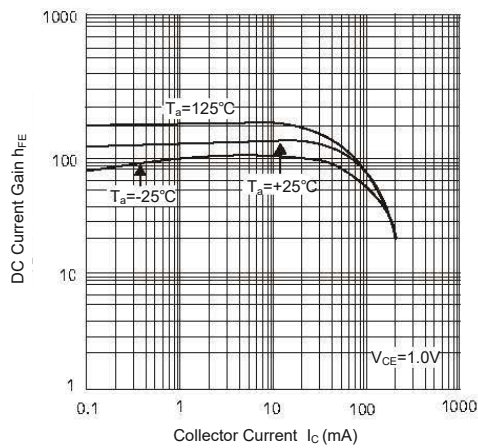
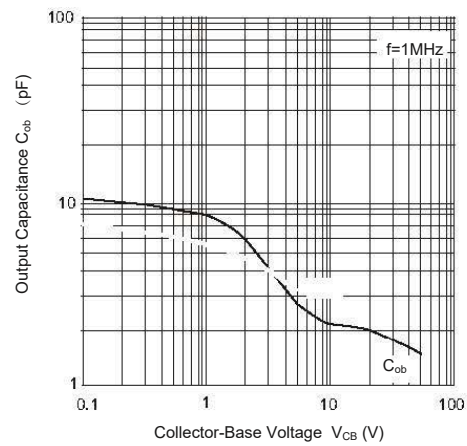
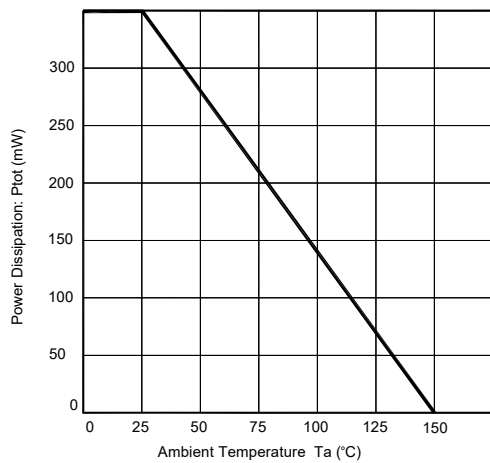

Package Outline

SOT-23

Dimensions in mm

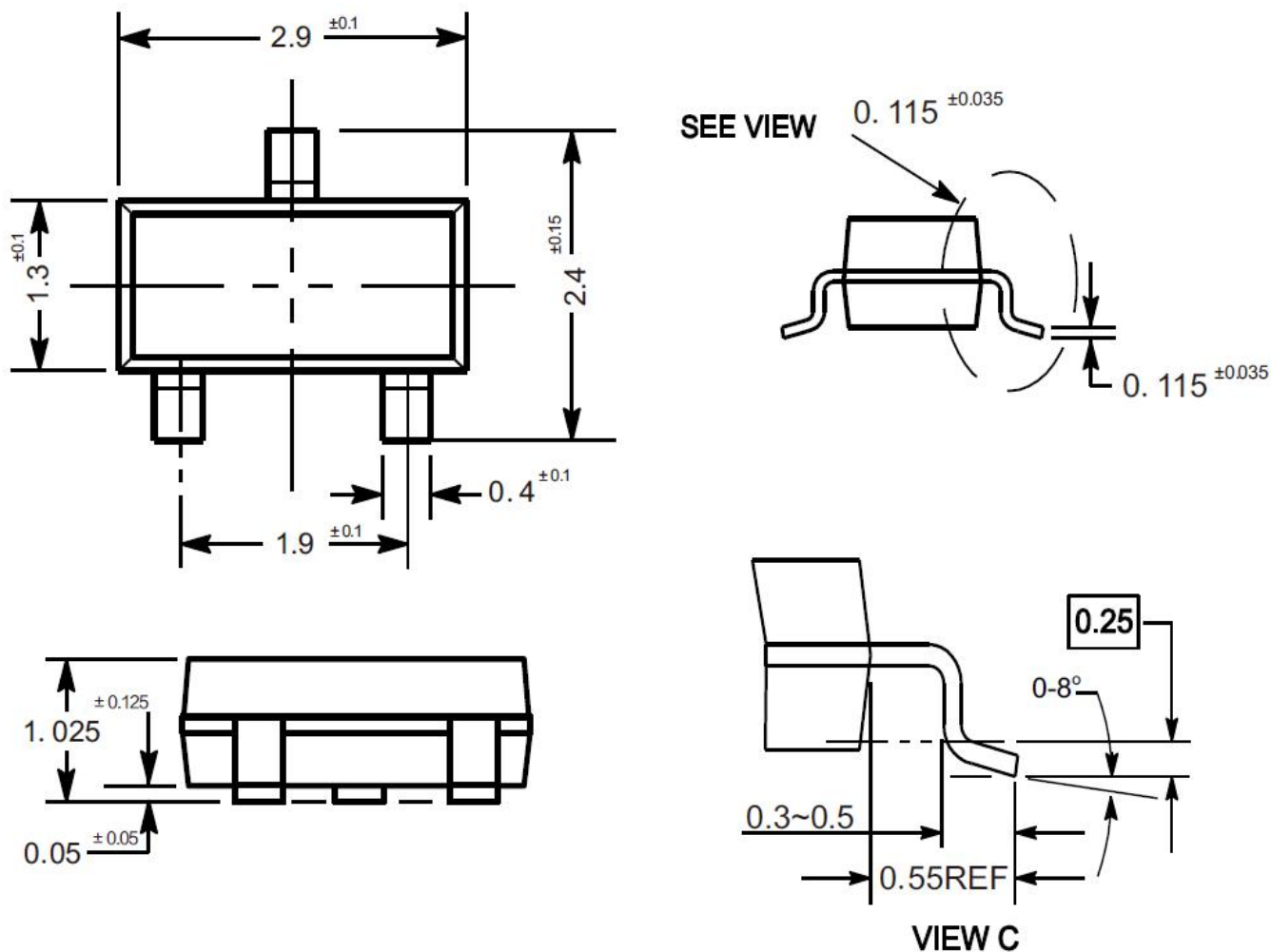

Ordering Information

Device	Package	Shipping
MMBT3906	SOT-23	3,000PCS/Reel&7inches

Conditions of Soldering and Storage

◆ Recommended condition of reflow soldering

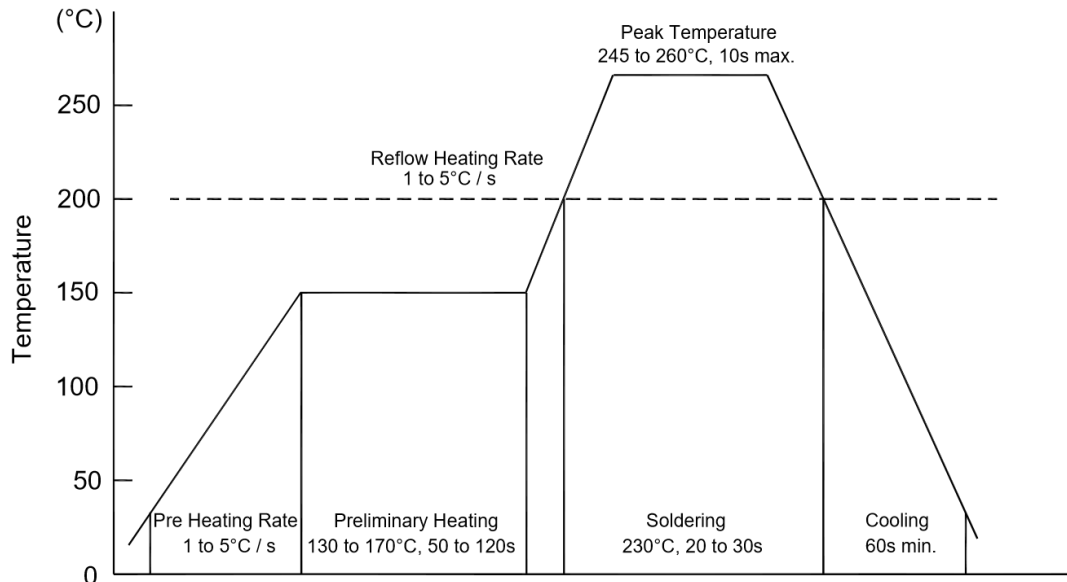

Recommended peak temperature is over 245 °C. If peak temperature is below 245 °C, you may adjust the following parameters:

- Time length of peak temperature (longer)
- Time length of soldering (longer)
- Thickness of solder paste (thicker)

◆ Conditions of hand soldering

- Temperature: 370 °C
- Time: 3s max.
- Times: one time

◆ Storage conditions

- **Temperature**
5 to 40 °C
- **Humidity**
30 to 80% RH
- **Recommended period**
One year after manufacturing

Package Specifications

- The method of packaging

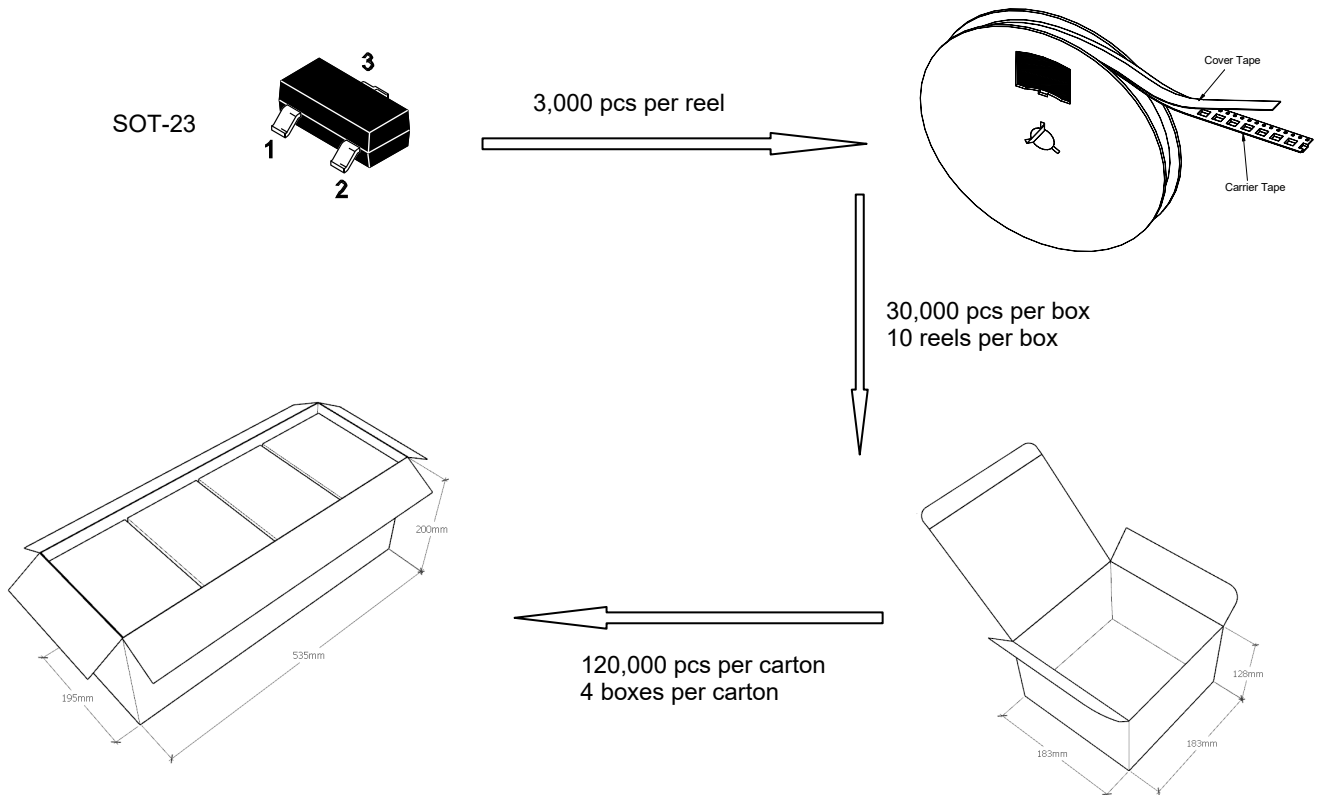

◆ Embossed tape and reel data

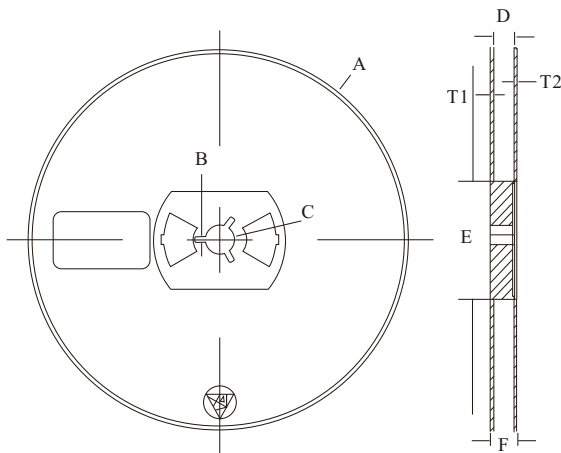

Symbol	Value (unit: mm)
A	$\varnothing 177.8 \pm 1$
B	2.7 ± 0.2
C	$\varnothing 13.5 \pm 0.2$
E	$\varnothing 54.5 \pm 0.2$
F	12.3 ± 0.3
D	$9.6 + 2 / - 0.3$
T1	1.0 ± 0.2
T2	1.2 ± 0.2

Reel (7")

