

### Features

- For Switching and AF Amplifier Applications.

### Equivalent Circuit

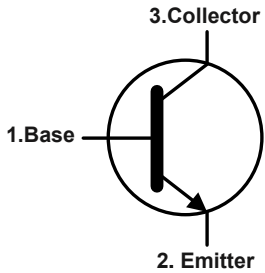

### SOT-23

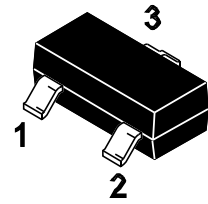

1.Base 2.Emitter 3.Collector

Marking Code :JD

### Absolute Maximum Ratings

Ratings at 25°C ambient temperature unless otherwise specified.

Parameter	Symbol	Value	Unit
Collector Base Voltage	$V_{CBO}$	40	V
Collector Emitter Voltage	$V_{CEO}$	40	V
Emitter Base Voltage	$V_{EBO}$	5	V
Collector Current	$I_C$	1	A
Maximum Power Dissipation	$P_D$	450	mW
Junction Temperature	$T_J$	150	°C
Storage Temperature Range	$T_{STG}$	-55 to +150	°C



### Electrical Characteristics (T<sub>A</sub>=25°C)

Parameter	Symbol	Min.	Max.	Unit
DC Current Gain at V <sub>CE</sub> = 5 V, I <sub>C</sub> = 1 mA at V <sub>CE</sub> = 5 V, I <sub>C</sub> = 500 mA at V <sub>CE</sub> = 5 V, I <sub>C</sub> = 1 A	H <sub>FE</sub>	300 300 200	-- 900 --	--
Collector Base Cutoff Current at V <sub>CB</sub> = 40V	I <sub>CBO</sub>	--	100	nA
Collector Emitter Cutoff Current at V <sub>CE</sub> = 30V	I <sub>CEO</sub>	--	100	nA
Emitter Base Cutoff Current at V <sub>EB</sub> = 5 V	I <sub>EBO</sub>	--	100	nA
Collector Emitter Saturation Voltage at I <sub>C</sub> = 100 mA, I <sub>B</sub> = 1 mA at I <sub>C</sub> = 500 mA, I <sub>B</sub> = 50 mA at I <sub>C</sub> = 1 A, I <sub>B</sub> = 100 mA	V <sub>CE(sat)</sub>	-- -- --	200 250 500	mV
Base Emitter Saturation Voltage at I <sub>C</sub> = 1 A, I <sub>B</sub> = 100 mA	V <sub>BE(sat)</sub>	--	1.2	V
Base Emitter On Voltage at V <sub>CE</sub> = 5 V, I <sub>C</sub> = 1 A	V <sub>BE(on)</sub>	--	1.1	V
Transition Frequency at V <sub>CE</sub> = 10 V, I <sub>C</sub> = 50 mA, f = 100 MHz	F <sub>T</sub>	150	--	MHz
Output Capacitance at V <sub>CB</sub> = 10 V, f = 1 MHz, I <sub>E</sub> = 0	C <sub>ob</sub>	--	10	pF



### Typical Characteristic Curves

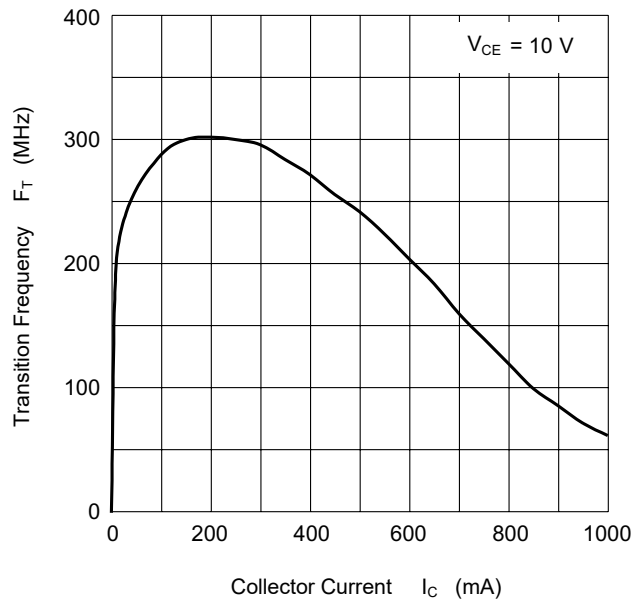
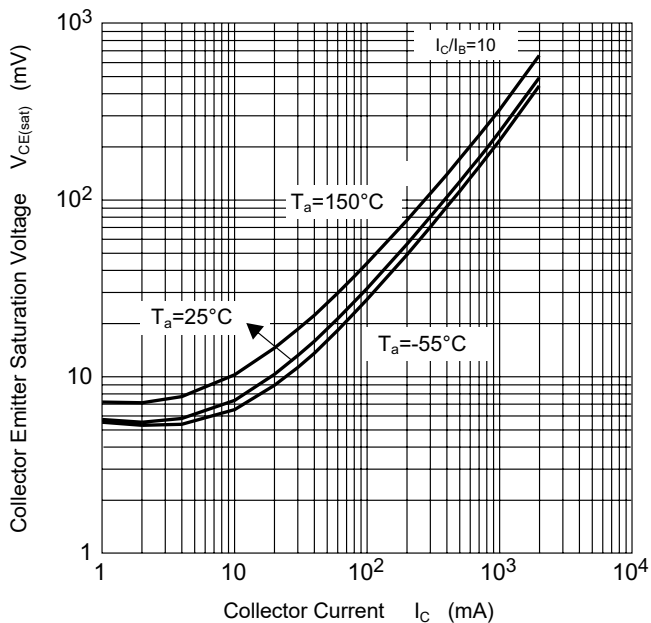
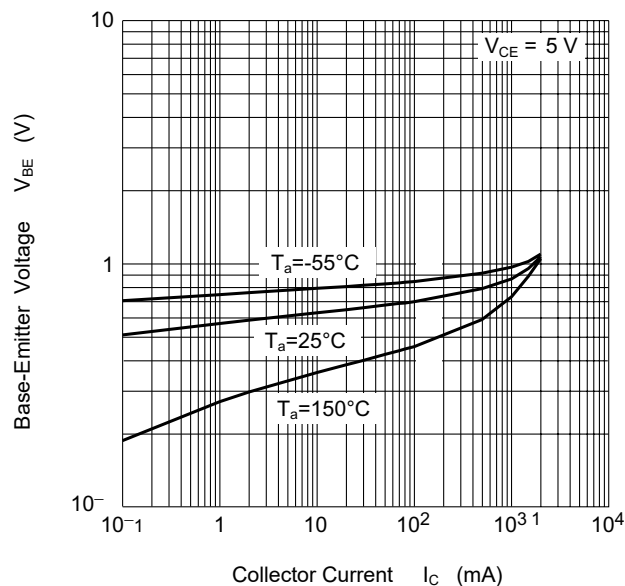
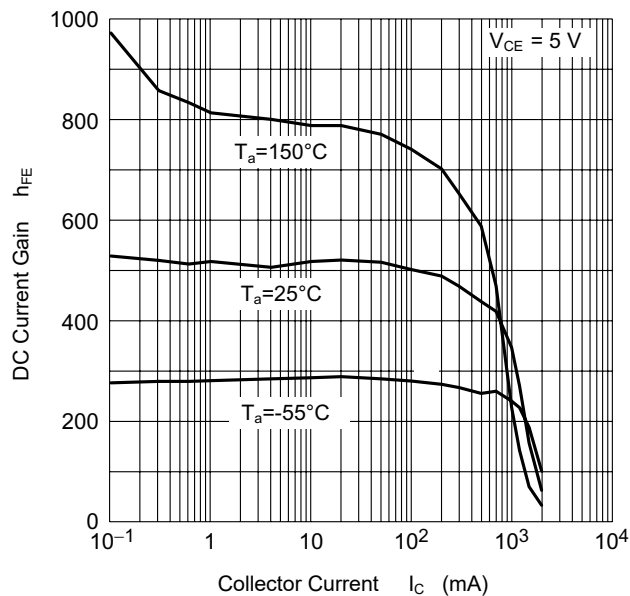

### Package Outline

SOT-23

Dimensions in mm

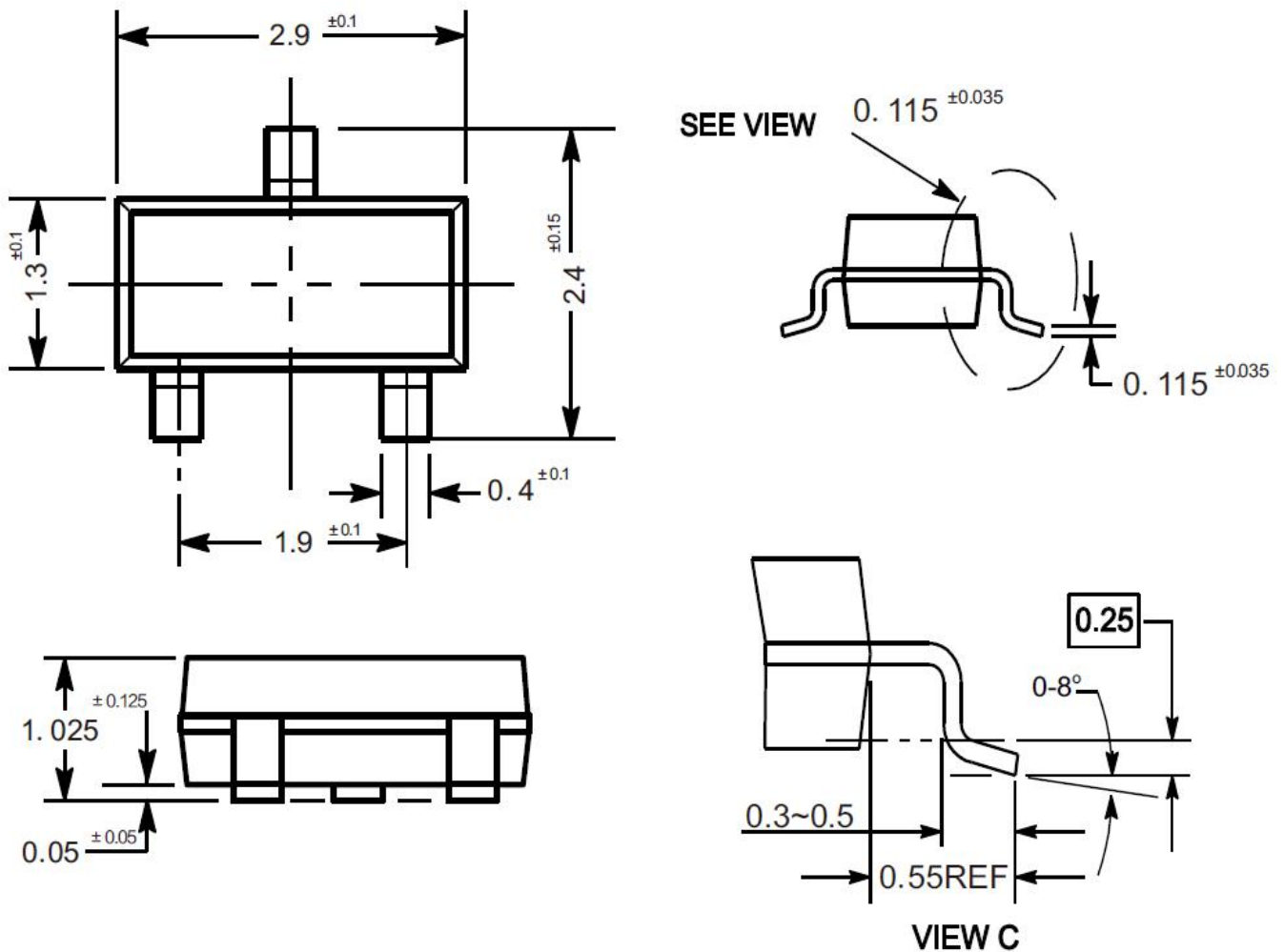

### Ordering Information

Device	Package	Shipping
MMBT4140	SOT-23	3,000PCS/Reel&7inches

### Conditions of Soldering and Storage

#### ◆ Recommended condition of reflow soldering

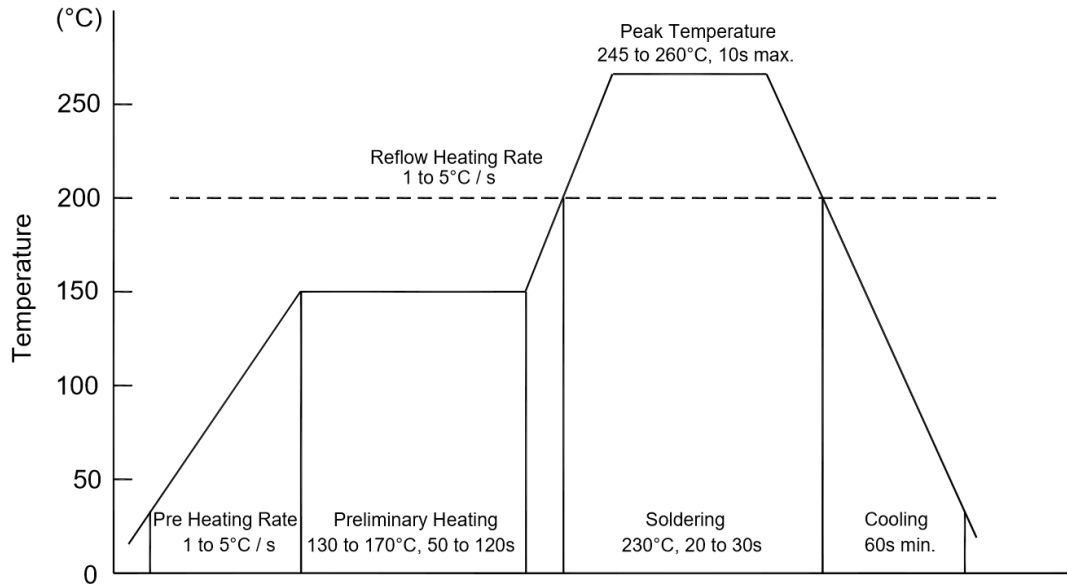

Recommended peak temperature is over 245 °C. If peak temperature is below 245 °C, you may adjust the following parameters:

- Time length of peak temperature (longer)
- Time length of soldering (longer)
- Thickness of solder paste (thicker)

#### ◆ Conditions of hand soldering

- Temperature: 370 °C
- Time: 3s max.
- Times: one time

#### ◆ Storage conditions

- **Temperature**  
5 to 40 °C
- **Humidity**  
30 to 80% RH
- **Recommended period**  
One year after manufacturing

### Package Specifications

- The method of packaging

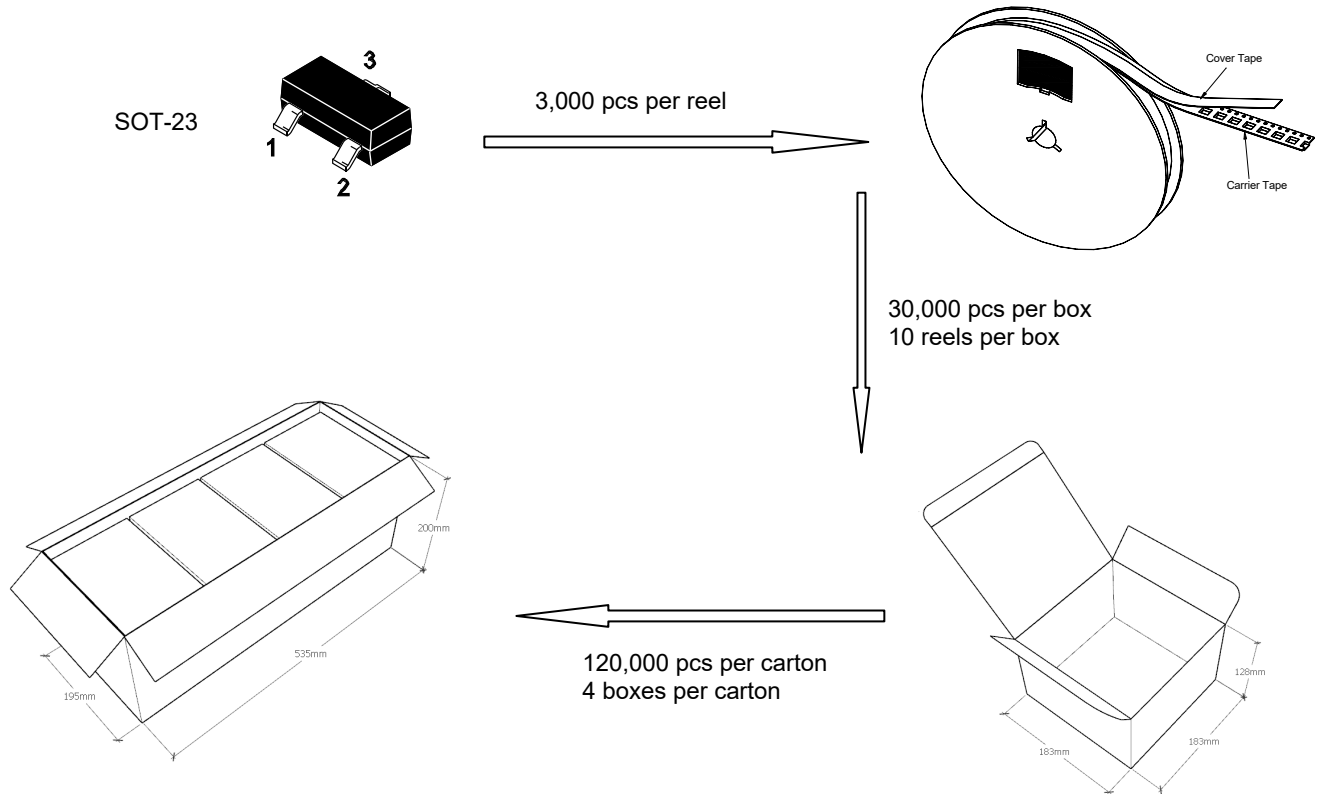

### ◆ Embossed tape and reel data

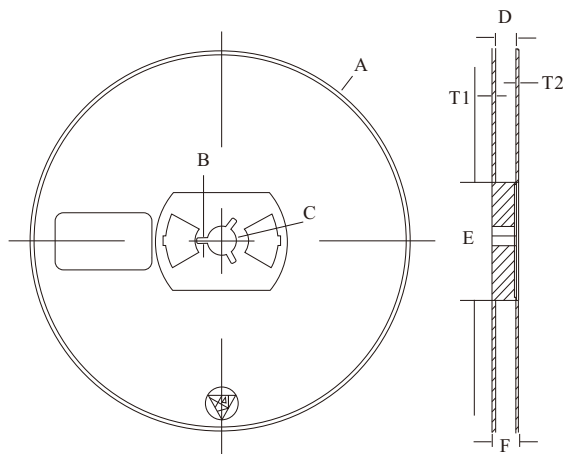

Symbol	Value (unit: mm)
A	$\varnothing 177.8 \pm 1$
B	$2.7 \pm 0.2$
C	$\varnothing 13.5 \pm 0.2$
E	$\varnothing 54.5 \pm 0.2$
F	$12.3 \pm 0.3$
D	$9.6 + 2 / - 0.3$
T1	$1.0 \pm 0.2$
T2	$1.2 \pm 0.2$

Reel (7")

