

Features

- For Switching and AF Amplifier Applications.

Equivalent Circuit

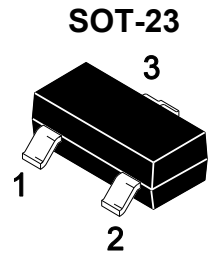
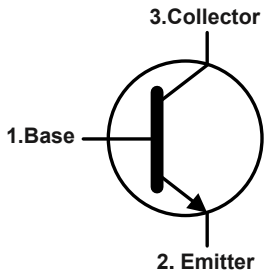

1.Base 2.Emitter 3.Collector

Marking Code : 2X

Absolute Maximum Ratings

Ratings at 25°C ambient temperature unless otherwise specified.

Parameter	Symbol	Value	Unit
Collector Base Voltage	V_{CBO}	60	V
Collector Emitter Voltage	V_{CEO}	40	V
Emitter Base Voltage	V_{EBO}	6	V
Collector Current	I_C	600	mA
Maximum Power Dissipation	P_D	300	mW
Junction Temperature	T_J	150	°C
Storage Temperature Range	T_{STG}	-55 to +150	°C

Thermal Characteristics

Parameter	Symbol	Value	Unit
Thermal Resistance Junction to Ambient	$R_{\theta JA}$	417	°C/W



Electrical Characteristics (T_A=25°C)

Parameter	Symbol	Min.	Max.	Unit
DC Current Gain at V _{CE} = 1 V, I _C = 0.1 mA at V _{CE} = 1 V, I _C = 1 mA at V _{CE} = 1 V, I _C = 10 mA at V _{CE} = 1 V, I _C = 150 mA at V _{CE} = 2 V, I _C = 500 mA	H _{FE}	20 40 80 100 40	-- -- -- 300 --	--
Collector Base Cutoff Current at V _{CB} = 35V	I _{CBO}	--	0.1	μA
Emitter Base Cutoff Current at V _{EB} = 5 V	I _{EBO}	--	0.1	μA
Collector Base Breakdown Voltage at I _C = 0.1 mA	V _{(BR)CBO}	60	--	V
Collector Emitter Breakdown Voltage at I _C = 1 mA	V _{(BR)CEO}	40	--	V
Emitter Base Breakdown Voltage at I _E = 0.1 mA	V _{(BR)EBO}	6	--	V
Collector Emitter Saturation Voltage at I _C = 10 mA, I _B = 1 mA at I _C = 50 mA, I _B = 5 mA	V _{CE(sat)}	-- --	0.4 0.75	V
Base Emitter Saturation Voltage at I _C = 150 mA, I _B = 15 mA at I _C = 500 mA, I _B = 50 mA	V _{BE(sat)}	0.75 --	0.95 1.2	V
Transition Frequency at V _{CE} = 10 V, I _C = 20 mA, f = 100 MHz	F _T	250	--	MHz
Output Capacitance at V _{CB} = 5 V, f = 1 MHz	C _{ob}	--	6.5	pF



Typical Characteristic Curves

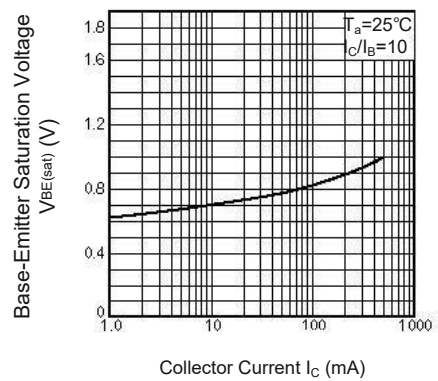
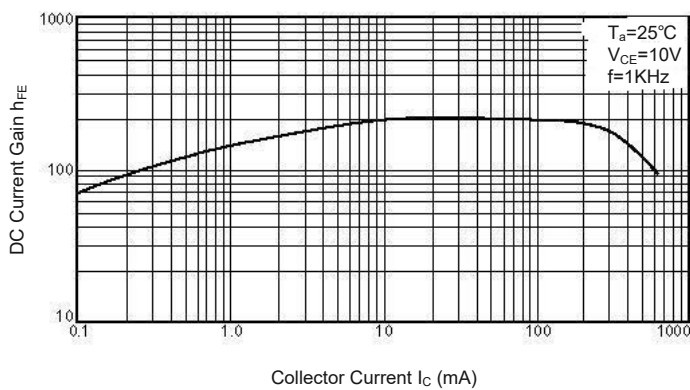
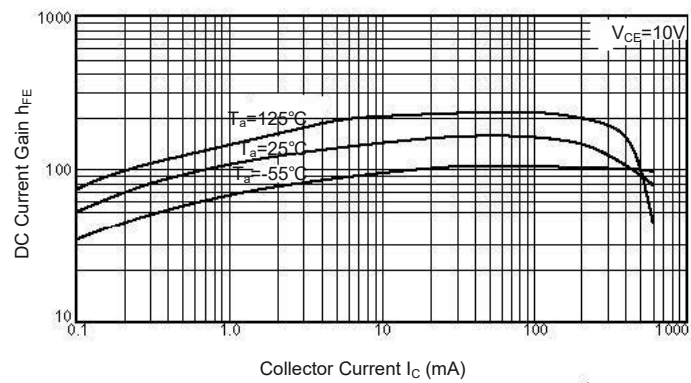
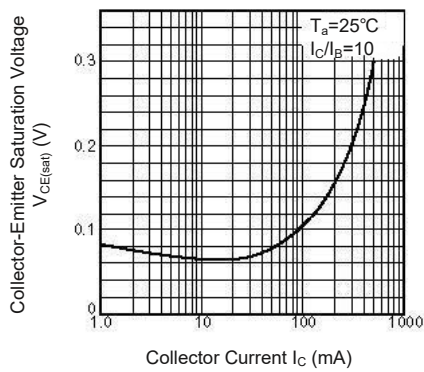
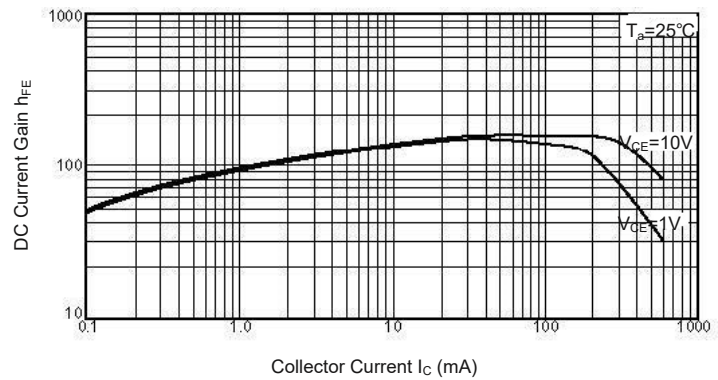
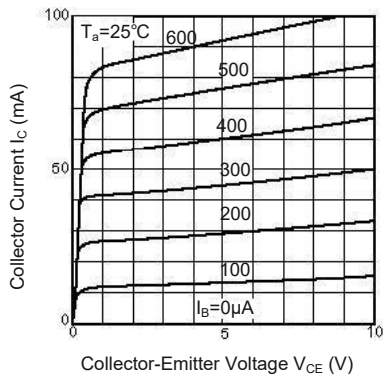

Package Outline

SOT-23

Dimensions in mm

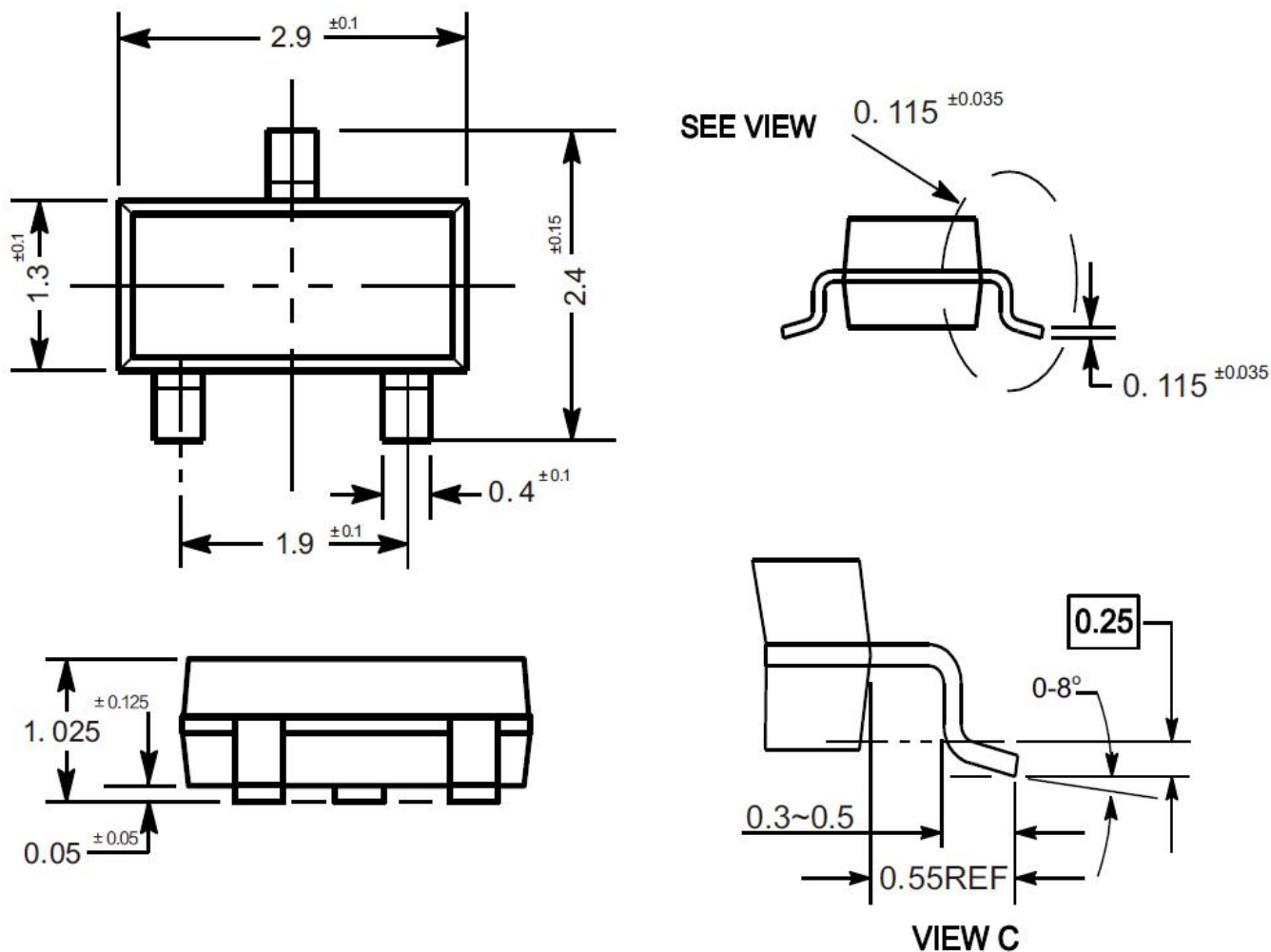

Ordering Information

Device	Package	Shipping
MMBT4401	SOT-23	3,000PCS/Reel&7inches

Conditions of Soldering and Storage

◆ Recommended condition of reflow soldering



Recommended peak temperature is over 245 °C. If peak temperature is below 245 °C, you may adjust the following parameters:

- Time length of peak temperature (longer)
- Time length of soldering (longer)
- Thickness of solder paste (thicker)

◆ Conditions of hand soldering

- Temperature: 370 °C
- Time: 3s max.
- Times: one time

◆ Storage conditions

- **Temperature**
5 to 40 °C
- **Humidity**
30 to 80% RH
- **Recommended period**
One year after manufacturing

Package Specifications

- The method of packaging

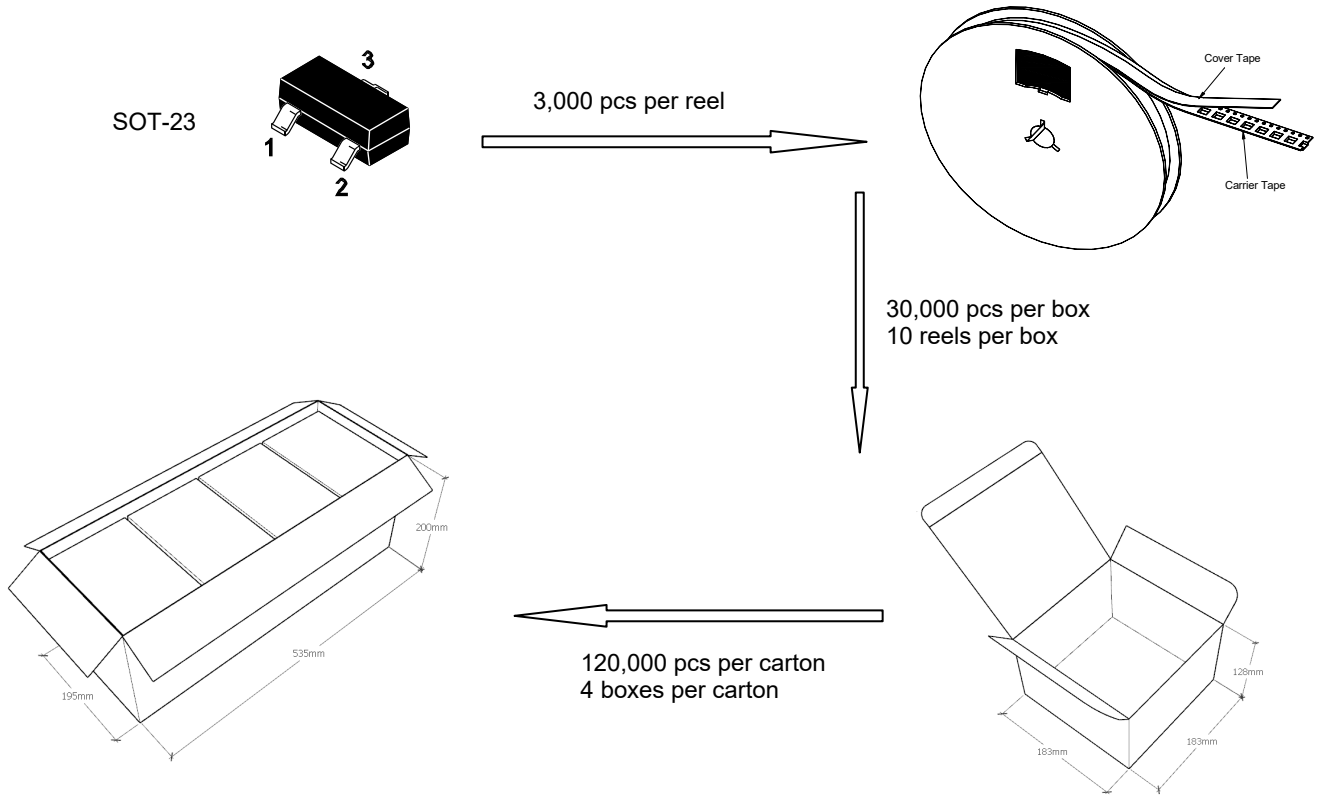

◆ Embossed tape and reel data

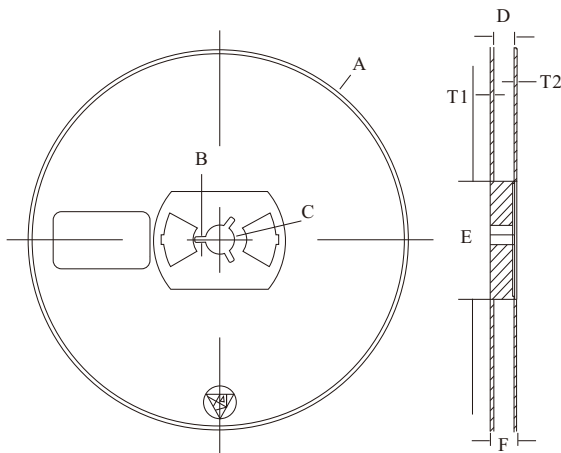

Symbol	Value (unit: mm)
A	Ø 177.8±1
B	2.7±0.2
C	Ø 13.5±0.2
E	Ø 54.5±0.2
F	12.3±0.3
D	9.6+2/-0.3
T1	1.0±0.2
T2	1.2±0.2

Reel (7")

