

### Features

- For Switching and AF Amplifier Applications.

SOT-23

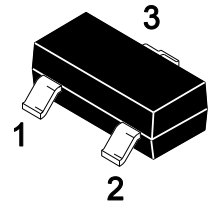

### Equivalent Circuit

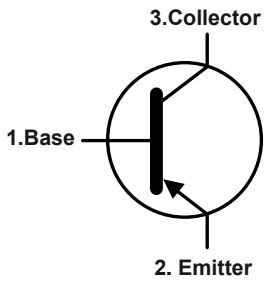

1.Base 2.Emitter 3.Collector

### Marking Code :

MMBT8550C-1.5A : X2

MMBT8550D-1.5A : Y2

### Absolute Maximum Ratings

Ratings at 25°C ambient temperature unless otherwise specified.

Parameter	Symbol	Value	Unit
Collector Base Voltage	$-V_{CBO}$	40	V
Collector Emitter Voltage	$-V_{CEO}$	25	V
Emitter Base Voltage	$-V_{EBO}$	6	V
Collector Current	$-I_C$	1.5	A
Maximum Power Dissipation	$P_D$	625	mW
Junction Temperature	$T_J$	150	°C
Storage Temperature Range	$T_{STG}$	-55 to +150	°C



### Electrical Characteristics (T<sub>A</sub>=25°C)

Parameter	Symbol	Min.	Max.	Unit
DC Current Gain at V <sub>CE</sub> = -1 V, I <sub>C</sub> = -100 mA	H <sub>FE</sub>	100	250	--
Gain Group		160	400	
at V <sub>CE</sub> = -1 V, I <sub>C</sub> = -800 mA		40	--	
Collector Base Cutoff Current at V <sub>CB</sub> = -35 V	-I <sub>CB0</sub>	--	100	nA
Base Base Cutoff Current at V <sub>EB</sub> = -6 V	-I <sub>EBO</sub>	--	100	nA
Collector Base Breakdown Voltage at I <sub>C</sub> = -100 μA	-V <sub>(BR)CBO</sub>	40	--	V
Collector Emitter Breakdown Voltage at I <sub>C</sub> = -2 mA	-V <sub>(BR)CEO</sub>	25	--	V
Emitter Base Breakdown Voltage at I <sub>E</sub> = -100 μA	-V <sub>(BR)EBO</sub>	6	--	V
Collector Emitter Saturation Voltage at I <sub>C</sub> = -800 mA, I <sub>B</sub> = -80 mA	-V <sub>CE(sat)</sub>	--	0.5	V
Base Emitter Saturation Voltage at I <sub>C</sub> = -800 mA, I <sub>B</sub> = -80 mA	-V <sub>BE(sat)</sub>	--	1.2	V
Base Emitter On Voltage at V <sub>CE</sub> = -1 V, I <sub>C</sub> = -10 mA	-V <sub>BE(on)</sub>	--	1	V
Transition Frequency at V <sub>CE</sub> = -10 V, I <sub>C</sub> = -50 mA	F <sub>T</sub>	120	--	MHz



### Typical Characteristic Curves

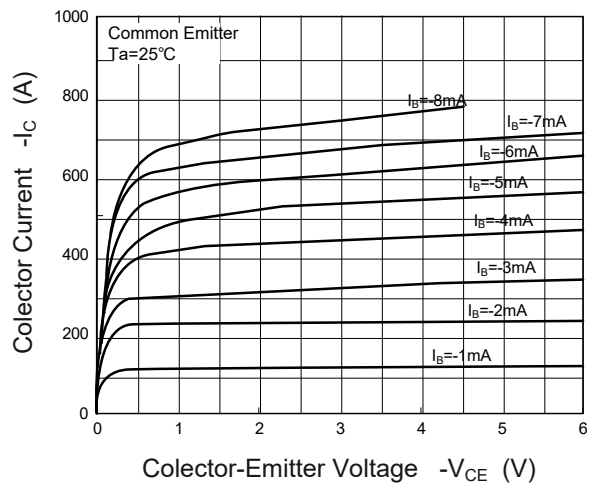
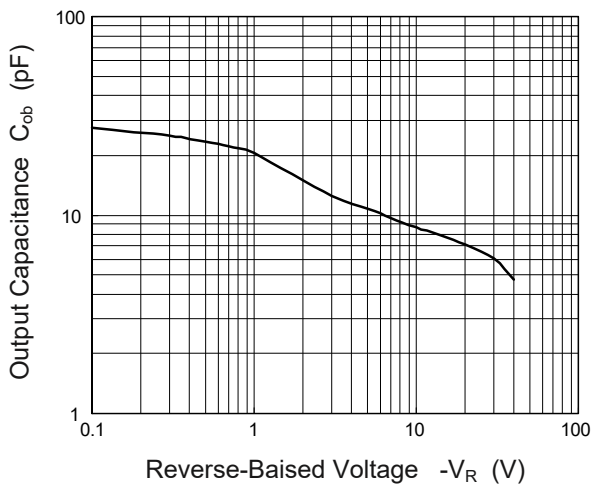
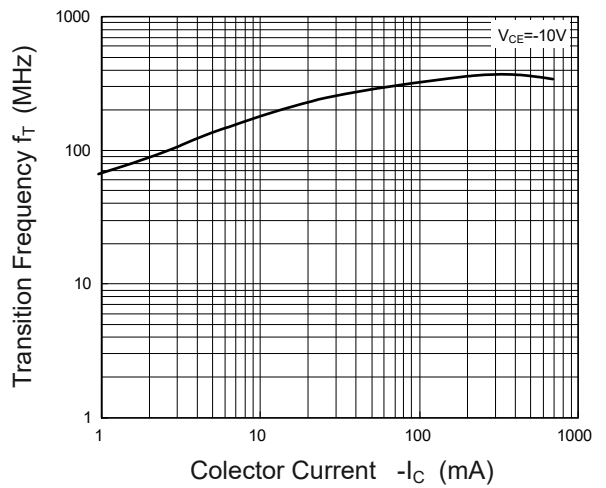
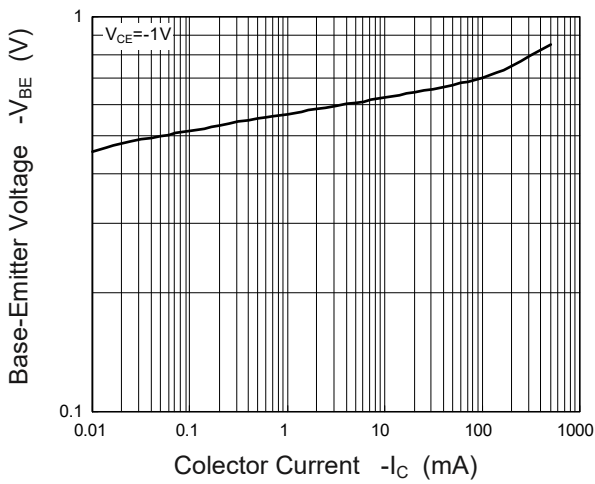
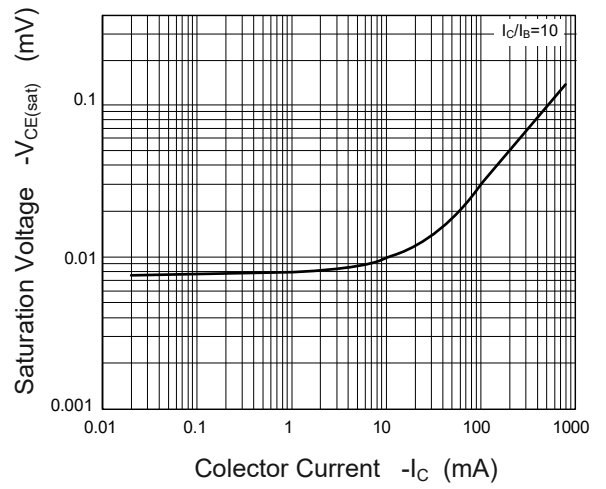
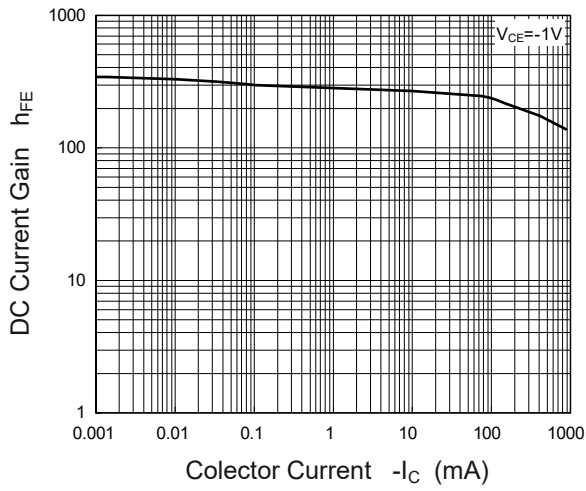

### Package Outline

SOT-23

Dimensions in mm

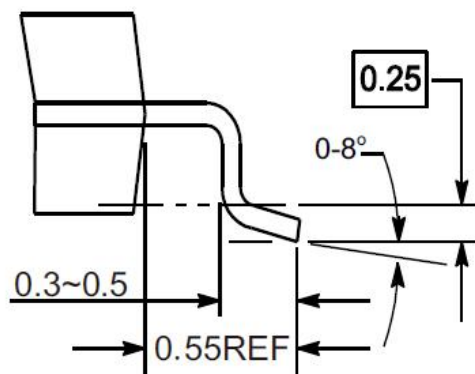
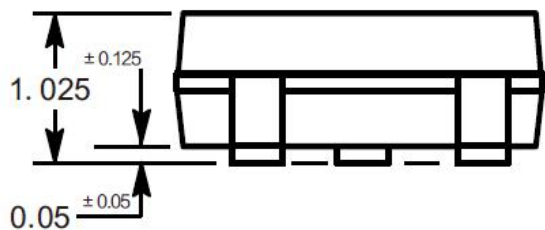
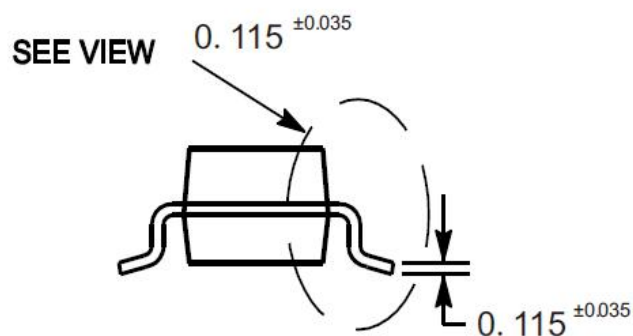
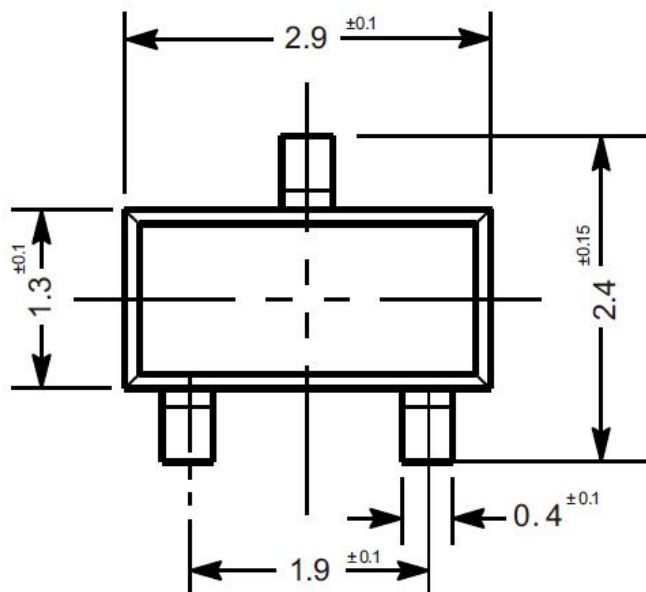

VIEW C

### Ordering Information

Device	Package	Shipping
MMBT8550-1.5A	SOT-23	3,000PCS/Reel&7inches

### Conditions of Soldering and Storage

#### ◆ Recommended condition of reflow soldering



Recommended peak temperature is over 245 °C. If peak temperature is below 245 °C, you may adjust the following parameters:

- Time length of peak temperature (longer)
- Time length of soldering (longer)
- Thickness of solder paste (thicker)

#### ◆ Conditions of hand soldering

- Temperature: 370 °C
- Time: 3s max.
- Times: one time

#### ◆ Storage conditions

- **Temperature**  
5 to 40 °C
- **Humidity**  
30 to 80% RH
- **Recommended period**  
One year after manufacturing

### Package Specifications

- The method of packaging

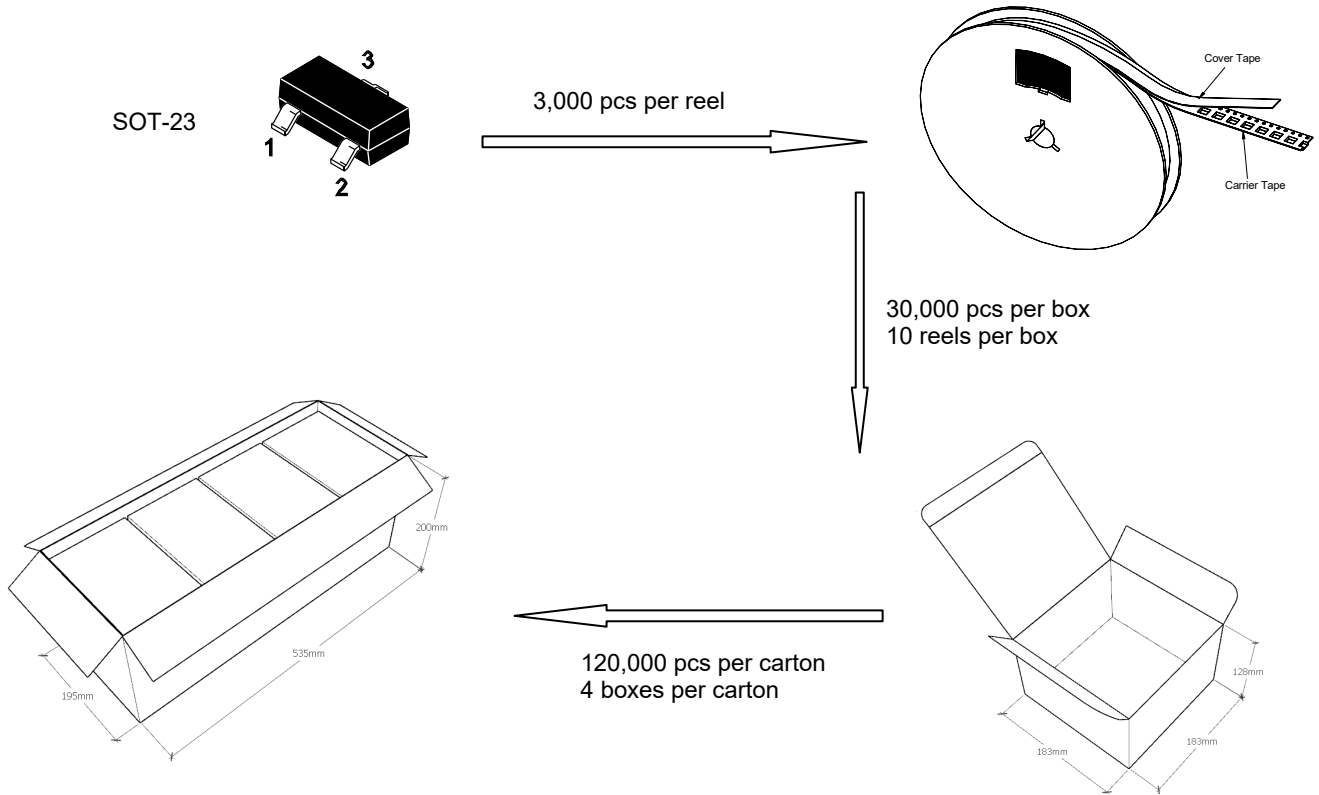

### ◆ Embossed tape and reel data

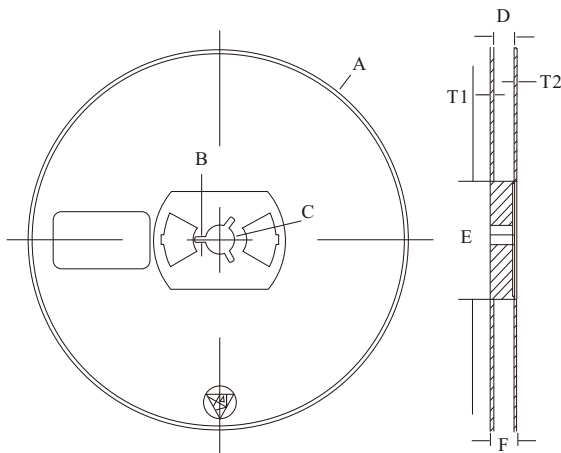

Symbol	Value (unit: mm)
A	Ø 177.8±1
B	2.7±0.2
C	Ø 13.5±0.2
E	Ø 54.5±0.2
F	12.3±0.3
D	9.6+2/-0.3
T1	1.0±0.2
T2	1.2±0.2

Reel (7")

