

Features

- For Switching and AF Amplifier Applications.

Equivalent Circuit

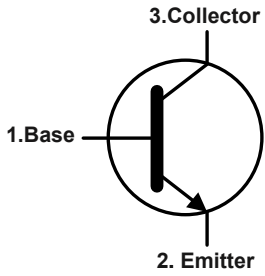

SOT-23

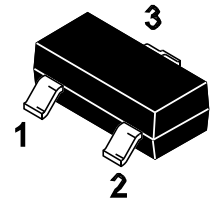

1.Base 2.Emitter 3.Collector

Marking Code : 3D

Absolute Maximum Ratings

Ratings at 25°C ambient temperature unless otherwise specified.

Parameter	Symbol	Value	Unit
Collector Base Voltage	V_{CB0}	500	V
Collector Emitter Voltage	V_{CEO}	400	V
Emitter Base Voltage	V_{EBO}	6	V
Collector Current	I_c	300	mA
Maximum Power Dissipation	P_D	350	mW
Junction Temperature	T_J	150	°C
Storage Temperature Range	T_{STG}	-55 to +150	°C



Electrical Characteristics (T_A=25°C)

Parameter	Symbol	Min.	Max.	Unit
DC Current Gain at V _{CE} = 10 V, I _C = 1 mA at V _{CE} = 10 V, I _C = 10 mA at V _{CE} = 10 V, I _C = 50 mA at V _{CE} = 10 V, I _C = 100 mA	H _{FE}	40 50 45 40	-- 200 -- --	--
Collector Base Cutoff Current at V _{CB} = 400 V	I _{CBO}	--	0.1	μA
Collector Emitter Cutoff Current at V _{CE} = 400 V	I _{CEO}	--	0.5	μA
Emitter Base Cutoff Current at V _{EB} = 4 V	I _{EBO}	--	0.1	μA
Collector Base Breakdown Voltage at I _C = 100 μA	V _{(BR)CBO}	500	--	V
Collector Emitter Breakdown Voltage at I _C = 1 mA	V _{(BR)CEO}	400	--	V
Emitter Base Breakdown Voltage at I _E = 100 μA	V _{(BR)EBO}	6	--	V
Collector Emitter Saturation Voltage at I _C = 1 mA, I _B = 0.1 mA at I _C = 10 mA, I _B = 1 mA at I _C = 50 mA, I _B = 5 mA	V _{CE(sat)}	-- -- --	0.4 0.5 0.75	V
Base Emitter Saturation Voltage at I _C = 10 mA, I _B = 1 mA	V _{BE(sat)}	--	0.75	V
Output Capacitance at V _{CB} = 20 V, f = 1 MHz	C _{ob}	--	7	pF



Typical Characteristic Curves

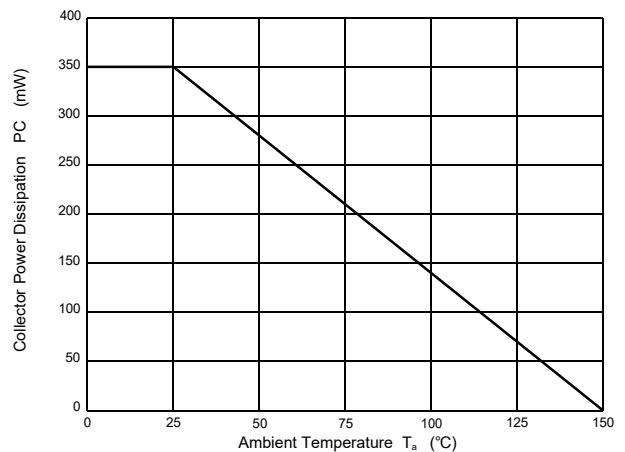
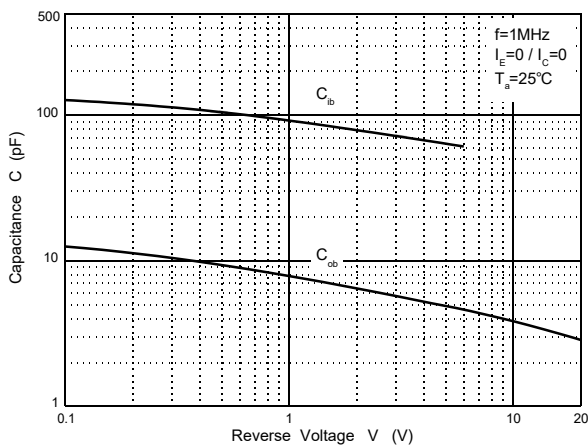
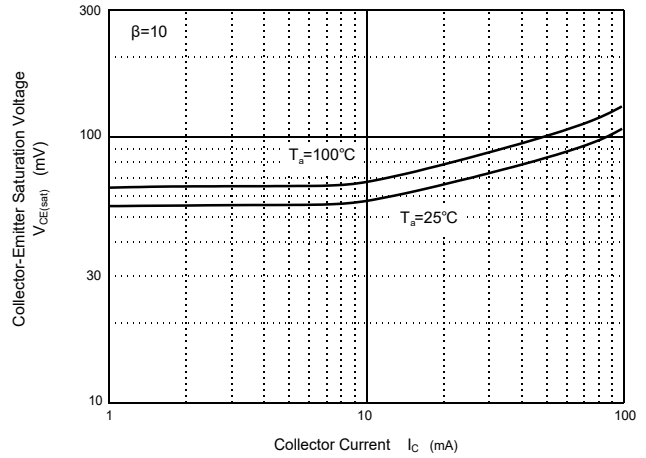
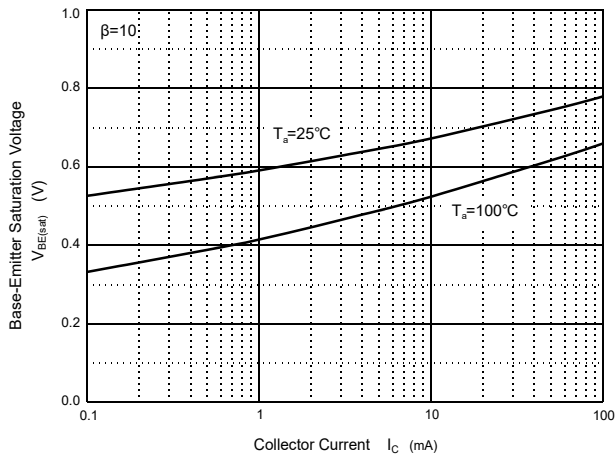
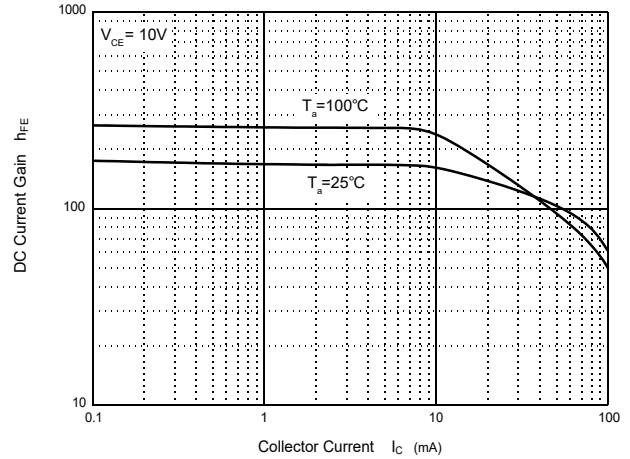
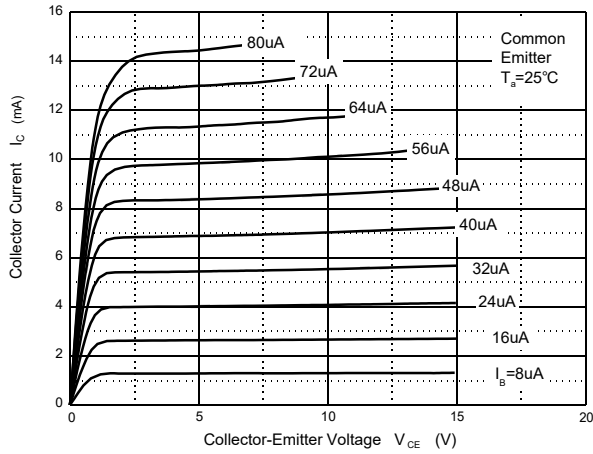

Package Outline

SOT-23

Dimensions in mm

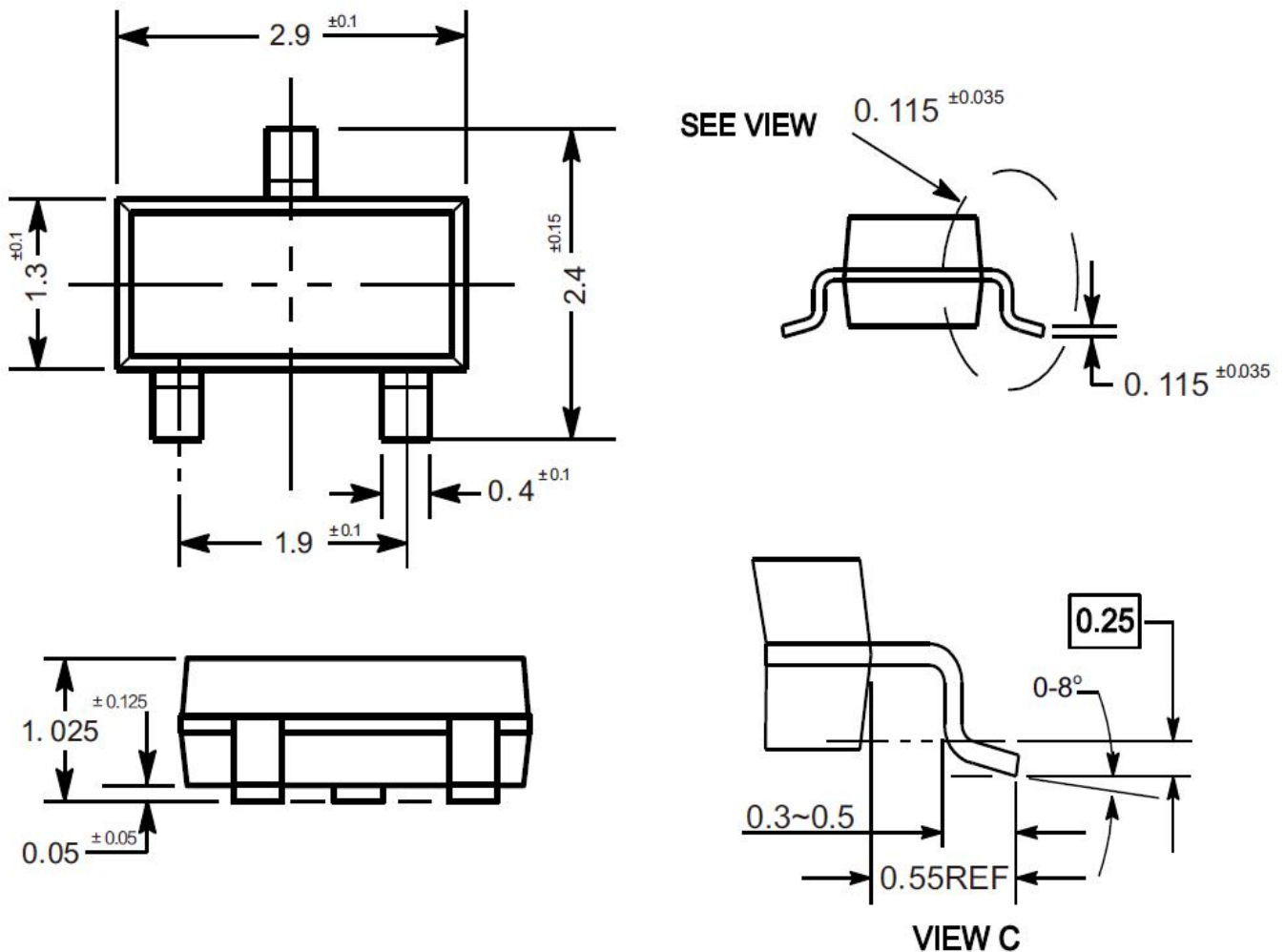

Ordering Information

Device	Package	Shipping
MMBTA44	SOT-23	3,000PCS/Reel&7inches

Conditions of Soldering and Storage

◆ Recommended condition of reflow soldering

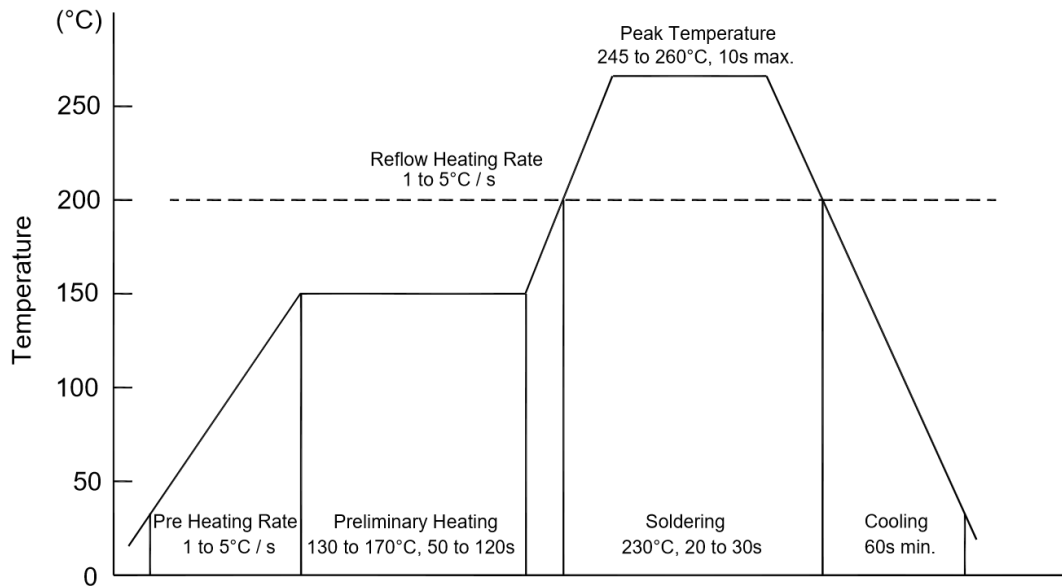

Recommended peak temperature is over 245 °C. If peak temperature is below 245 °C, you may adjust the following parameters:

- Time length of peak temperature (longer)
- Time length of soldering (longer)
- Thickness of solder paste (thicker)

◆ Conditions of hand soldering

- Temperature: 370 °C
- Time: 3s max.
- Times: one time

◆ Storage conditions

- **Temperature**
5 to 40 °C
- **Humidity**
30 to 80% RH
- **Recommended period**
One year after manufacturing

Package Specifications

- The method of packaging

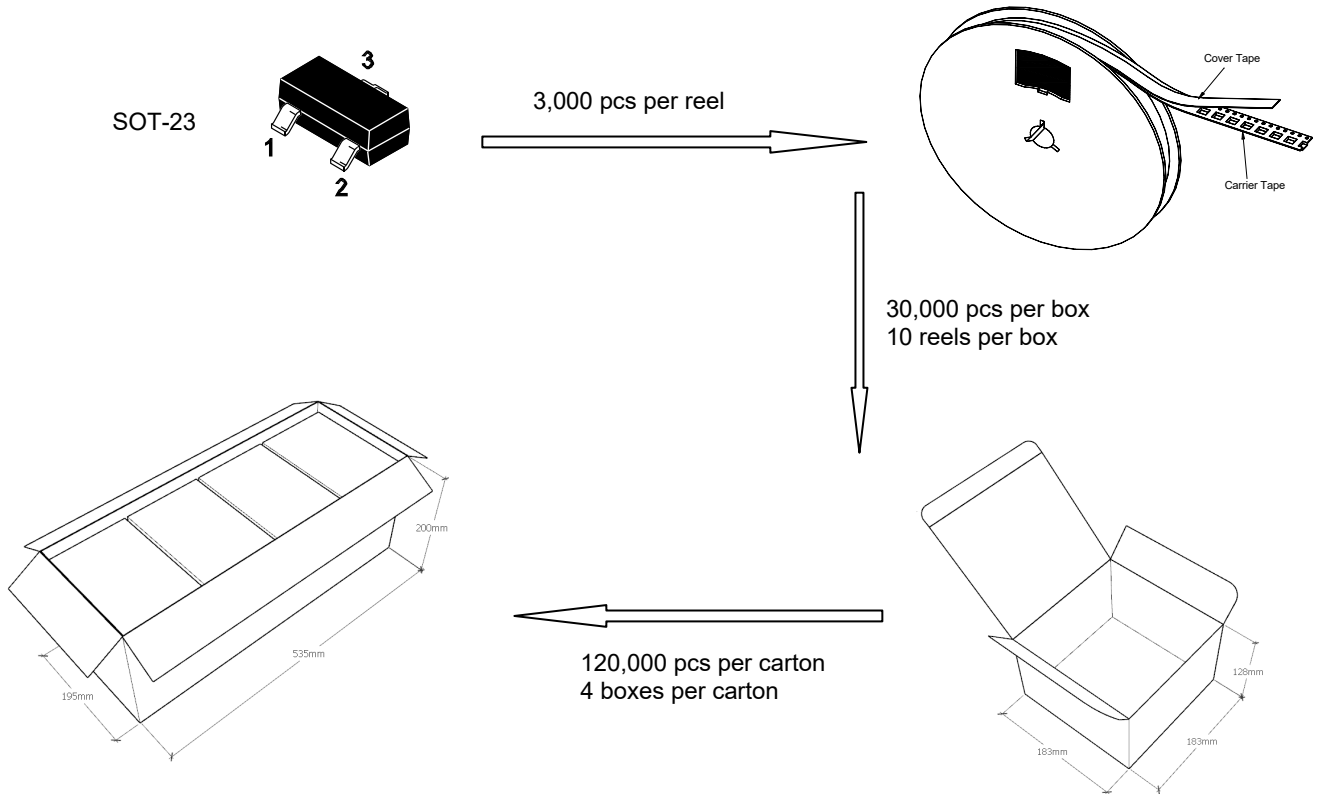

◆ Embossed tape and reel data

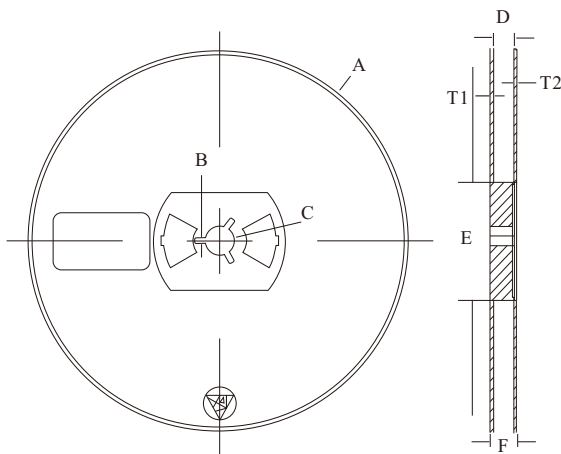

Symbol	Value (unit: mm)
A	$\varnothing 177.8 \pm 1$
B	2.7 ± 0.2
C	$\varnothing 13.5 \pm 0.2$
E	$\varnothing 54.5 \pm 0.2$
F	12.3 ± 0.3
D	$9.6 + 2 / - 0.3$
T1	1.0 ± 0.2
T2	1.2 ± 0.2

Reel (7")

