

### Features

- For Switching and AF Amplifier Applications.

SOT-23

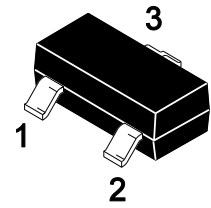

1.Base 2.Emitter 3.Collector

### Equivalent Circuit

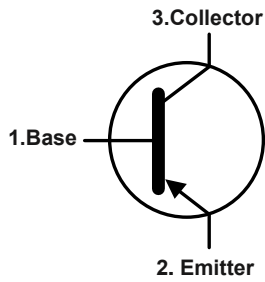

### Marking Code :

MMBTSA1015O : 10X

MMBTSA1015Y : 10Y

MMBTSA1015G : 10G

MMBTSA1015L : 10L

### Absolute Maximum Ratings

Ratings at 25°C ambient temperature unless otherwise specified.

Parameter	Symbol	Value	Unit
Collector Base Voltage	$-V_{CB0}$	50	V
Collector Emitter Voltage	$-V_{CEO}$	50	V
Emitter Base Voltage	$-V_{EBO}$	5	V
Collector Current	$-I_C$	150	mA
Maximum Power Dissipation	$P_D$	200	mW
Junction Temperature	$T_J$	150	°C
Storage Temperature Range	$T_{STG}$	-55 to +150	°C



### Electrical Characteristics (T<sub>A</sub>=25°C)

Parameter	Symbol	Min.	Max.	Unit
DC Current Gain at V <sub>CE</sub> = -6 V, I <sub>C</sub> = -2 mA Gain Group	O	70	140	--
	Y	120	240	
	G	200	400	
	L	350	700	
Collector Base Cutoff Current at V <sub>CB</sub> = -50 V	-I <sub>CBO</sub>	--	100	nA
Collector Emitter Cutoff Current at V <sub>CE</sub> = -50 V	-I <sub>CEO</sub>	--	1	μA
Emitter Base Cutoff Current at V <sub>EB</sub> = -5 V	-I <sub>EBO</sub>	--	100	nA
Collector Base Breakdown Voltage at I <sub>C</sub> = -100 μA	-V <sub>(BR)CBO</sub>	50	--	V
Collector Emitter Breakdown Voltage at I <sub>C</sub> = -0.1 mA	-V <sub>(BR)CEO</sub>	50	--	V
Emitter Base Breakdown Voltage at I <sub>E</sub> = -100 μA	-V <sub>(BR)EBO</sub>	5	--	V
Collector Emitter Saturation Voltage at I <sub>C</sub> = -100 mA, I <sub>B</sub> = -10 mA	-V <sub>CE(sat)</sub>	--	0.3	V
Base Emitter Saturation Voltage at I <sub>C</sub> = -100 mA, I <sub>B</sub> = -10 mA	-V <sub>BE(sat)</sub>	--	1.1	V
Transition Frequency at -V <sub>CE</sub> = 10 V, -I <sub>C</sub> = 1 mA, f = 30 MHz	F <sub>T</sub>	80	--	MHz
Output Capacitance at V <sub>CB</sub> = -10 V, f = 1MHz	C <sub>ob</sub>	--	7	pF

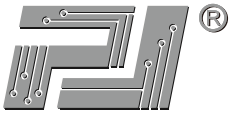

### Typical Characteristic Curves

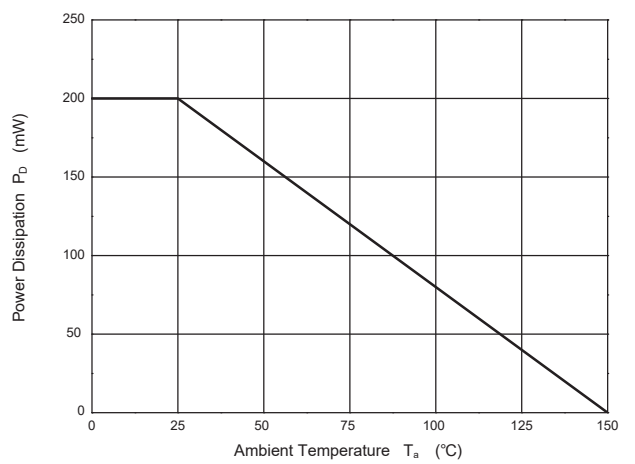
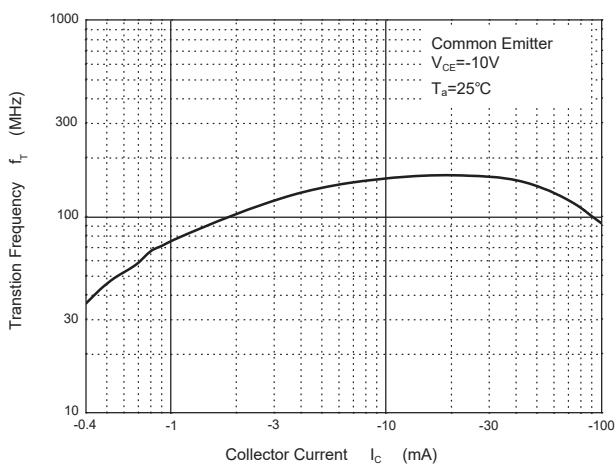
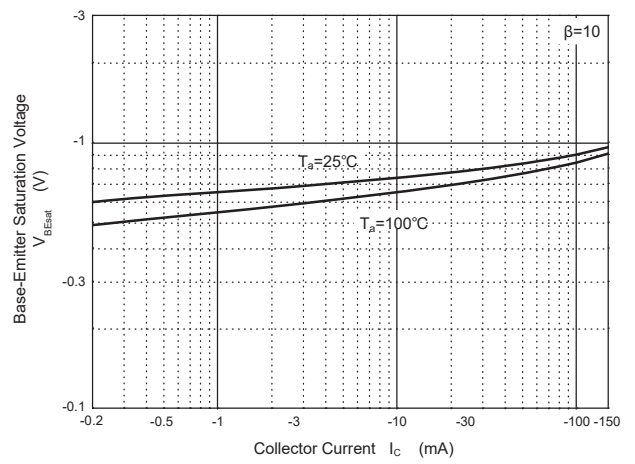
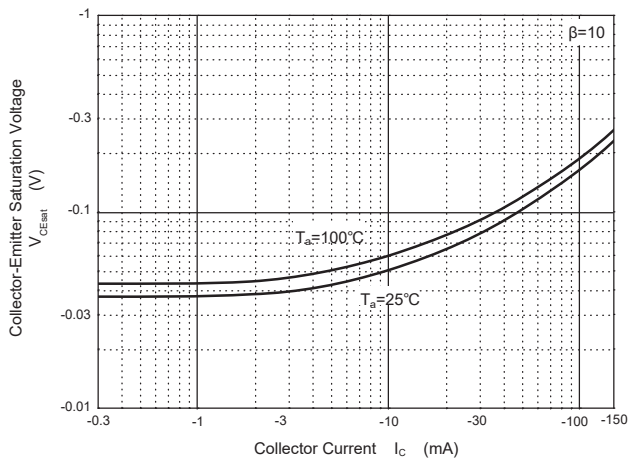
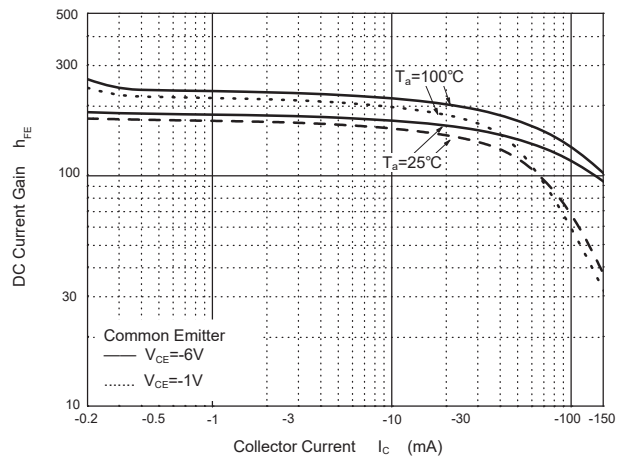
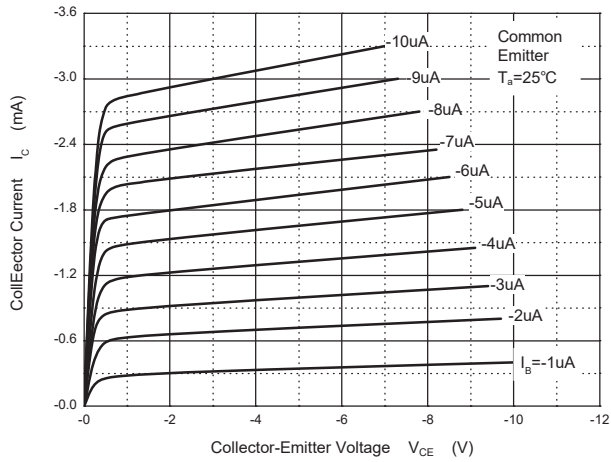

### Package Outline

SOT-23

Dimensions in mm

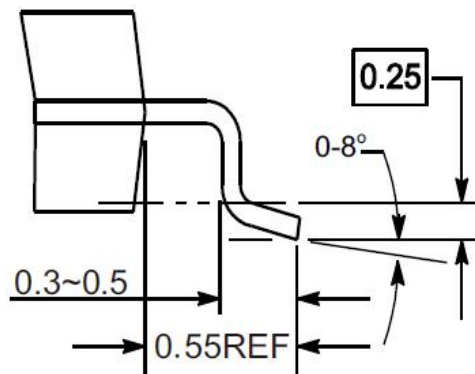
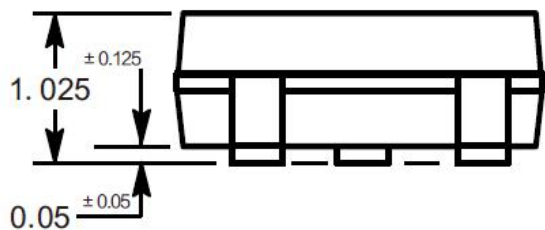
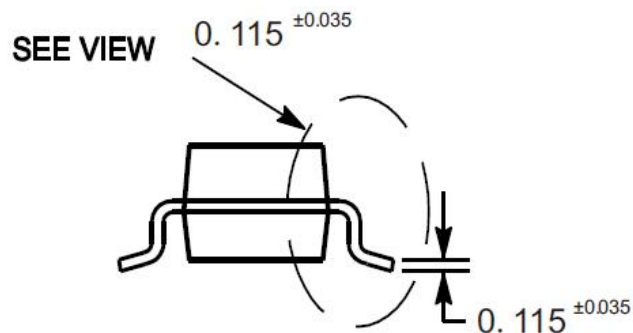
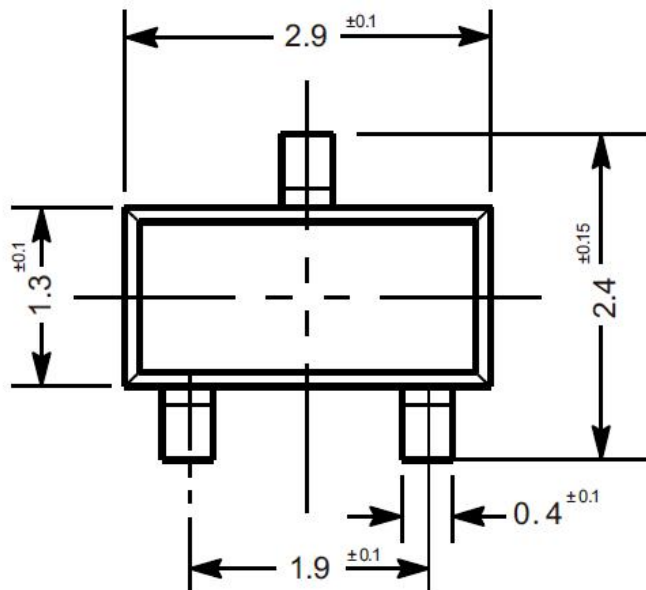

VIEW C

### Ordering Information

Device	Package	Shipping
MMBTSA1015	SOT-23	3,000PCS/Reel&7inches

### Conditions of Soldering and Storage

#### ◆ Recommended condition of reflow soldering

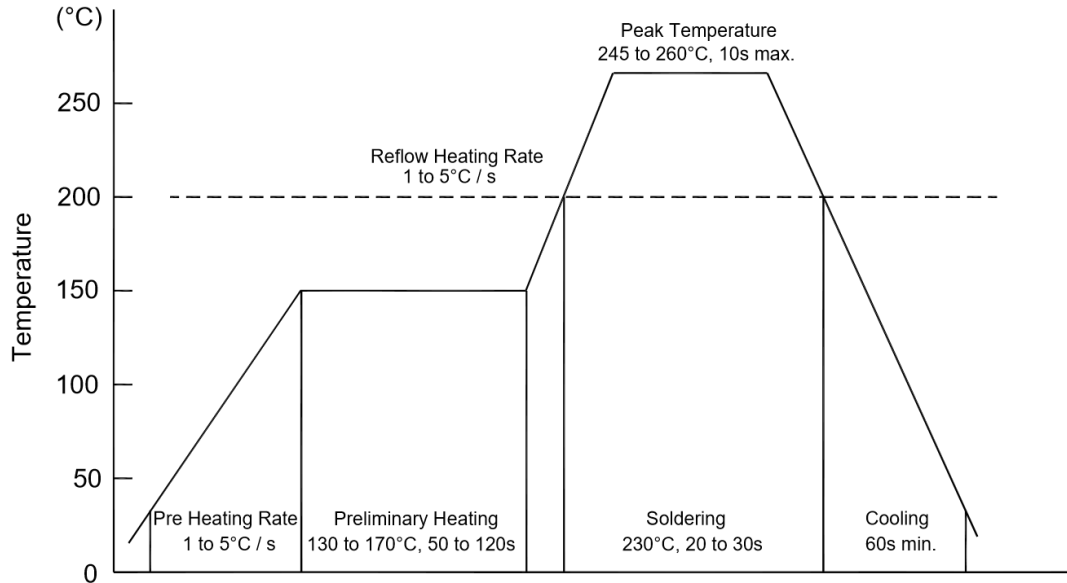

Recommended peak temperature is over 245 °C. If peak temperature is below 245 °C, you may adjust the following parameters:

- Time length of peak temperature (longer)
- Time length of soldering (longer)
- Thickness of solder paste (thicker)

#### ◆ Conditions of hand soldering

- Temperature: 370 °C
- Time: 3s max.
- Times: one time

#### ◆ Storage conditions

- **Temperature**  
5 to 40 °C
- **Humidity**  
30 to 80% RH
- **Recommended period**  
One year after manufacturing

### Package Specifications

- The method of packaging

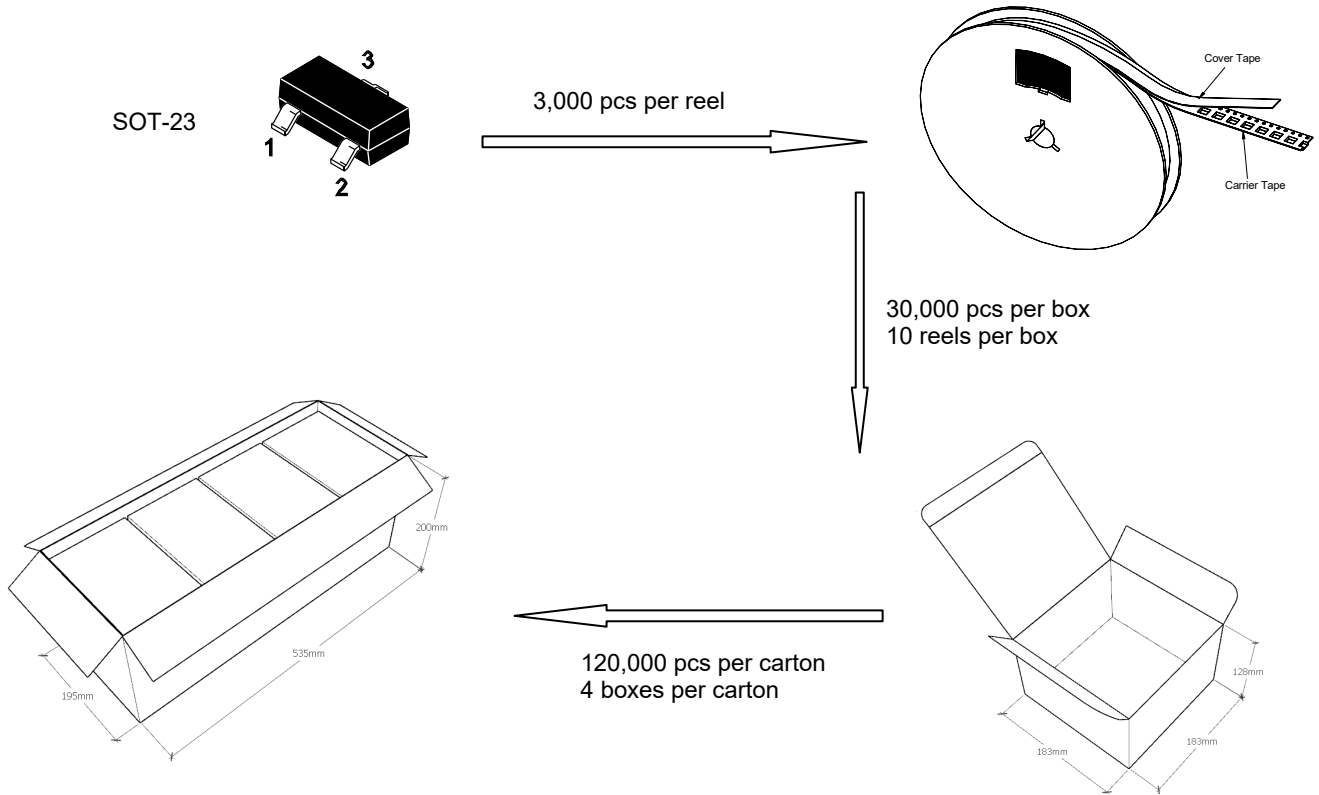

### ◆ Embossed tape and reel data

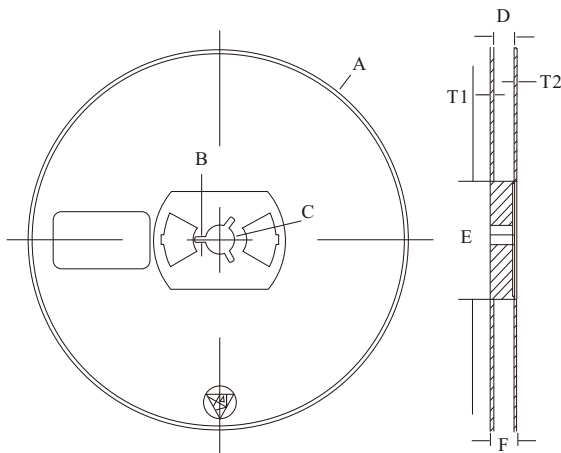

Symbol	Value (unit: mm)
A	Ø 177.8±1
B	2.7±0.2
C	Ø 13.5±0.2
E	Ø 54.5±0.2
F	12.3±0.3
D	9.6+2/-0.3
T1	1.0±0.2
T2	1.2±0.2

Reel (7")

