

Features

- For Switching and AF Amplifier Applications.

Equivalent Circuit

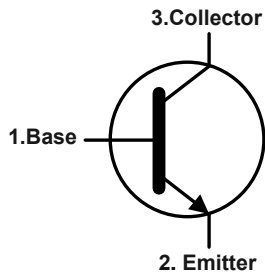

SOT-23

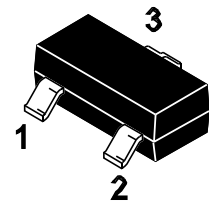

1.Base 2.Emitter 3.Collector

Marking Code :

MMBTSC1815O : 8O

MMBTSC1815Y : 8Y

MMBTSC1815G : 8G

MMBTSC1815L : 8L

Absolute Maximum Ratings

Ratings at 25°C ambient temperature unless otherwise specified.

Parameter	Symbol	Value	Unit
Collector Base Voltage	V_{CB0}	60	V
Collector Emitter Voltage	V_{CEO}	50	V
Emitter Base Voltage	V_{EBO}	5	V
Collector Current	I_c	150	mA
Maximum Power Dissipation	P_D	200	mW
Junction Temperature	T_J	150	°C
Storage Temperature Range	T_{STG}	-55 to +150	°C



Electrical Characteristics (T_A=25°C)

Parameter	Symbol	Min.	Max.	Unit
DC Current Gain at V _{CE} = 6 V, I _C = 2 mA	Gain Group			
	O	70	140	
	Y	120	240	--
	G	200	400	
	L	350	700	
Collector Base Cutoff Current at V _{CB} = 60V	I _{CBO}	--	100	nA
Collector Base Cutoff Current at V _{CE} = 50V	I _{CEO}	--	100	nA
Emitter Base Cutoff Current at V _{EB} = 5 V	I _{EBO}	--	100	nA
Collector Base Breakdown Voltage at I _C = 100 μA	V _{(BR)CBO}	60	--	V
Collector Emitter Breakdown Voltage at I _C = 0.1 mA	V _{(BR)CEO}	50	--	V
Emitter Base Breakdown Voltage at I _E = 100 μA	V _{(BR)EBO}	5	--	V
Collector Emitter Saturation Voltage at I _C = 100 mA, I _B = 10 mA	V _{CE(sat)}	--	0.25	V
Base Emitter Saturation Voltage at I _C = 100 mA, I _B = 10 mA	V _{BE(sat)}	--	1	V
Transition Frequency at V _{CE} = 10 V, I _C = 1 mA, f = 30 MHz	F _T	80	--	MHz
Output Capacitance at V _{CB} = 10 V, f = 1 MHz	C _{ob}	--	3.5	pF



Typical Characteristic Curves

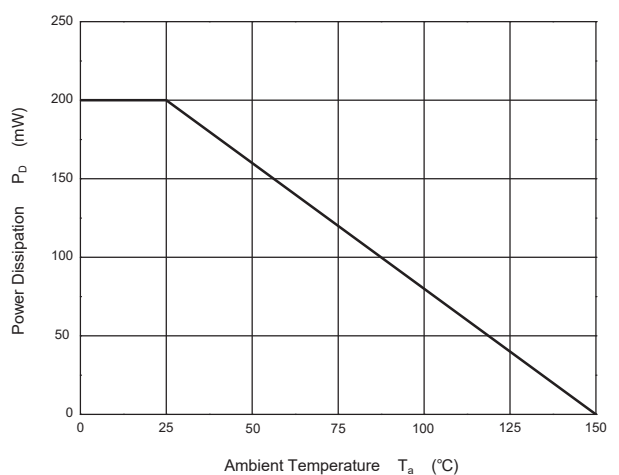
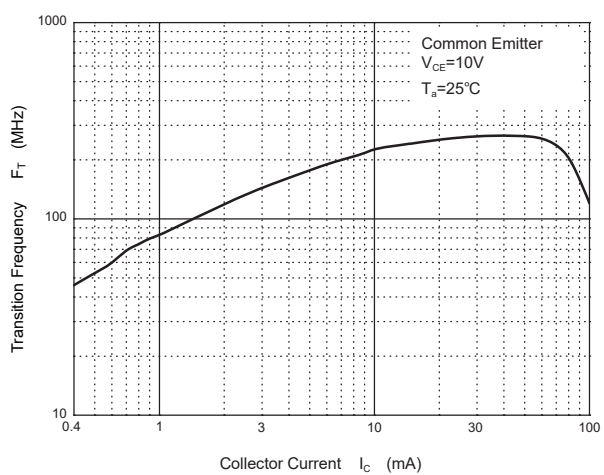
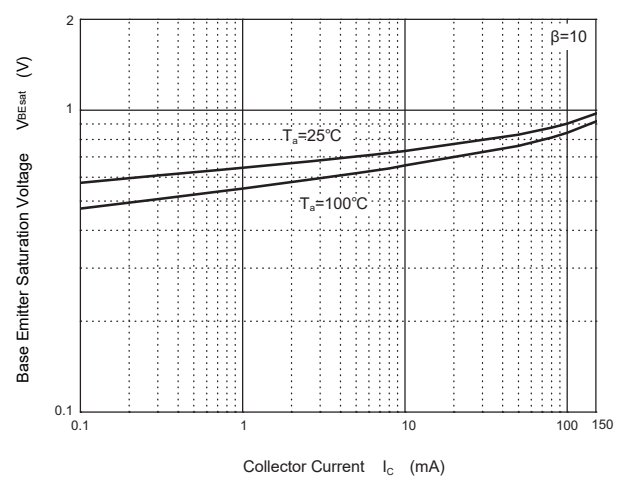
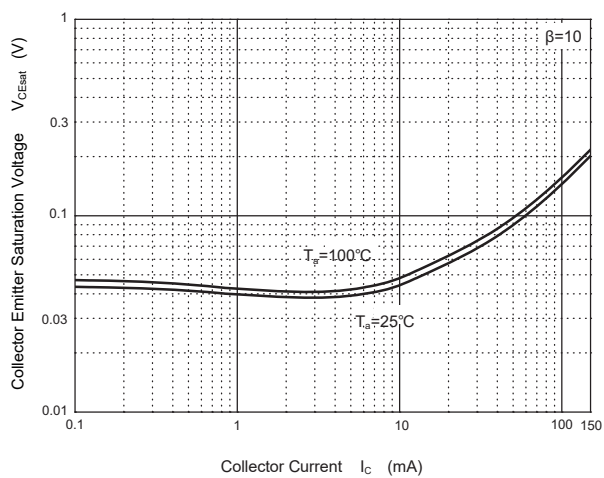
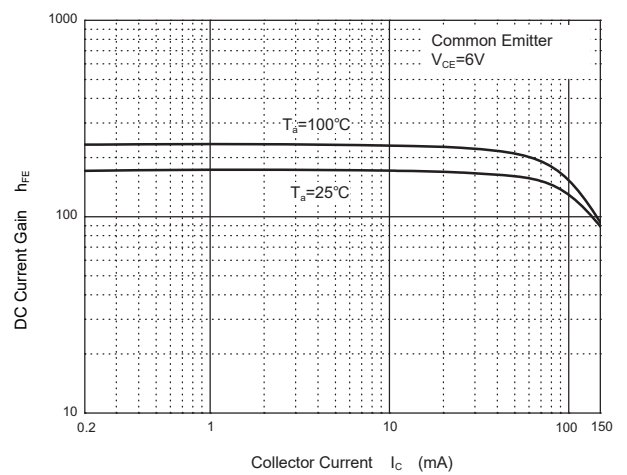
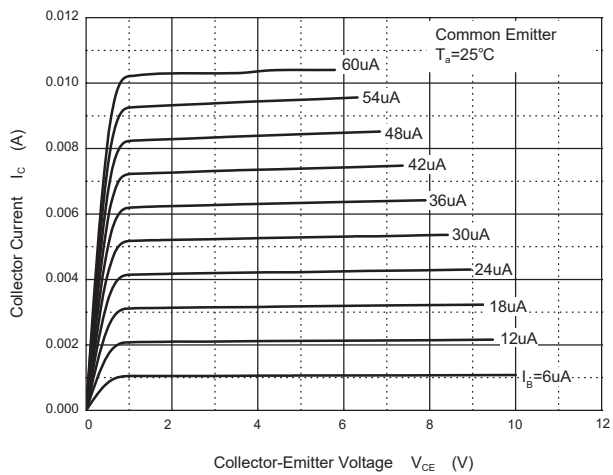

Package Outline

SOT-23

Dimensions in mm

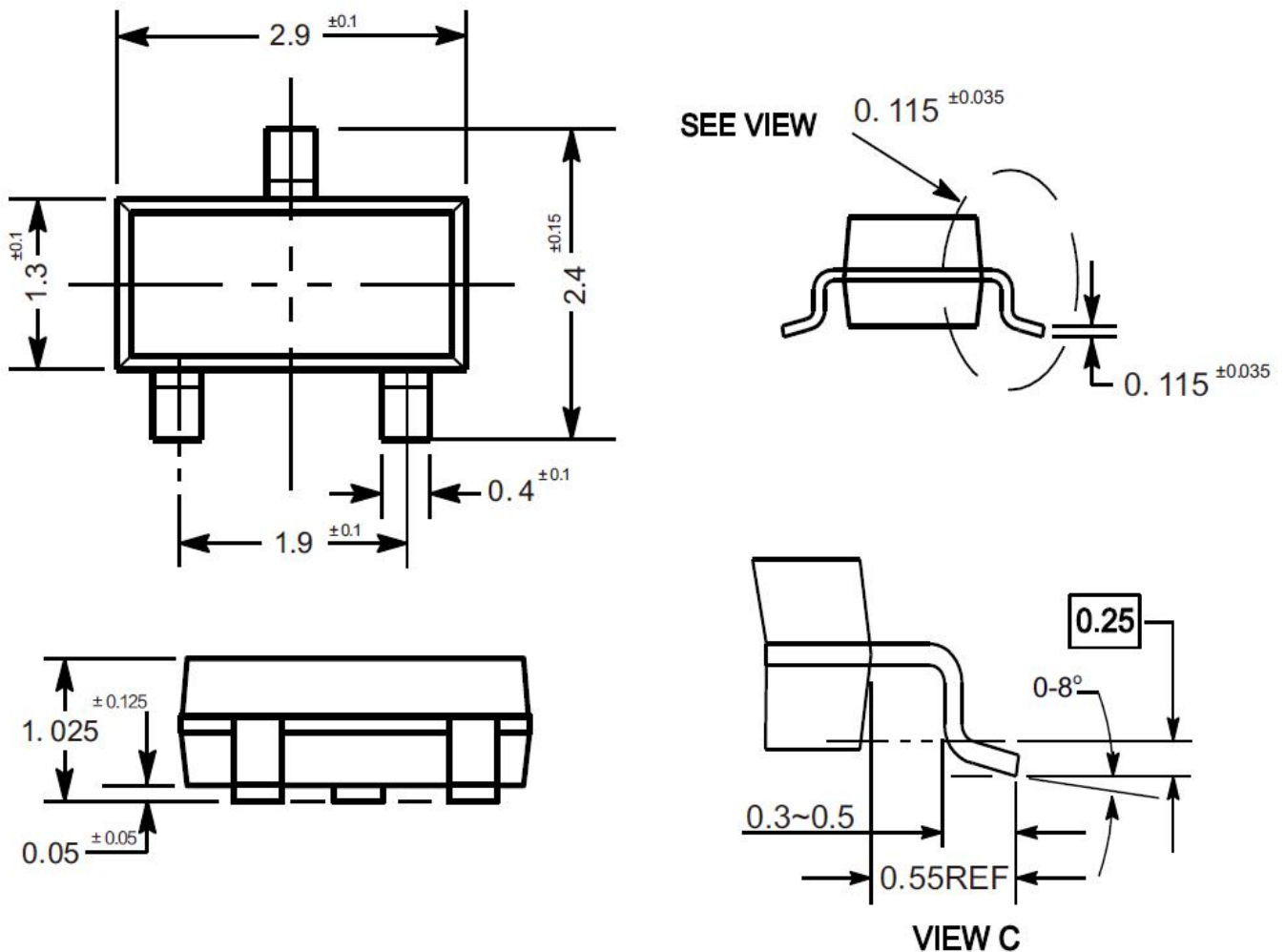

Ordering Information

Device	Package	Shipping
MMBTSC1815	SOT-23	3,000PCS/Reel&7inches

Conditions of Soldering and Storage

◆ Recommended condition of reflow soldering

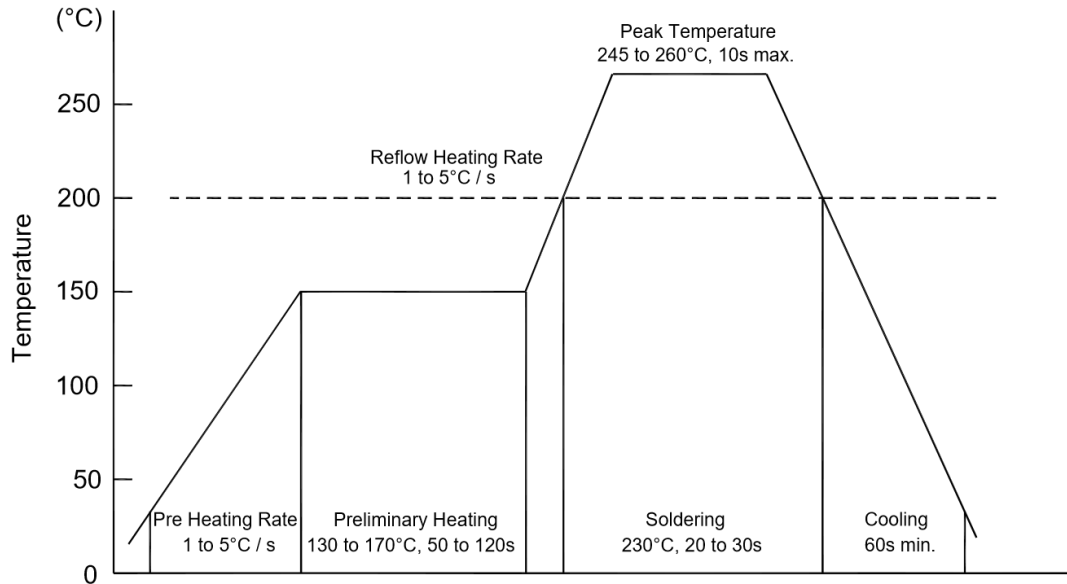

Recommended peak temperature is over 245 °C. If peak temperature is below 245 °C, you may adjust the following parameters:

- Time length of peak temperature (longer)
- Time length of soldering (longer)
- Thickness of solder paste (thicker)

◆ Conditions of hand soldering

- Temperature: 370 °C
- Time: 3s max.
- Times: one time

◆ Storage conditions

- **Temperature**
5 to 40 °C
- **Humidity**
30 to 80% RH
- **Recommended period**
One year after manufacturing

Package Specifications

- The method of packaging

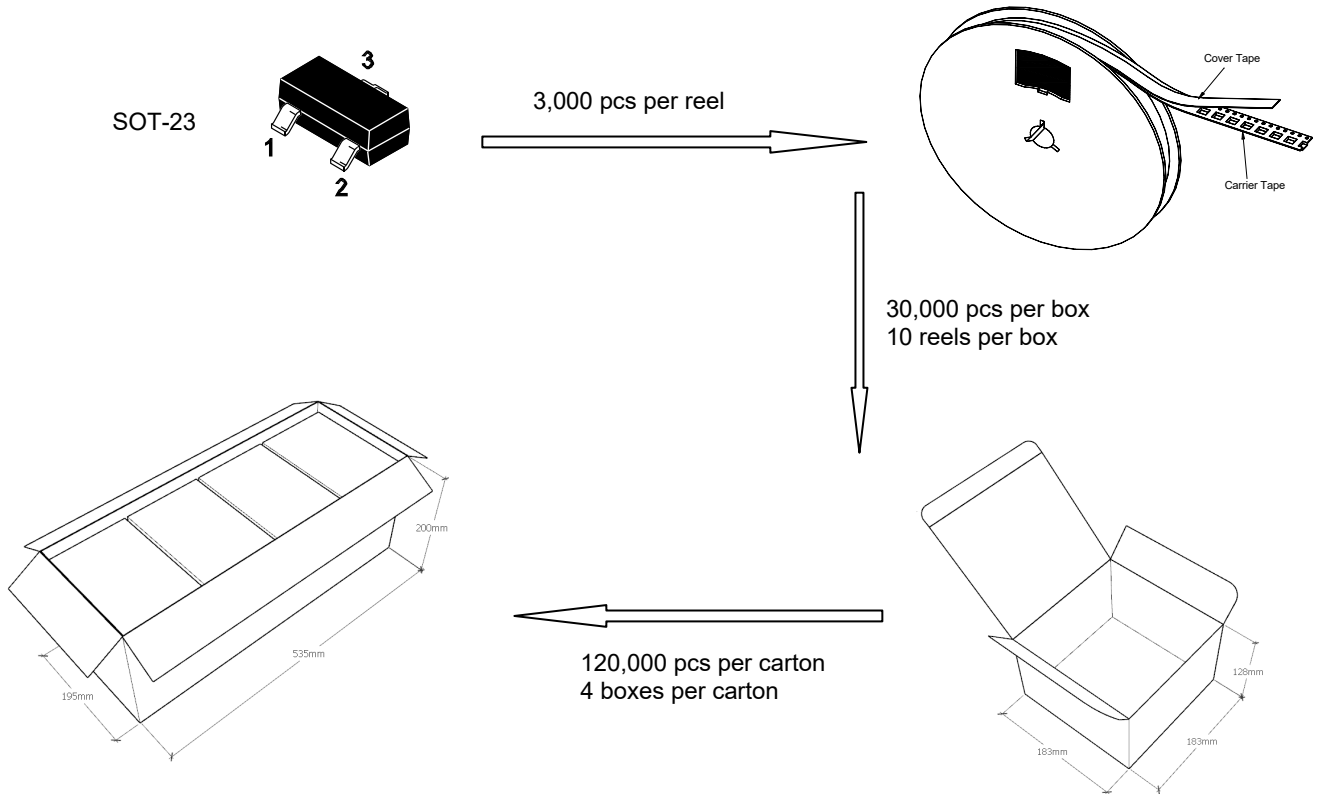

◆ Embossed tape and reel data

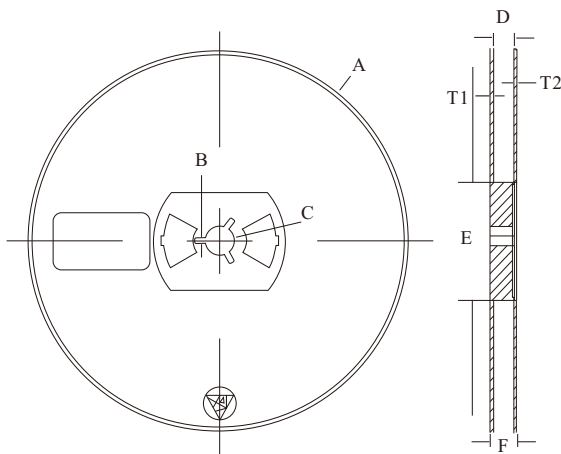

Symbol	Value (unit: mm)
A	$\varnothing 177.8 \pm 1$
B	2.7 ± 0.2
C	$\varnothing 13.5 \pm 0.2$
E	$\varnothing 54.5 \pm 0.2$
F	12.3 ± 0.3
D	$9.6 + 2 / - 0.3$
T1	1.0 ± 0.2
T2	1.2 ± 0.2

Reel (7")

