



PJM05N60SQ

N-Channel Enhancement Mode Power MOSFET

Product Summary

- $V_{DS} = 60V, I_D = 5A$
- $R_{DS(on)} < 45m\Omega @ V_{GS} = 10V$
- $R_{DS(on)} < 60m\Omega @ V_{GS} = 4.5V$

Features

- Advanced Trench Technology
- RoHS and Reach Compliant
- Halogen and Antimony Free
- Moisture Sensitivity Level 1

Application

- Power Switching Application
- Uninterruptible Power Supply

Marking Code

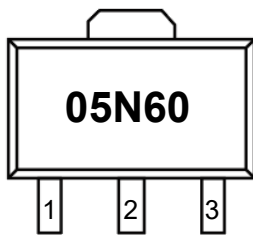

SOT-89

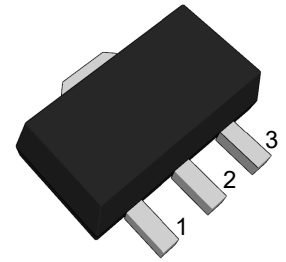

(Top View)

Pin	Description
1	Gate
2	Drain
3	Source

Schematic Diagram

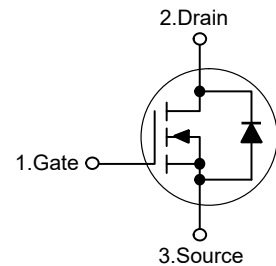

Absolute Maximum Ratings

Ratings at 25°C ambient temperature unless otherwise specified.

Parameter	Symbol	Value	Unit
Drain-Source Voltage	V_{DS}	60	V
Gate-Source Voltage	V_{GS}	± 20	V
Drain Current-Continuous	I_D	5	A
Drain Current-Pulsed ^{Note1}	I_{DM}	20	A
Maximum Power Dissipation	P_D	1.2	W
Junction Temperature	T_J	150	°C
Storage Temperature Range	T_{STG}	-55 to +150	°C

Thermal Characteristics

Thermal Resistance, Junction-to-Ambient ^{Note2}	$R_{\theta JA}$	104	°C/W
--	-----------------	-----	------



PJM05N60SQ

N-Channel Enhancement Mode Power MOSFET

Electrical Characteristics

(Ta=25°C unless otherwise specified)

Parameter	Symbol	Test Condition	Min.	Typ.	Max.	Unit
Static Characteristics						
Drain-Source Breakdown Voltage	$V_{(BR)DSS}$	$V_{GS}=0V, I_D=250\mu A$	60	--	--	V
Zero Gate Voltage Drain Current	I_{DSS}	$V_{DS}=60V, V_{GS}=0V$	--	--	1	μA
Gate-Body Leakage Current	I_{GSS}	$V_{GS}=\pm 20V, V_{DS}=0V$	--	--	± 100	nA
Gate Threshold Voltage ^{Note3}	$V_{GS(th)}$	$V_{DS}=V_{GS}, I_D=250\mu A$	1.2	1.6	2.5	V
Drain-Source On-Resistance ^{Note3}	$R_{DS(on)}$	$V_{GS}=10V, I_D=5A$	--	31	45	m Ω
		$V_{GS}=4.5V, I_D=5A$	--	37	55	m Ω
Forward Transconductance ^{Note3}	g_{FS}	$V_{DS}=5V, I_D=1A$	--	4	--	S
Dynamic Characteristics						
Input Capacitance	C_{iss}	$V_{DS}=15V, V_{GS}=0V, f=1MHz$	--	870	--	pF
Output Capacitance	C_{oss}		--	87	--	pF
Reverse Transfer Capacitance	C_{rss}		--	70	--	pF
Total Gate Charge	Q_g	$V_{DS}=30V, I_D=4.5A$ $, V_{GS}=10V$	--	14	--	nC
Gate-Source Charge	Q_{gs}		--	2.9	--	nC
Gate-Drain Charge	Q_{gd}		--	5.2	--	nC
Switching Characteristics						
Turn-on Delay Time	$t_{d(on)}$	$V_{DD}=30V, I_D=2A,$ $V_{GS}=10V, R_{GEN}=3\Omega$ $R_L=6.7\Omega$	--	5	--	nS
Turn-on Rise Time	t_r		--	2.6	--	nS
Turn-off Delay Time	$t_{d(off)}$		--	16.1	--	nS
Turn-off Fall Time	t_f		--	2.3	--	nS
Source-Drain Diode Characteristics						
Diode Forward Voltage ^{Note3}	V_{SD}	$V_{GS}=0V, I_S=5A$	--	--	1.2	V
Diode Forward Current ^{Note2}	I_S		--	--	5	A

Note: 1. Repetitive Rating: Pulse width limited by maximum junction temperature.

2. Surface Mounted on FR4 Board, $t \leq 10$ sec.

3. Pulse Test: Pulse width $\leq 300\mu s$, duty cycle $\leq 0.5\%$.



PJM05N60SQ

N-Channel Enhancement Mode Power MOSFET

Typical Characteristic Curves

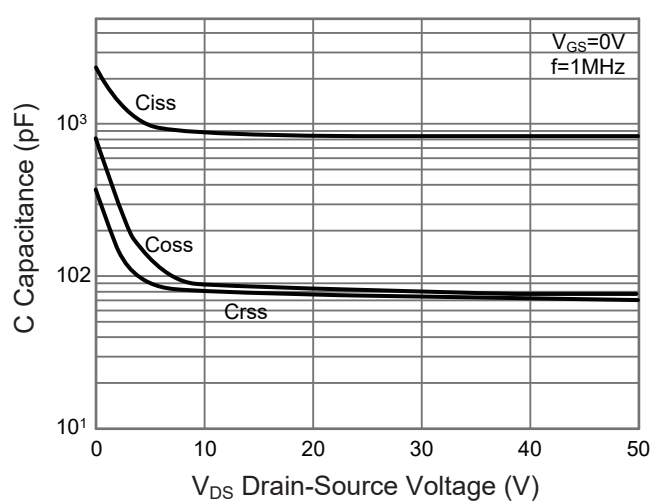
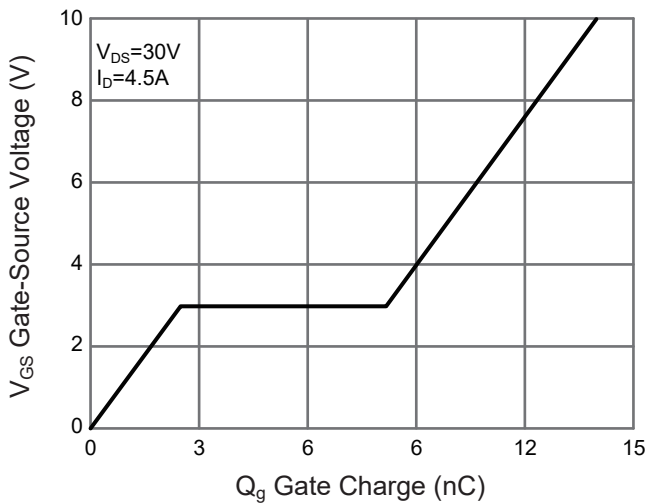
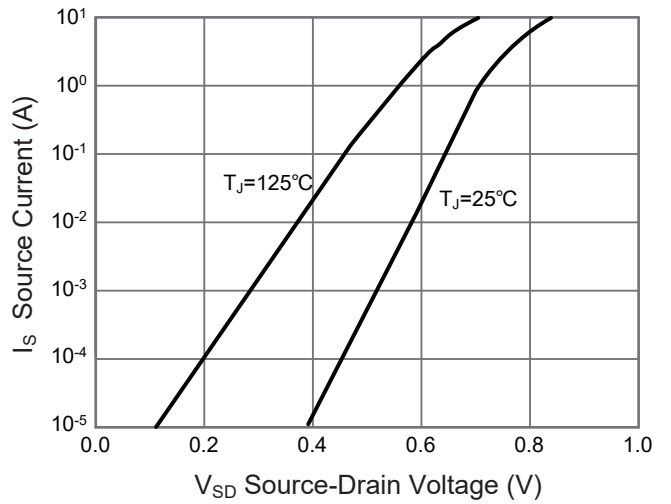
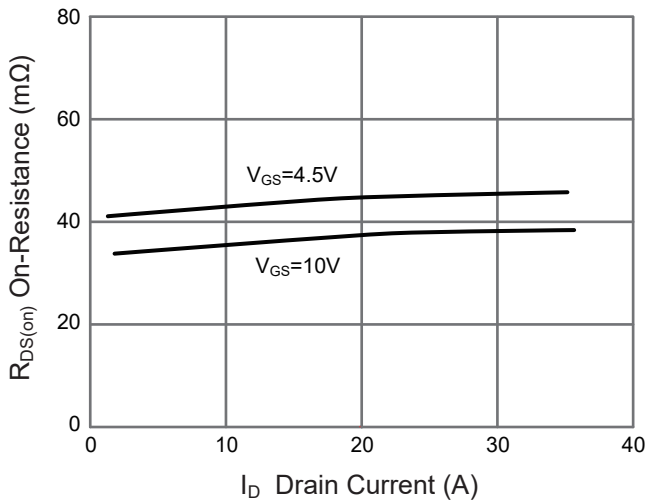
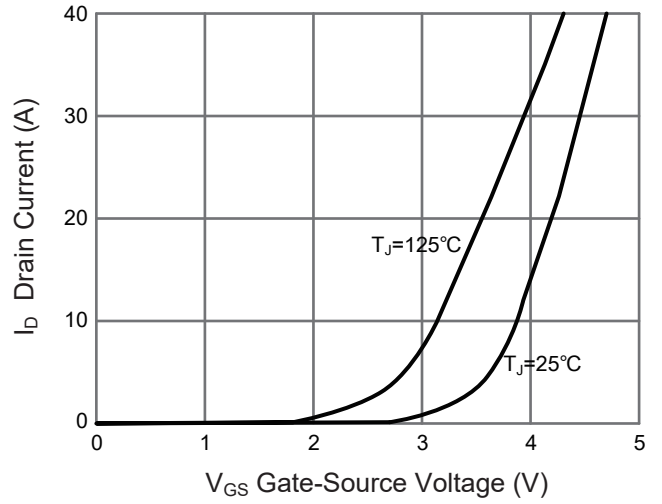
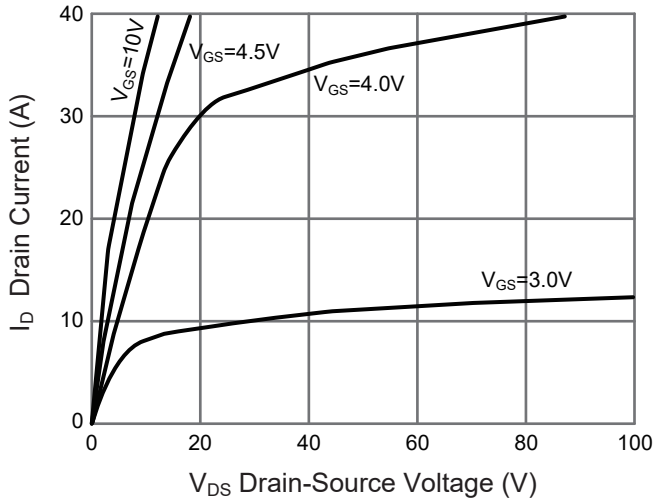



PJM05N60SQ

N-Channel Enhancement Mode Power MOSFET

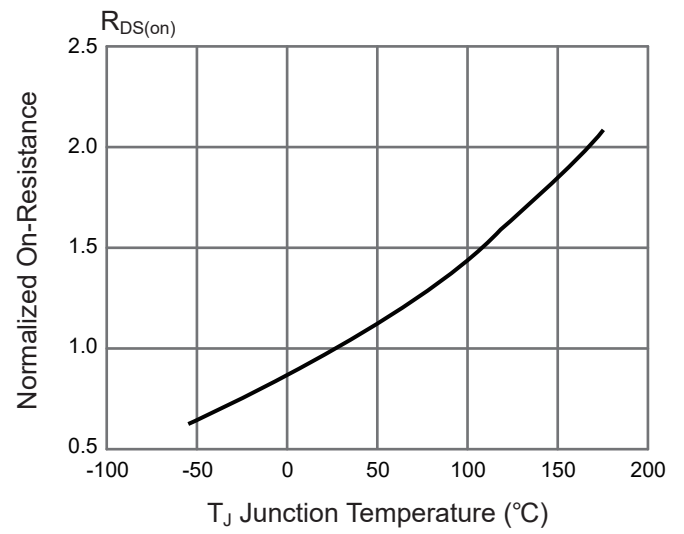
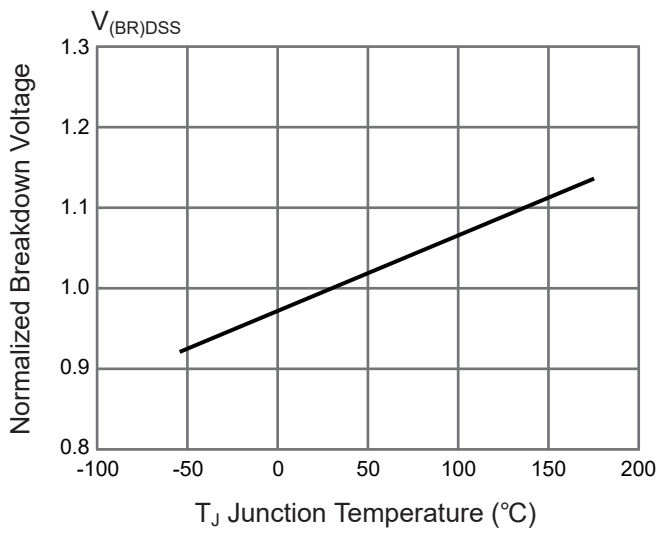



PJM05N60SQ

N-Channel Enhancement Mode Power MOSFET

Package Outline

SOT-89

Dimensions in mm

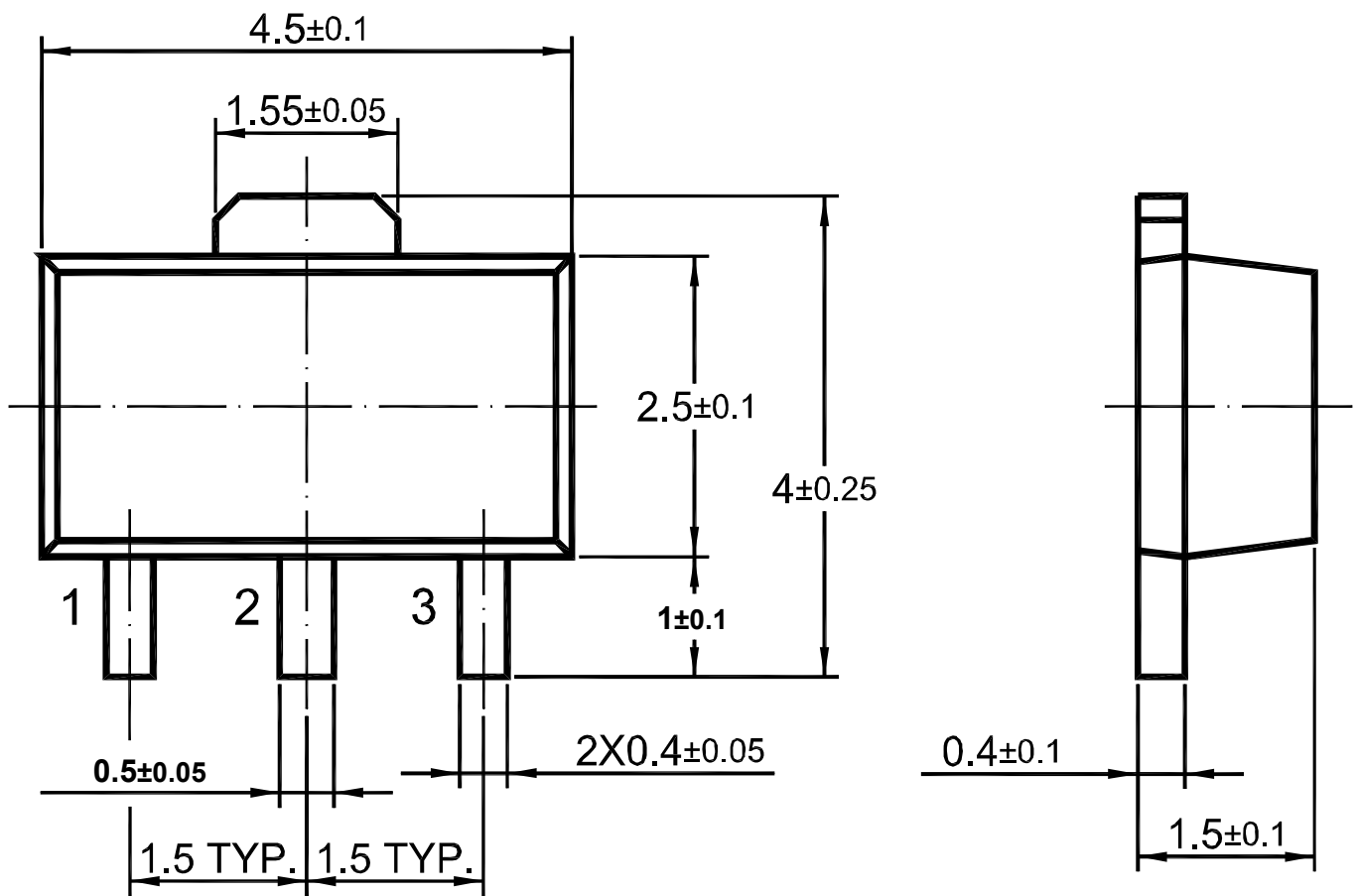

Ordering Information

Device	Package	Shipping
PJM05N60SQ	SOT-89	1,000PCS/Reel&7inches
		3,000PCS/Reel&13inches



Conditions of Soldering and Storage

◆ Recommended condition of reflow soldering

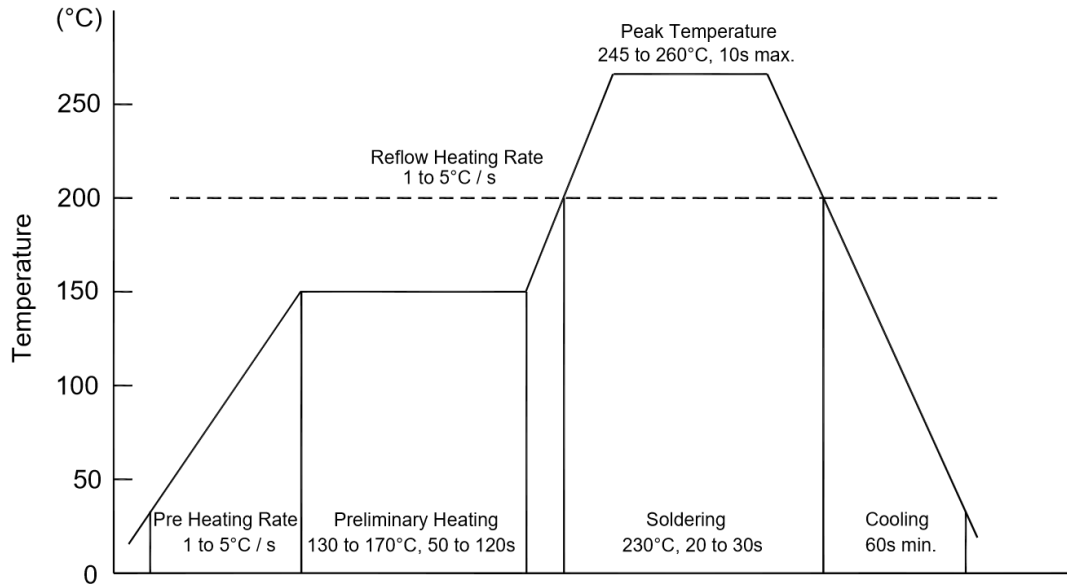

Recommended peak temperature is over 245°C. If peak temperature is below 245°C, you may adjust the following parameters:

- Time length of peak temperature (longer)
- Time length of soldering (longer)
- Thickness of solder paste (thicker)

◆ Conditions of hand soldering

- Temperature: 300°C
- Time: 3s max.
- Times: one time

◆ Storage conditions

- **Temperature**
5 to 40°C
- **Humidity**
30 to 80% RH
- **Recommended period**
One year after manufacturing



PJM05N60SQ

N-Channel Enhancement Mode Power MOSFET

Package Specifications

- The method of packaging (1,000PCS/Reel&7inches)

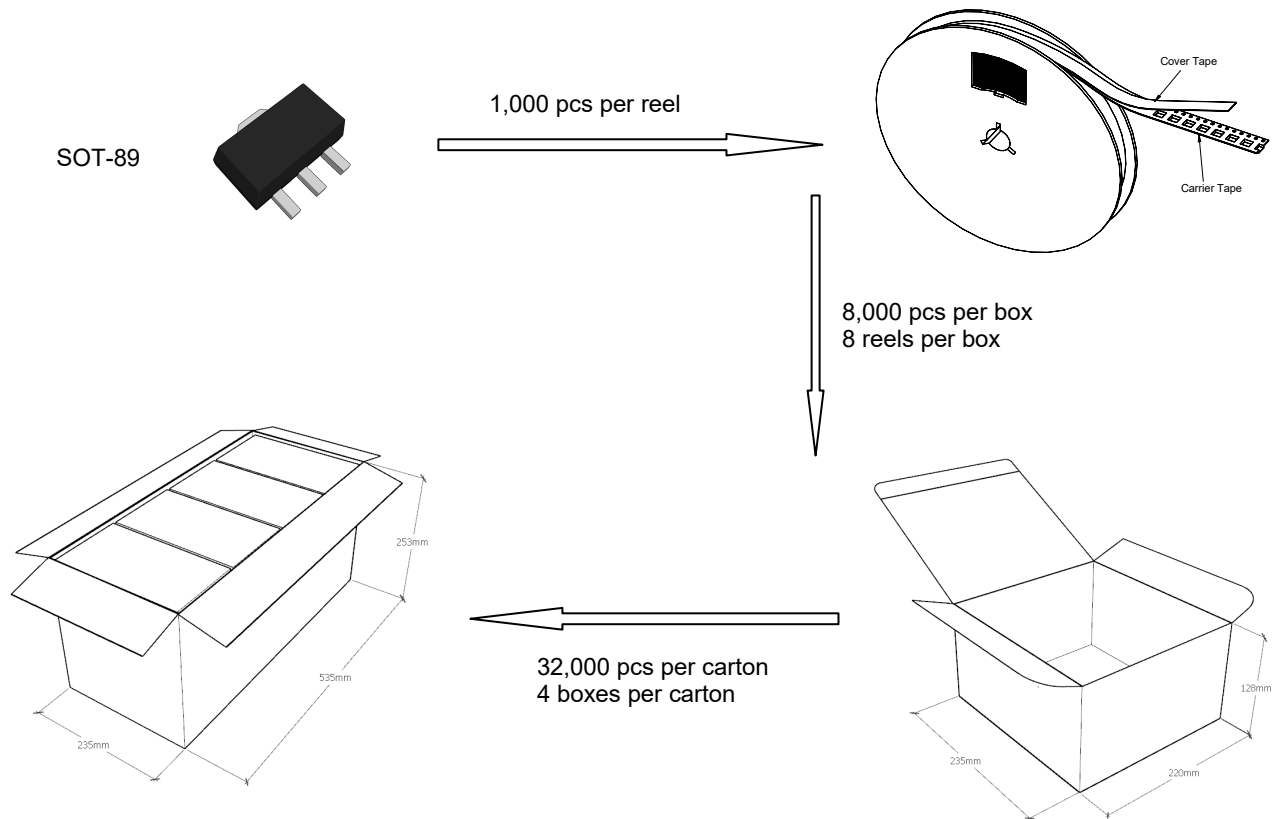

◆ Embossed tape and reel data

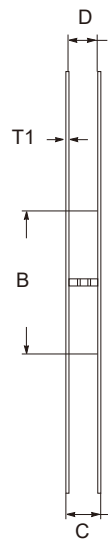
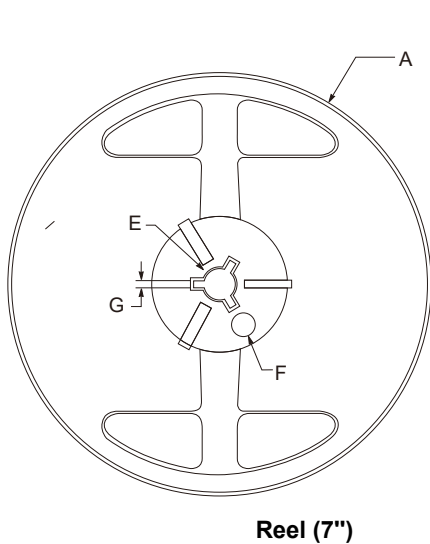

symbol	Value(unit:mm)
A	$\Phi 179 \pm 1$
B	60.5 ± 0.2
C	15.3 ± 0.3
D	$12.5 \sim 13.7$
E	$\Phi 13.5 \pm 0.2$
F	$\Phi 10.0 \pm 0.2$
G	2.7 ± 0.2
T1	1.0 ± 0.2

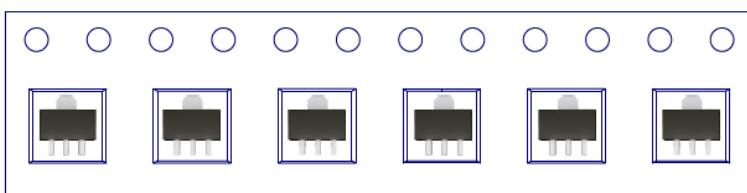



PJM05N60SQ

N-Channel Enhancement Mode Power MOSFET

Package Specifications

- The method of packaging (3,000PCS/Reel&13inches)

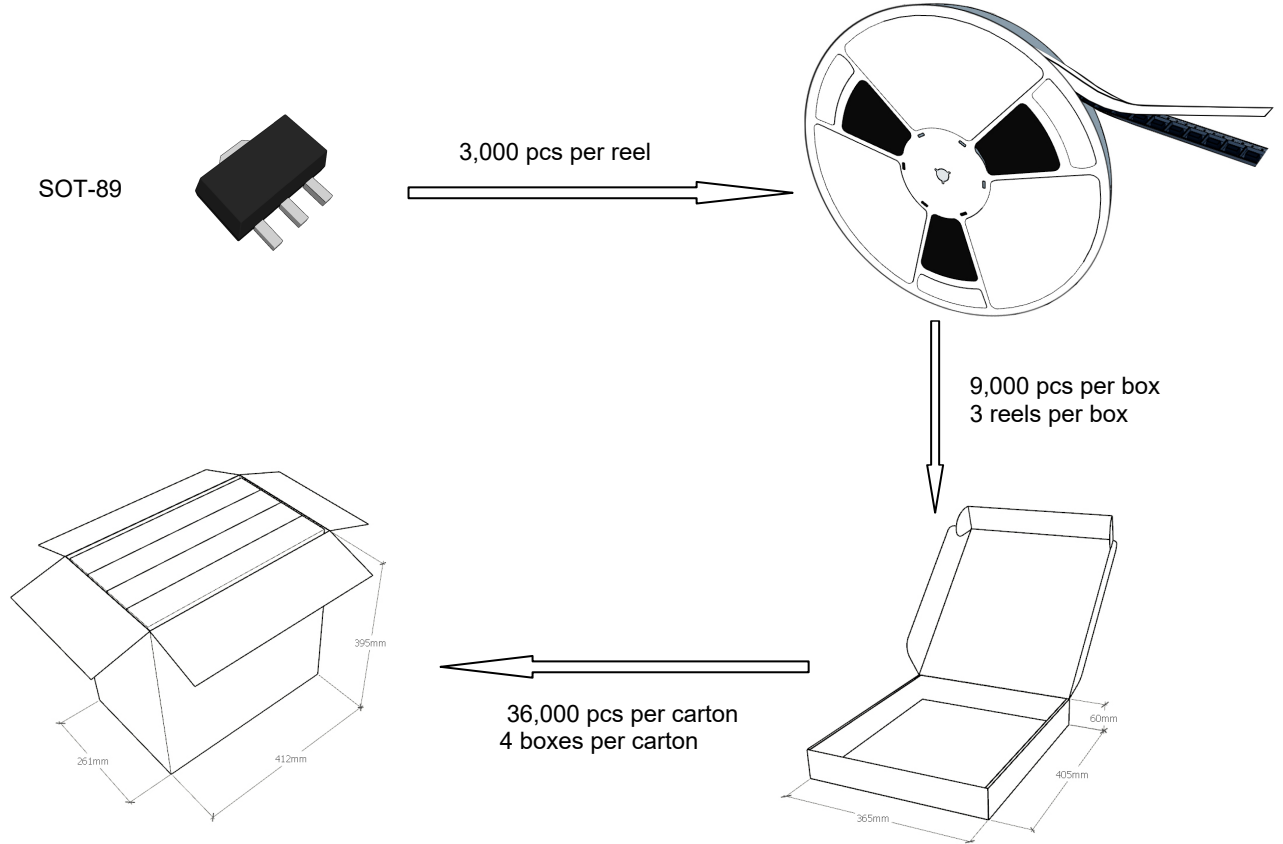

◆ Embossed tape and reel data

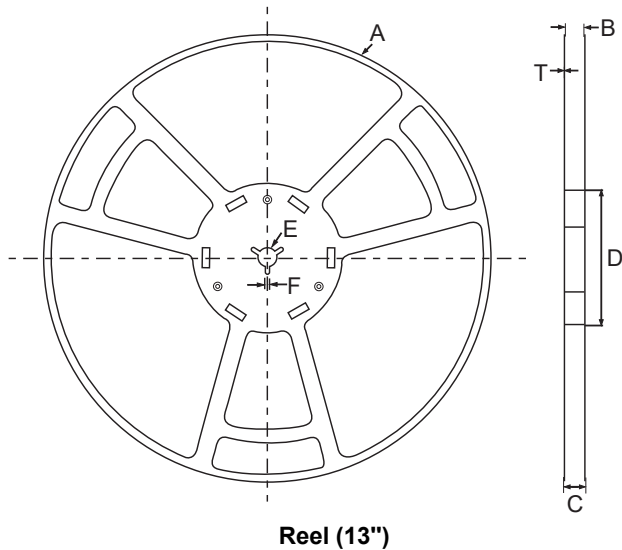

symbol	Value(unit:mm)
A	$\phi 330\pm 1$
B	12.7 ± 0.5
C	16.5 ± 0.3
D	$\phi 99.5\pm 0.5$
E	$\phi 13.6\pm 0.3$
F	2.8 ± 0.3
T	1.9 ± 0.2

