



PJM10H06NSQ

N-Channel Enhancement Mode Power MOSFET

Features

- Excellent $R_{DS(on)}$ and Low Gate Charge
- $V_{DS} = 100V, I_D = 6A$
 $R_{DS(on)} < 140m\Omega @ V_{GS} = 10V$

SOT-89

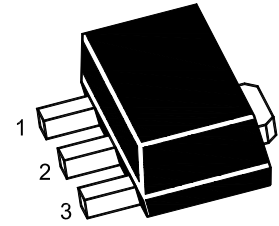

1. Gate 2.Drain 3.Source

Marking Code: 10H06

Applications

- Power Switching Application
- Uninterruptible Power Supply

Schematic Diagram

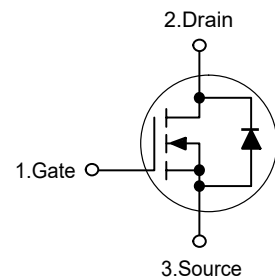

Absolute Maximum Ratings

Ratings at 25°C ambient temperature unless otherwise specified.

Parameter	Symbol	Value	Unit
Drain-Source Voltage	V_{DS}	100	V
Gate-Source Voltage	V_{GS}	± 20	V
Drain Current-Continuous	I_D	6	A
Drain Current-Pulsed ^{Note1}	I_{DM}	24	A
Maximum Power Dissipation	P_D	1.35	W
Junction Temperature	T_J	150	°C
Storage Temperature Range	T_{STG}	-55 to +150	°C

Thermal Characteristics

Thermal Resistance, Junction-to-Ambient ^{Note2}	$R_{\theta JA}$	92.5	°C/W
--	-----------------	------	------



PJM10H06NSQ

N-Channel Enhancement Mode Power MOSFET

Electrical Characteristics

(Ta=25°C unless otherwise specified)

Parameter	Symbol	Test Condition	Min.	Typ.	Max.	Unit
Static Characteristics						
Drain-Source Breakdown Voltage	$V_{(BR)DSS}$	$V_{GS}=0V, I_D=250\mu A$	100	--	--	V
Zero Gate Voltage Drain Current	I_{DSS}	$V_{DS}=100V, V_{GS}=0V$	--	--	1	μA
Gate-Body Leakage Current	I_{GSS}	$V_{GS}=\pm 20V, V_{DS}=0V$	--	--	± 100	nA
Gate Threshold Voltage ^{Note3}	$V_{GS(th)}$	$V_{DS}=V_{GS}, I_D=250\mu A$	1	1.8	2.5	V
Drain-Source On-Resistance ^{Note3}	$R_{DS(on)}$	$V_{GS}=10V, I_D=5A$	--	110	140	m Ω
Forward Transconductance ^{Note3}	g_{FS}	$V_{DS}=5V, I_D=2.9A$	--	8	--	S
Dynamic Characteristics						
Input Capacitance	C_{iss}	$V_{DS}=25V, V_{GS}=0V, f=1MHz$	--	690	--	pF
Output Capacitance	C_{oss}		--	120	--	pF
Reverse Transfer Capacitance	C_{rss}		--	90	--	pF
Switching Characteristics						
Turn-on Delay Time	$t_{d(on)}$	$V_{DD}=30V, R_L=15\Omega, I_D=2A, V_{GS}=10V, R_{GEN}=2.5\Omega$	--	11	--	nS
Turn-on Rise Time	t_r		--	7.4	--	nS
Turn-off Delay Time	$t_{d(off)}$		--	35	--	nS
Turn-off Fall Time	t_f		--	9.1	--	nS
Total Gate Charge	Q_g	$V_{DS}=30V, I_D=3A, V_{GS}=10V$	--	15.5	--	nC
Gate-Source Charge	Q_{gs}		--	3.2	--	nC
Gate-Drain Charge	Q_{gd}		--	4.7	--	nC
Source-Drain Diode Characteristics						
Diode Forward Voltage ^{Note3}	V_{SD}	$V_{GS}=0V, I_S=6A$	--	--	1.2	V
Diode Forward Current ^{Note2}	I_S		--	--	6	A

Note: 1. Repetitive Rating: Pulse width limited by maximum junction temperature.

2. Surface Mounted on FR4 Board, $t \leq 10$ sec.

3. Pulse Test: Pulse width $\leq 300\mu s$, duty cycle $\leq 2\%$.



PJM10H06NSQ

N-Channel Enhancement Mode Power MOSFET

Typical Characteristic Curves

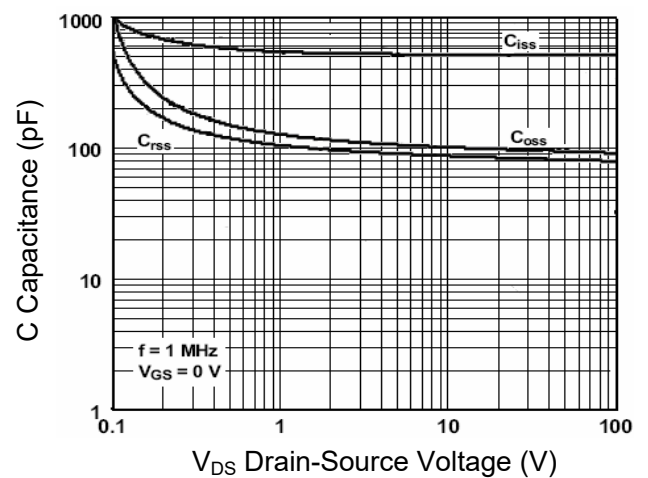
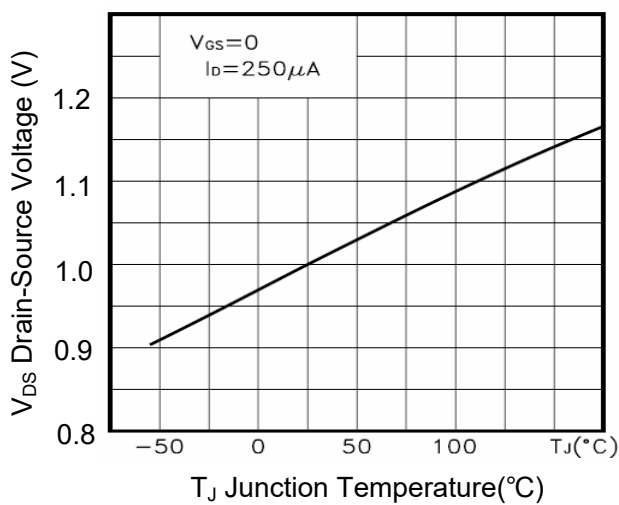
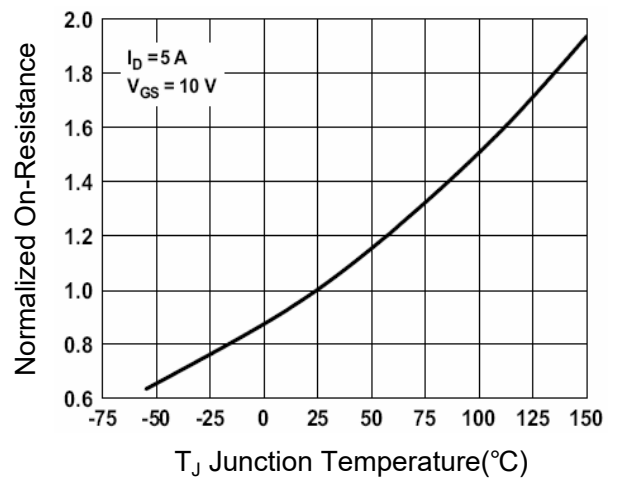
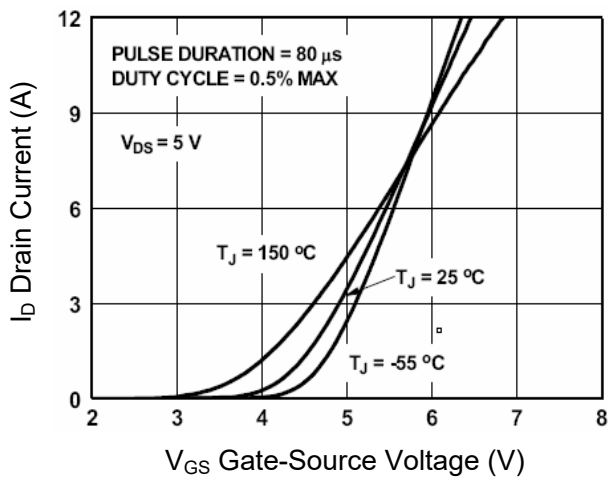
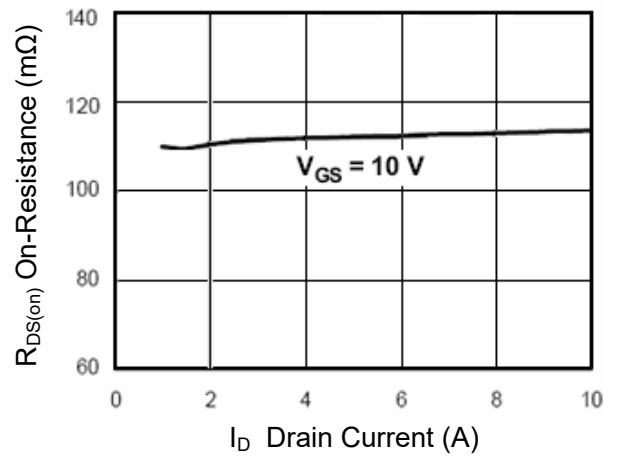
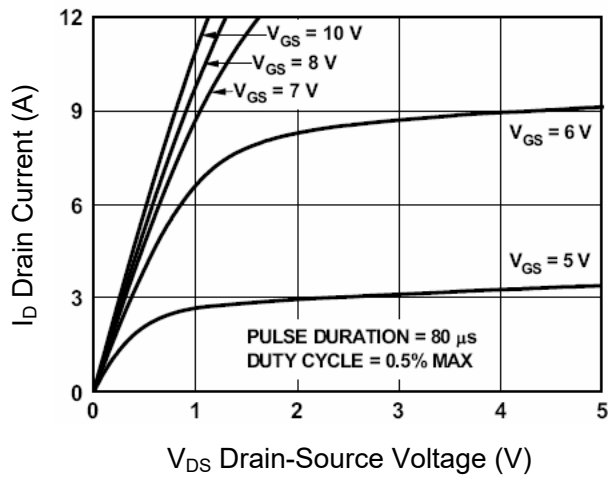

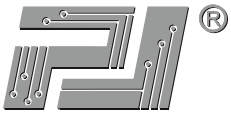

PJM10H06NSQ

N-Channel Enhancement Mode Power MOSFET

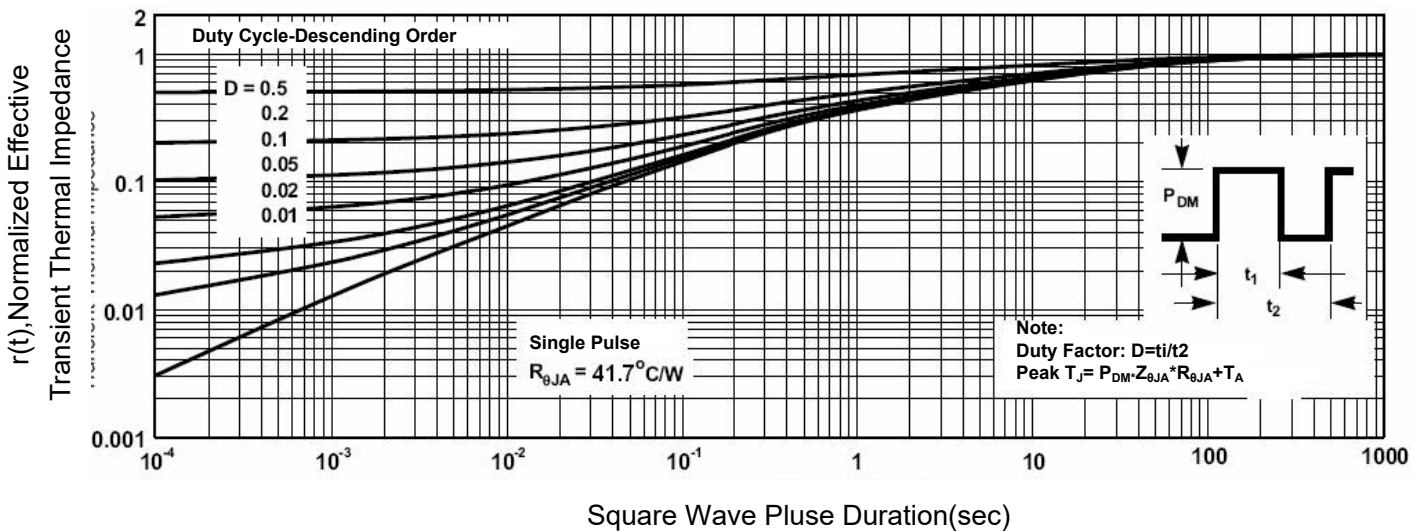
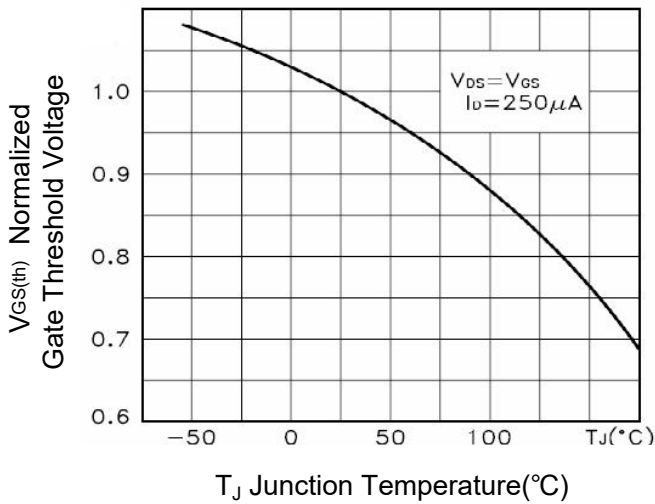
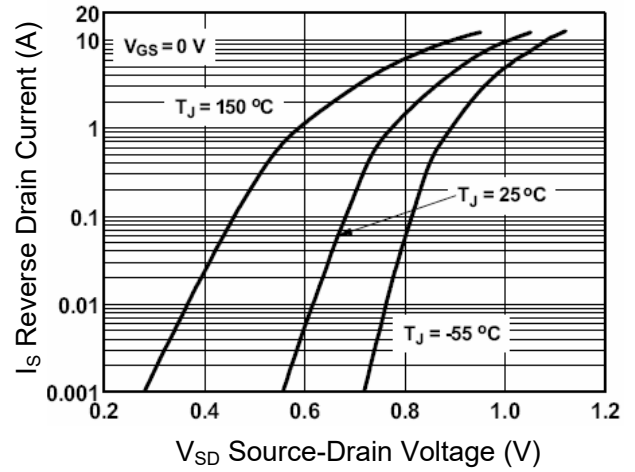
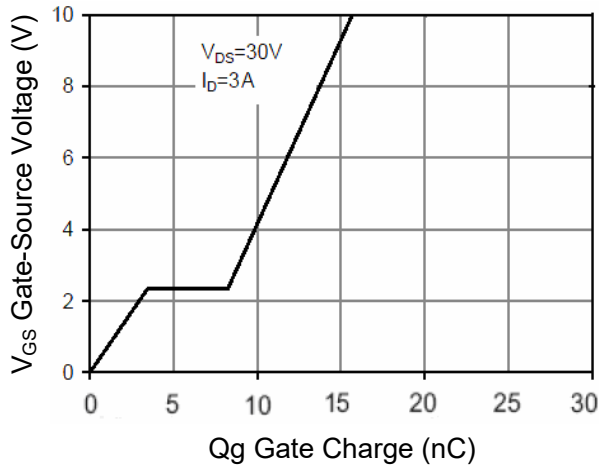



PJM10H06NSQ

N-Channel Enhancement Mode Power MOSFET

Package Outline

SOT-89

Dimensions in mm

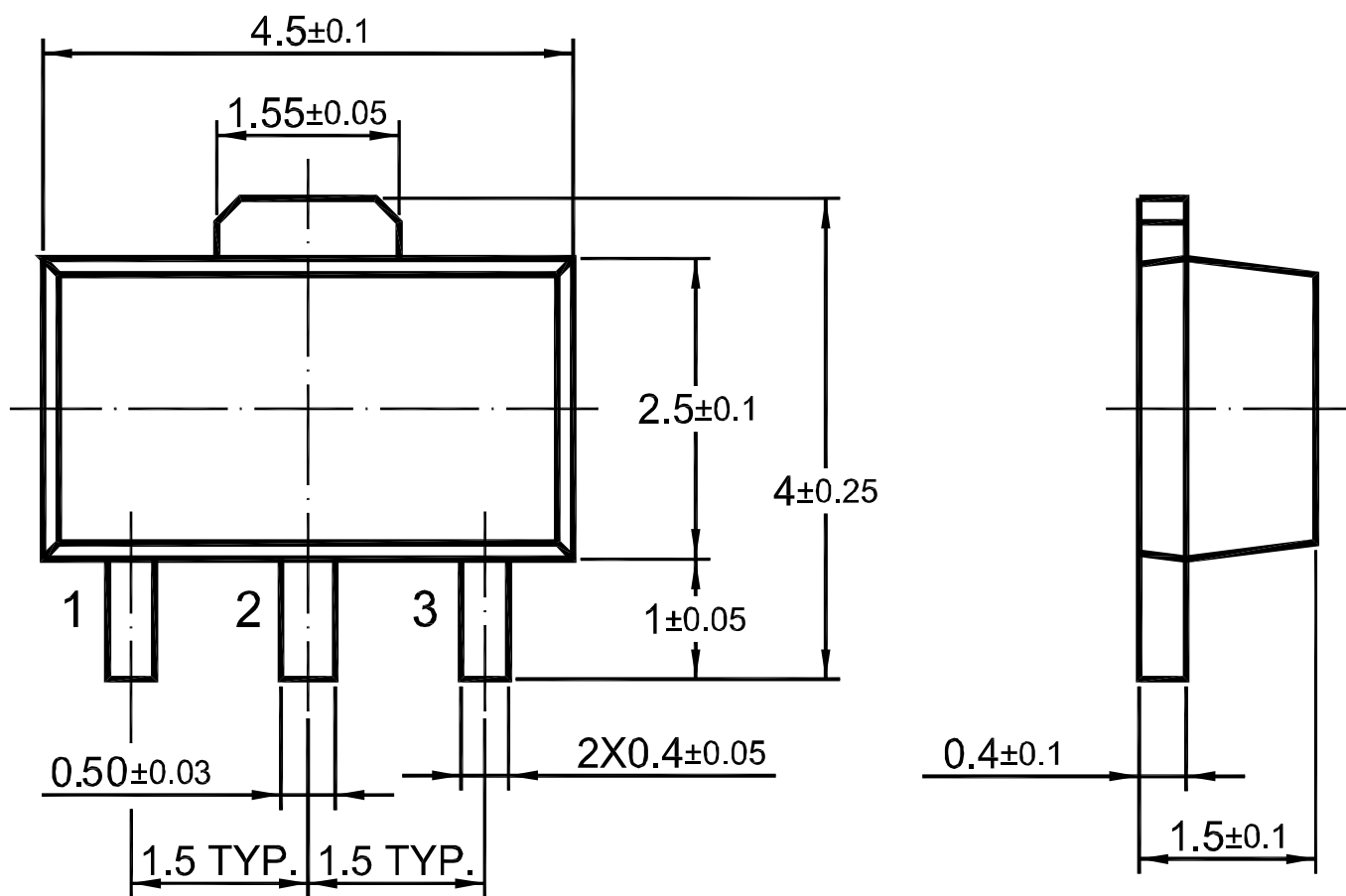

Ordering Information

Device	Package	Shipping
PJM10H06NSQ	SOT-89	1,000PCS/Reel&7inches
		3,000PCS/Reel&13inches



Conditions of Soldering and Storage

◆ Recommended condition of reflow soldering

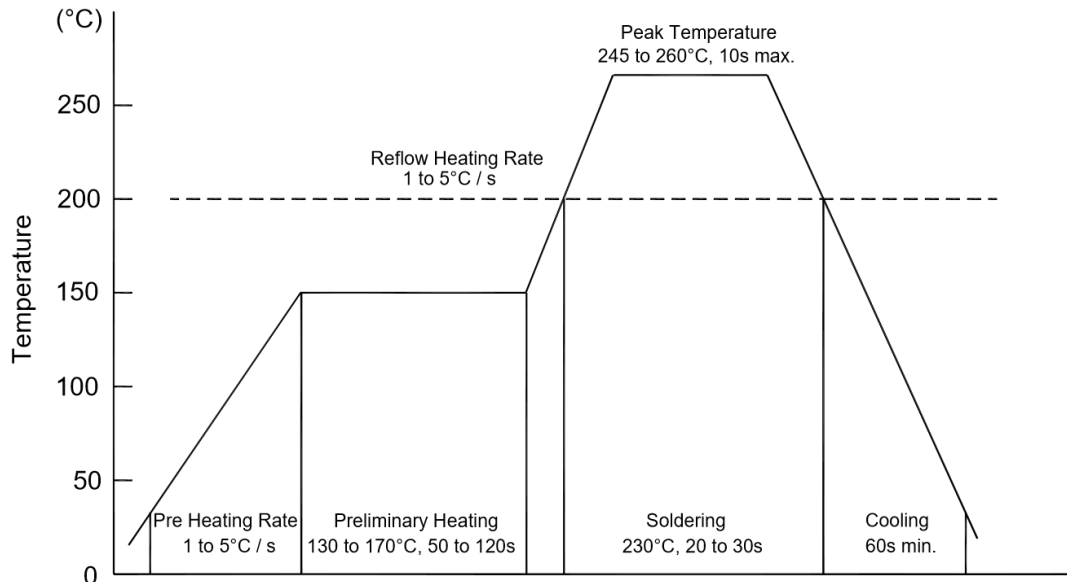

Recommended peak temperature is over 245 °C. If peak temperature is below 245 °C, you may adjust the following parameters:

- Time length of peak temperature (longer)
- Time length of soldering (longer)
- Thickness of solder paste (thicker)

◆ Conditions of hand soldering

- Temperature: 370 °C
- Time: 3s max.
- Times: one time

◆ Storage conditions

- **Temperature**
5 to 40 °C
- **Humidity**
30 to 80% RH
- **Recommended period**
One year after manufacturing



PJM10H06NSQ

N-Channel Enhancement Mode Power MOSFET

Package Specifications

- The method of packaging (1,000PCS/Reel&7inches)

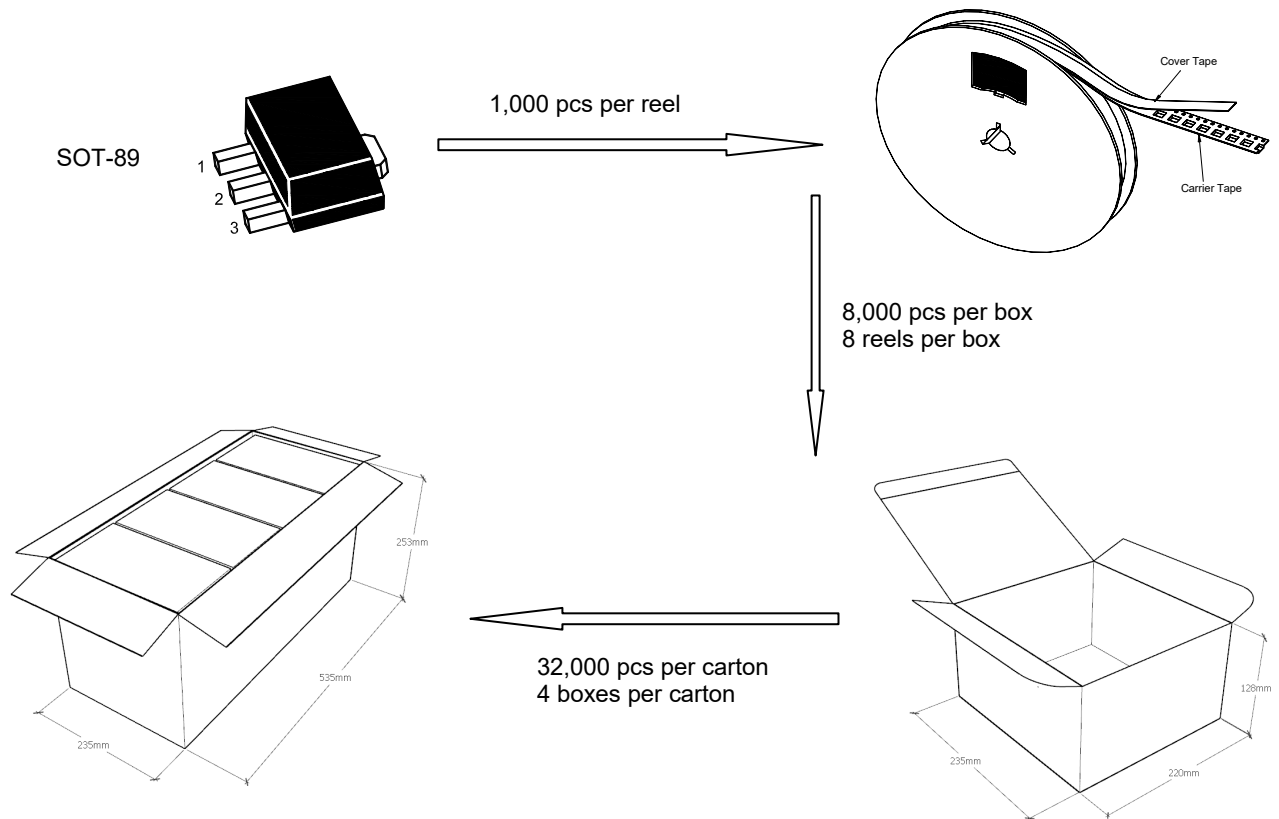

◆ Embossed tape and reel data

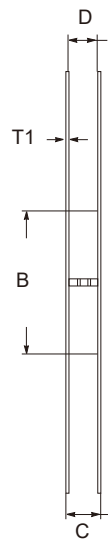
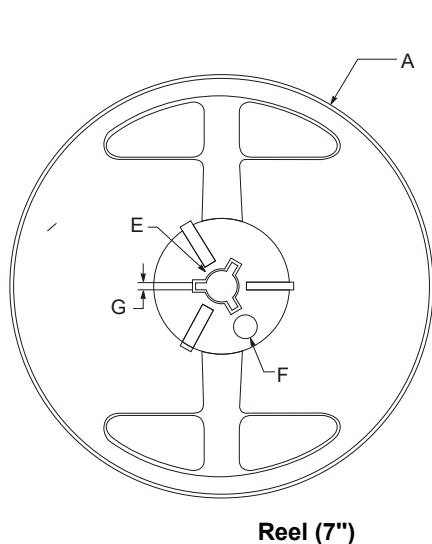

symbol	Value(unit:mm)
A	$\Phi 179 \pm 1$
B	60.5 ± 0.2
C	15.3 ± 0.3
D	12.5~13.7
E	$\Phi 13.5 \pm 0.2$
F	$\Phi 10.0 \pm 0.2$
G	2.7 ± 0.2
T1	1.0 ± 0.2

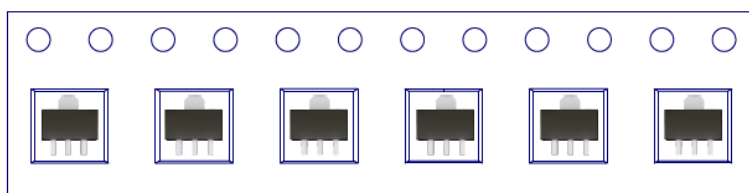



PJM10H06NSQ

N-Channel Enhancement Mode Power MOSFET

Package Specifications

- The method of packaging (3,000PCS/Reel&13inches)

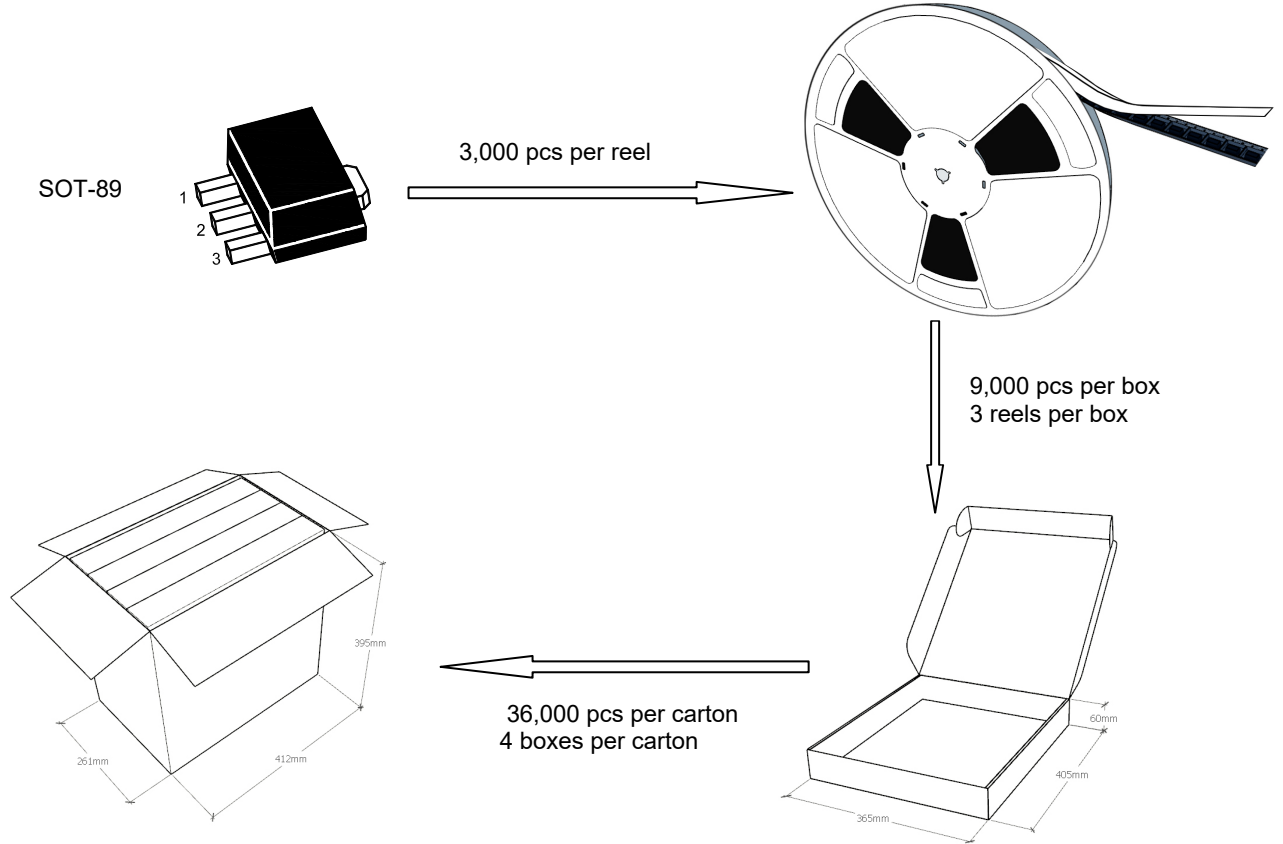

◆ Embossed tape and reel data

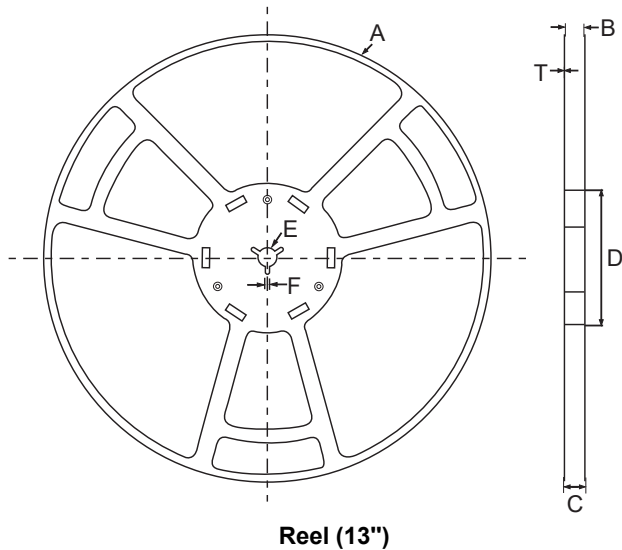

symbol	Value(unit:mm)
A	$\Phi 330 \pm 1$
B	12.7 ± 0.5
C	16.5 ± 0.3
D	$\Phi 99.5 \pm 0.5$
E	$\Phi 13.6 \pm 0.3$
F	2.8 ± 0.3
T1	1.9 ± 0.2

