



# PJM13N40PA

## N-Channel Enhancement Mode Power MOSFET

### Product Summary

- $V_{DS} = 40V, I_D = 13A$
- $R_{DS(on)} < 12.5m\Omega @ V_{GS} = 10V$
- $R_{DS(on)} < 18m\Omega @ V_{GS} = 4.5V$

### Features

- Advanced Trench Technology
- 100% Avalanche Tested
- RoHS and Reach Compliant
- Halogen and Antimony Free
- Moisture Sensitivity Level 3

### Application

- Load Switch
- PWM Applications
- Power Management

### Marking Code

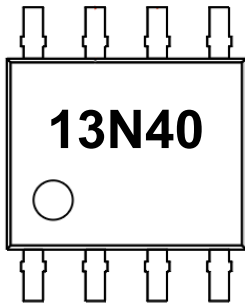

### Absolute Maximum Ratings

Ratings at 25°C ambient temperature unless otherwise specified.

Parameter	Symbol	Value	Unit
Drain-Source Voltage	$V_{DS}$	40	V
Gate-Source Voltage	$V_{GS}$	$\pm 20$	V
Drain Current-Continuous	$I_D$	13	A
Drain Current-Pulsed <sup>Note1</sup>	$I_{DM}$	52	A
Single Pulsed Avalanche Energy <sup>Note4</sup>	$E_{AS}$	33	mJ
Maximum Power Dissipation	$P_D$	3	W
Junction Temperature	$T_J$	150	°C
Storage Temperature Range	$T_{STG}$	-55 to +150	°C

### Thermal Characteristics

Thermal Resistance, Junction-to-Ambient <sup>Note2</sup>	$R_{\theta JA}$	41.6	°C/W
--	-----------------	------	------

### SOP-8

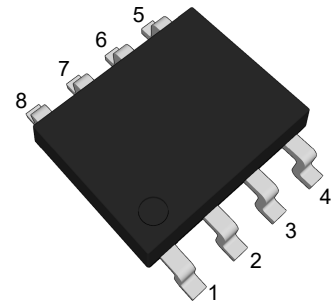

(Top View)

Pin	Description
1,2,3	Source
4	Gate
5,6,7,8	Drain

### Schematic Diagram

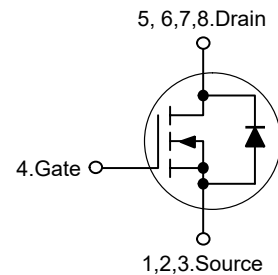



# PJM13N40PA

## N-Channel Enhancement Mode Power MOSFET

### Electrical Characteristics

( $T_J=25^{\circ}\text{C}$  unless otherwise specified)

Parameter	Symbol	Test Condition	Min.	Typ.	Max.	Unit
<b>Static Characteristics</b>						
Drain-Source Breakdown Voltage	$V_{(BR)DSS}$	$V_{GS}=0V, I_D=250\mu A$	40	--	--	V
Zero Gate Voltage Drain Current	$I_{DSS}$	$V_{DS}=40V, V_{GS}=0V$	--	--	1	$\mu A$
Gate-Body Leakage Current	$I_{GSS}$	$V_{GS}=\pm 20V, V_{DS}=0V$	--	--	$\pm 100$	nA
Gate Threshold Voltage <sup>Note3</sup>	$V_{GS(th)}$	$V_{DS}=V_{GS}, I_D=250\mu A$	1.0	1.4	2.5	V
Drain-Source On-Resistance <sup>Note3</sup>	$R_{DS(on)}$	$V_{GS}=10V, I_D=13A$	--	9	12.5	m $\Omega$
		$V_{GS}=4.5V, I_D=10A$	--	11	18	m $\Omega$
Forward Transconductance <sup>Note3</sup>	$g_{FS}$	$V_{DS}=5V, I_D=2A$	--	10	--	S
<b>Dynamic Characteristics</b>						
Input Capacitance	$C_{iss}$	$V_{DS}=15V, V_{GS}=0V, f=1\text{MHz}$	--	1625	--	pF
Output Capacitance	$C_{oss}$		--	139	--	pF
Reverse Transfer Capacitance	$C_{rss}$		--	116	--	pF
Gate Resistance	$R_g$	$V_{DS}=0V, V_{GS}=0V, f=1\text{MHz}$	--	2.1	--	$\Omega$
Total Gate Charge	$Q_g$	$V_{DS}=20V, I_D=10A, V_{GS}=10V$	--	37	--	nC
Gate-Source Charge	$Q_{gs}$		--	6	--	nC
Gate-Drain Charge	$Q_{gd}$		--	7	--	nC
<b>Switching Characteristics</b>						
Turn-on Delay Time	$t_{d(on)}$	$V_{DD}=20V, I_D=10A, R_L=1\Omega,$ $V_{GS}=10V, R_{GEN}=3\Omega$	--	12	--	nS
Turn-on Rise Time	$t_r$		--	12	--	nS
Turn-off Delay Time	$t_{d(off)}$		--	38	--	nS
Turn-off Fall Time	$t_f$		--	9	--	nS
<b>Source-Drain Diode Characteristics</b>						
Diode Forward Voltage <sup>Note3</sup>	$V_{SD}$	$V_{GS}=0V, I_S=8A$	--	0.8	1.2	V
Diode Forward Current <sup>Note2</sup>	$I_S$		--	--	13	A

- Note: 1. Repetitive Rating: Pulse width limited by maximum junction temperature.  
2. Surface Mounted on FR4 Board,  $t \leq 10$  sec.  
3. Pulse Test: Pulse width  $\leq 300\mu s$ , duty cycles  $\leq 2\%$ .  
4. The test condition is  $V_{DD}=30V, V_{GS}=10V, L=0.5mH, I_{AS}=11.6A, R_G=25\Omega, T_J=25^{\circ}\text{C}$ .



# PJM13N40PA

## N-Channel Enhancement Mode Power MOSFET

### Typical Characteristic Curves

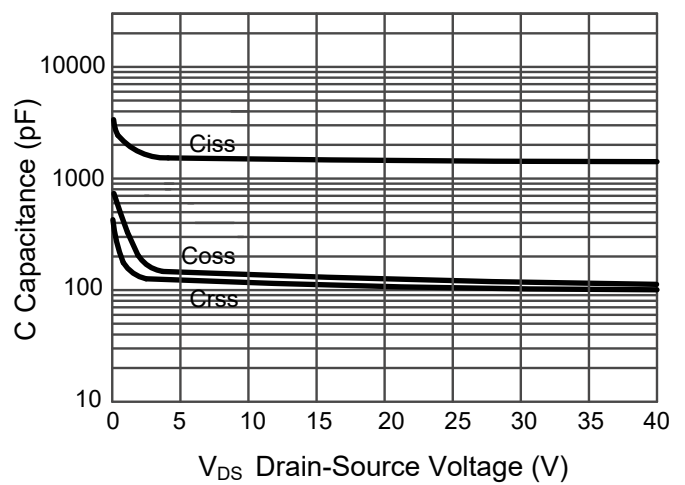
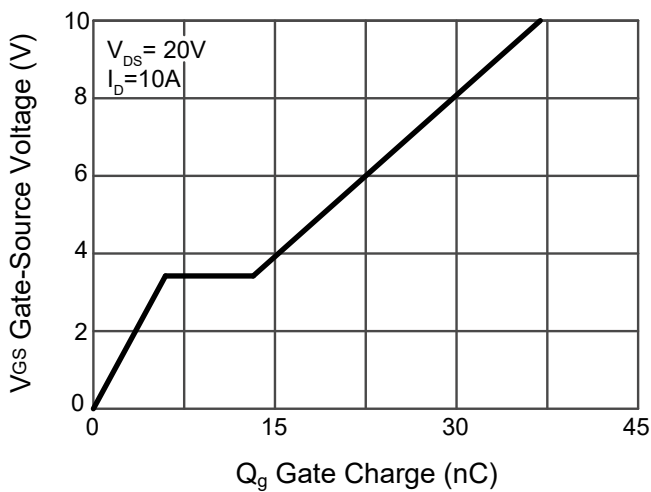
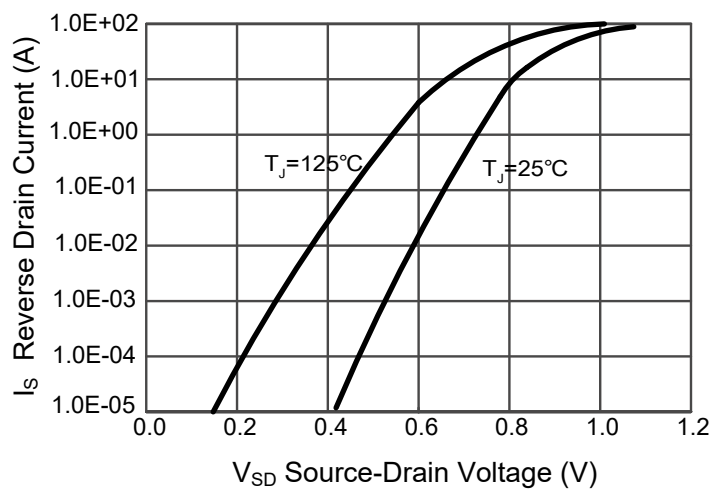
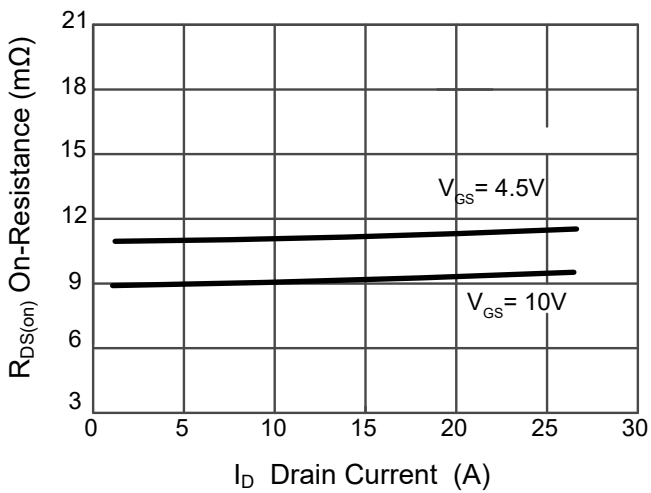
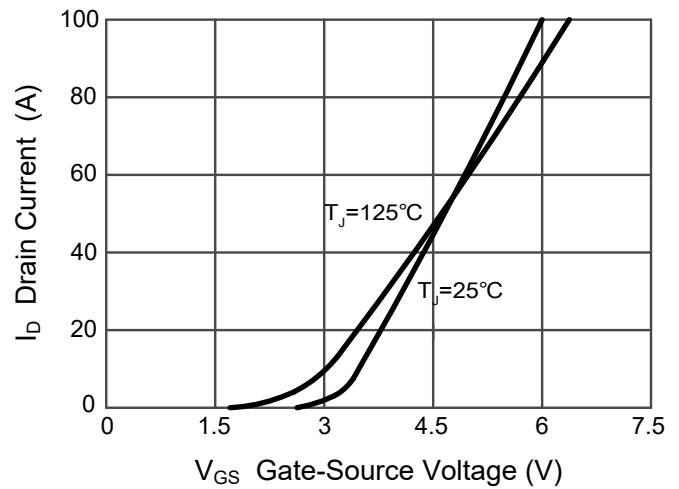
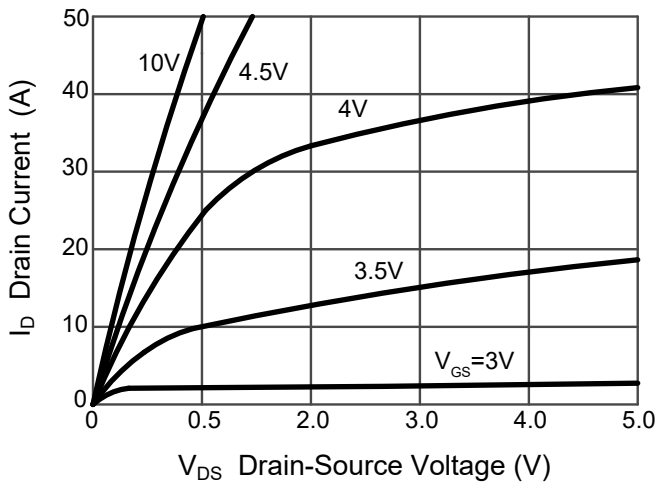



# PJM13N40PA

## N-Channel Enhancement Mode Power MOSFET

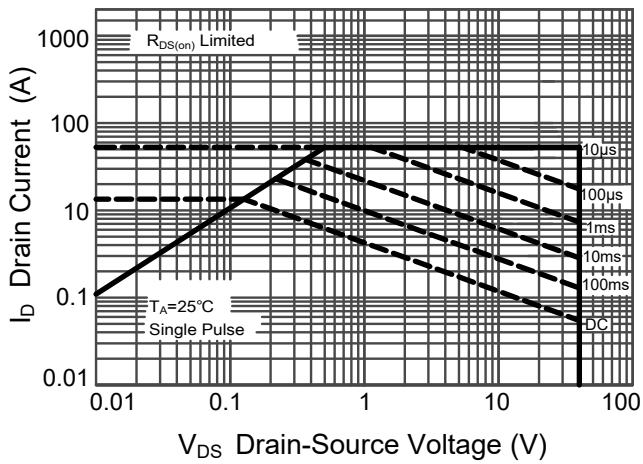
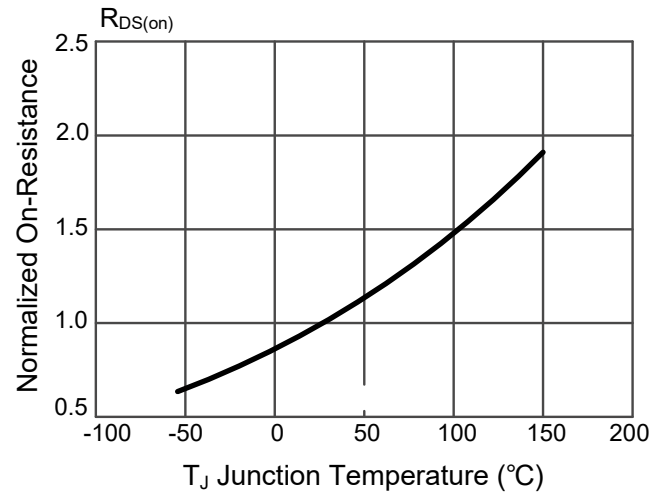
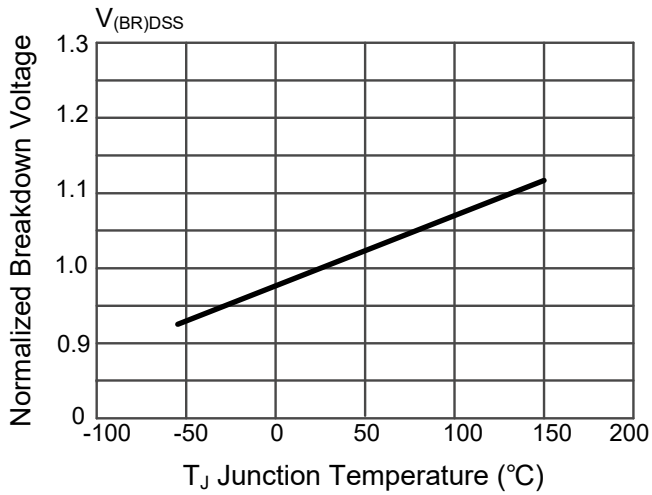



# PJM13N40PA

## N-Channel Enhancement Mode Power MOSFET

### Package Outline

SOP-8

Dimensions in mm

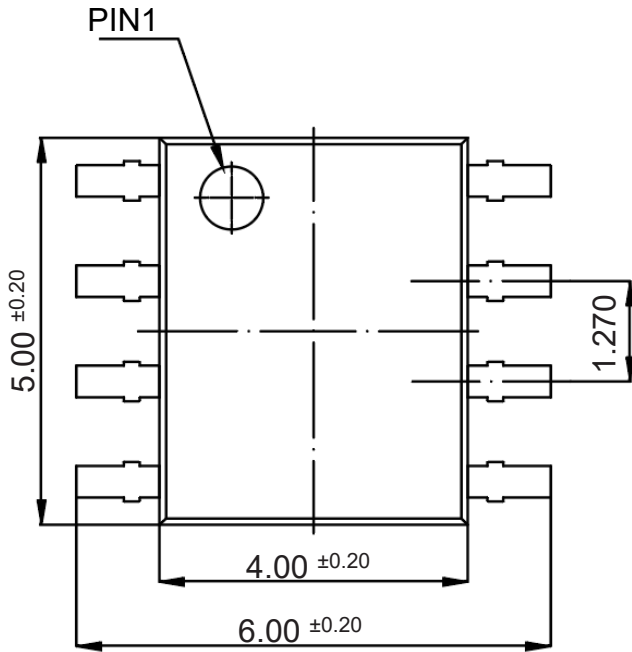

TOP VIEW

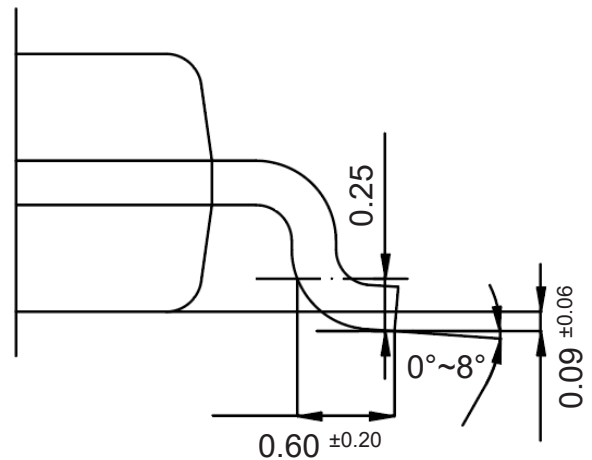

DETAIL A

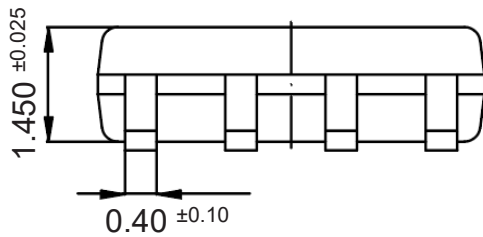

SIDE VIEW

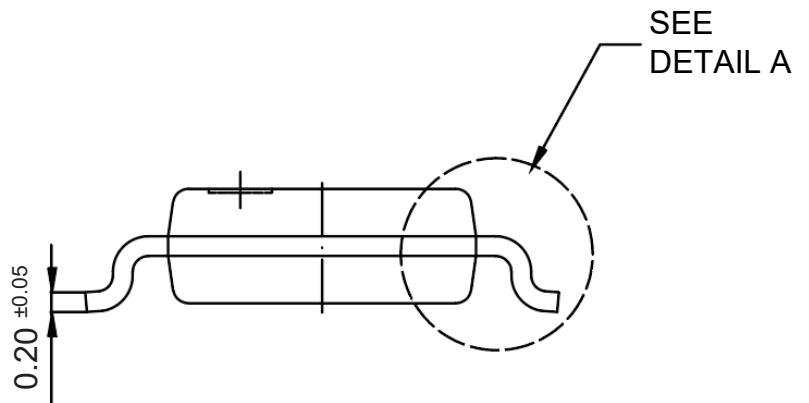

FRONT VIEW

### Ordering Information

Device	Package	Shipping
PJM13N40PA	SOP-8	4,000PCS/Reel&13inches



### Conditions of Soldering and Storage

#### ◆ Recommended condition of reflow soldering

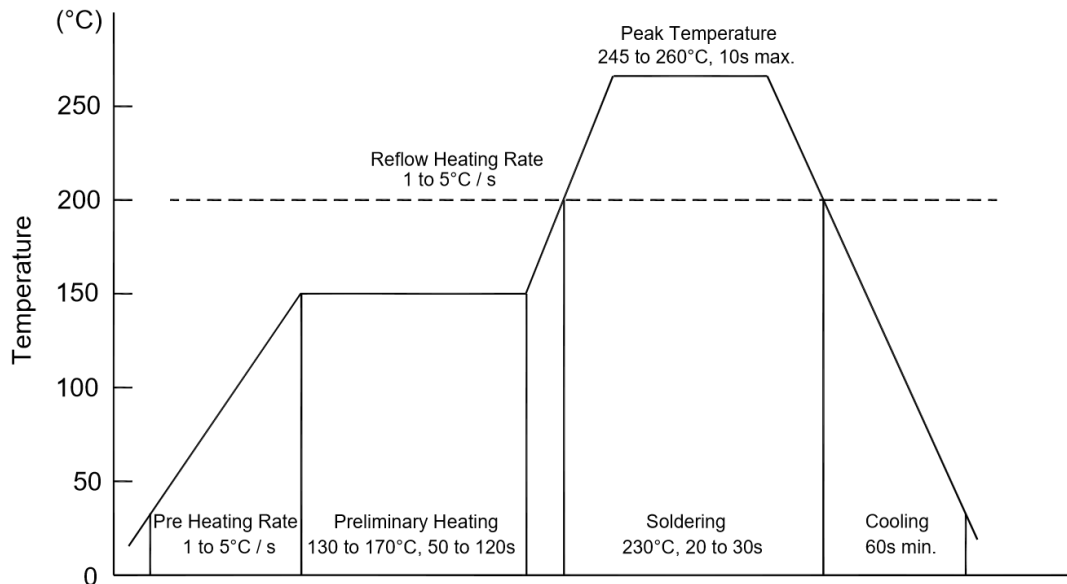

Recommended peak temperature is over 245°C. If peak temperature is below 245°C, you may adjust the following parameters:

- Time length of peak temperature (longer)
- Time length of soldering (longer)
- Thickness of solder paste (thicker)

#### ◆ Conditions of hand soldering

- Temperature: 300°C
- Time: 3s max.
- Times: one time

#### ◆ Storage conditions

- **Temperature**  
5 to 40°C
- **Humidity**  
30 to 80% RH
- **Recommended period**  
One year after manufacturing



# PJM13N40PA

## N-Channel Enhancement Mode Power MOSFET

### Package Specifications

- The method of packaging

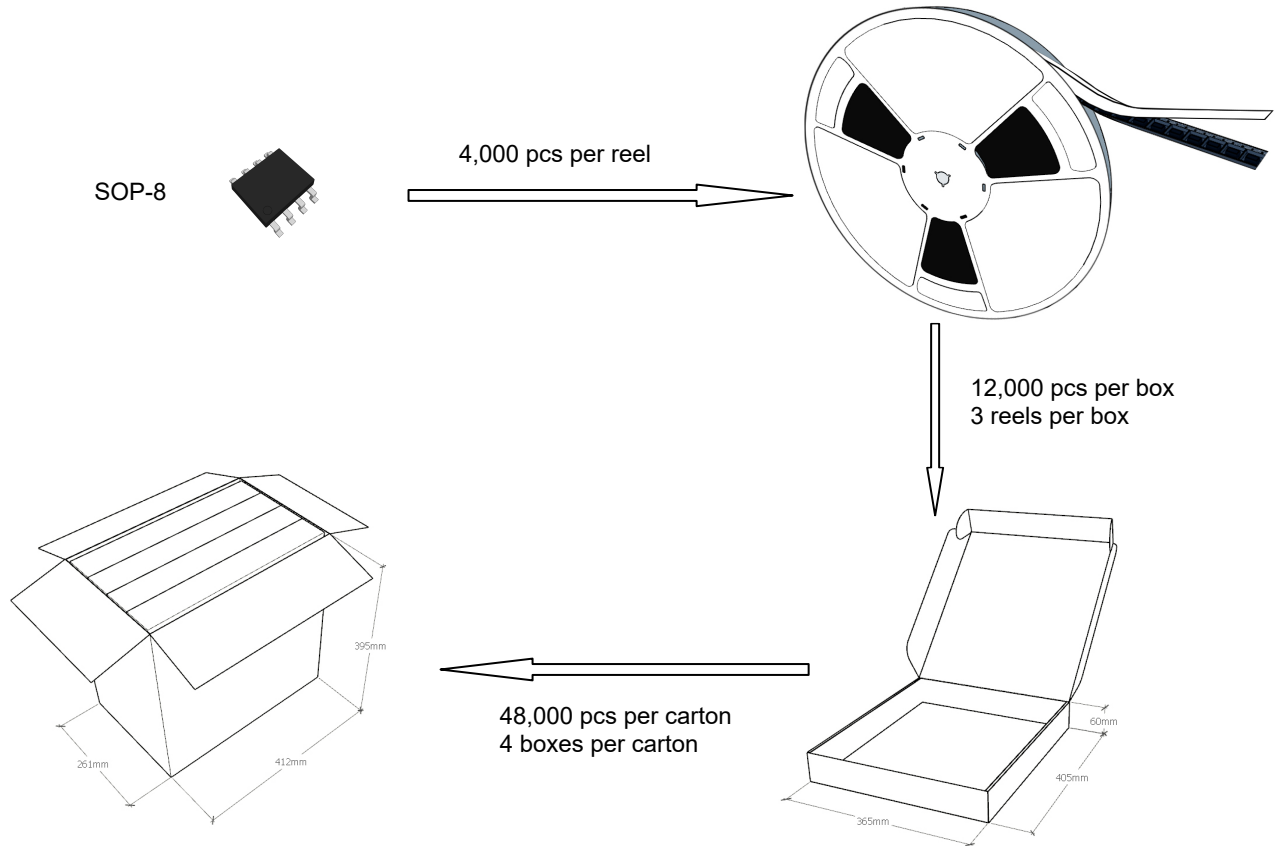

### ◆ Embossed tape and reel data

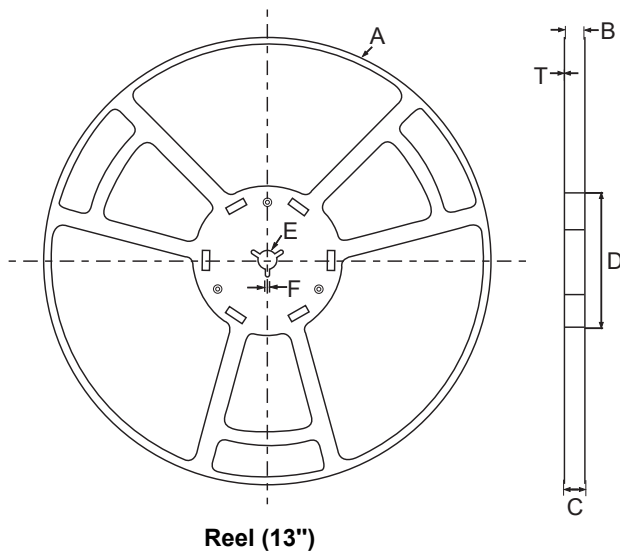

symbol	Value(unit:mm)
A	$\phi 330 \pm 1$
B	$12.7 \pm 0.5$
C	$16.5 \pm 0.3$
D	$\phi 99.5 \pm 0.5$
E	$\phi 13.6 \pm 0.3$
F	$2.8 \pm 0.3$
T	$1.9 \pm 0.2$

