



PJM2035PSA

P-Channel Enhancement Mode Power MOSFET

Features

- Low gate charge and $R_{DS(on)}$
- ESD protected(HBM) up to 2KV
- $V_{DS} = -20V, I_D = -4.9A$
 $R_{DS(on)} < 35m\Omega @ V_{GS} = -4.5V$

SOT-23

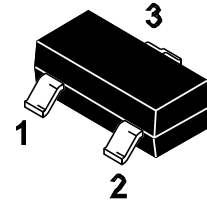

1. Gate 2. Source 3. Drain

Marking Code: 2035K

Applications

- PWM applications
- Load switch
- Power management

Schematic Diagram

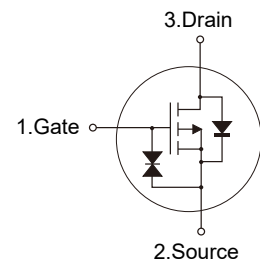

Absolute Maximum Ratings

Ratings at 25°C ambient temperature unless otherwise specified.

Parameter	Symbol	Value	Unit
Drain-Source Voltage	$-V_{DS}$	20	V
Gate-Source Voltage	V_{GS}	± 10	V
Drain Current-Continuous	$-I_D$	4.9	A
Maximum Power Dissipation	P_D	0.9	W
Junction Temperature	T_J	150	°C
Storage Temperature Range	T_{STG}	-55 to +150	°C

Thermal Characteristics

Thermal Resistance, Junction-to-Ambient ^{Note2}	$R_{\theta JA}$	139	°C/W
--	-----------------	-----	------



PJM2035PSA

P-Channel Enhancement Mode Power MOSFET

Electrical Characteristics

(Ta=25°C unless otherwise specified)

Parameter	Symbol	Test Condition	Min.	Typ.	Max.	Unit
Static Characteristics						
Drain-Source Breakdown Voltage	$-V_{(BR)DSS}$	$V_{GS}=0V, I_D=-250\mu A$	20	--	--	V
Zero Gate Voltage Drain Current	$-I_{DSS}$	$V_{DS}=-20V, V_{GS}=0V$	--	--	1	μA
Gate-Body Leakage Current	I_{GSS}	$V_{GS}=\pm 8V, V_{DS}=0V$	--	--	± 10	μA
Gate Threshold Voltage ^{Note3}	$-V_{GS(th)}$	$V_{DS}=V_{GS}, I_D=-250\mu A$	0.4	0.7	1	V
Drain-Source On-Resistance ^{Note3}	$R_{DS(on)}$	$V_{GS}=-4.5V, I_D=-4A$	--	--	35	m Ω
		$V_{GS}=-2.5V, I_D=-4A$	--	--	45	m Ω
		$V_{GS}=-1.8V, I_D=-2A$	--	--	62	m Ω
Forward Transconductance ^{Note3}	g_{FS}	$V_{DS}=-5V, I_D=-4A$	--	14	--	S
Dynamic Characteristics						
Input Capacitance	C_{iss}	$V_{DS}=-10V, V_{GS}=0V, f=1MHz$	--	1610	--	pF
Output Capacitance	C_{oss}		--	157	--	pF
Reverse Transfer Capacitance	C_{rss}		--	145	--	pF
Switching Characteristics						
Turn-on Delay Time	$t_{d(on)}$	$V_{DS}=-10V, I_D=-1A,$ $V_{GS}=-4.5V, R_G=6\Omega, R_L=10\Omega$	--	16.8	--	nS
Turn-on Rise Time	t_r		--	12.4	--	nS
Turn-off Delay Time	$t_{d(off)}$		--	94.1	--	nS
Turn-off Fall Time	t_f		--	42.4	--	nS
Total Gate Charge	Q_g	$V_{DS}=-10V, I_D=-4A, V_{GS}=-4.5V$	--	15.4	--	nC
Gate-Source Charge	Q_{gs}		--	2.5	--	nC
Gate-Drain Charge	Q_{gd}		--	3.3	--	nC
Source-Drain Diode Characteristics						
Diode Forward Voltage ^{Note3}	$-V_{SD}$	$V_{GS}=0V, I_S=-1A$	--	--	1	V
Diode Forward Current ^{Note2}	$-I_S$		--	--	4.9	A

Note: 1. Repetitive Rating: Pulse width limited by maximum junction temperature.

2. Surface Mounted on FR4 Board, $t \leq 10$ sec.

3. Pulse Test: Pulse width $\leq 300\mu s$, duty cycle $\leq 2\%$.



Typical Characteristic Curves

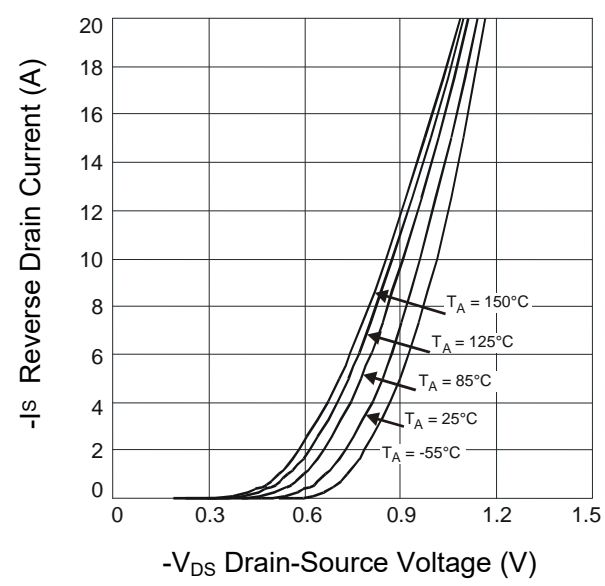
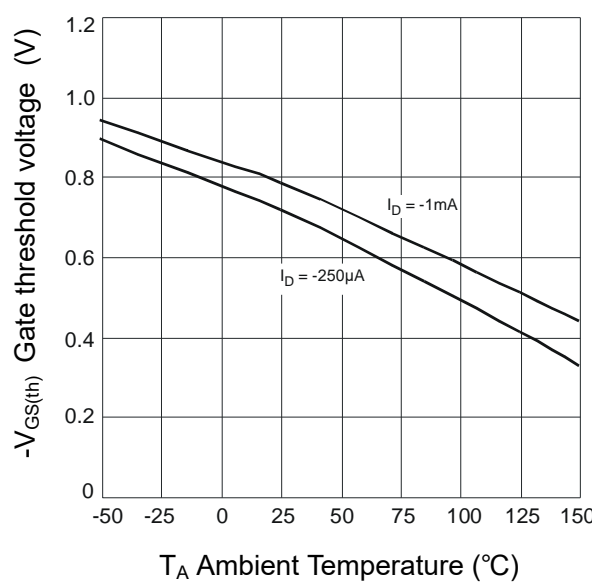
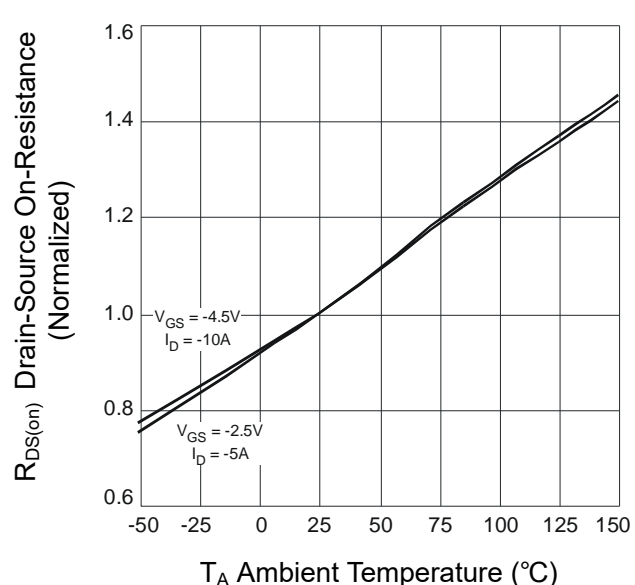
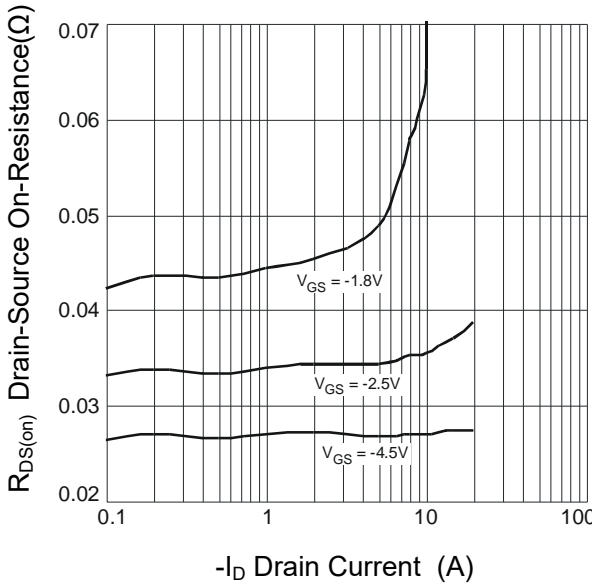
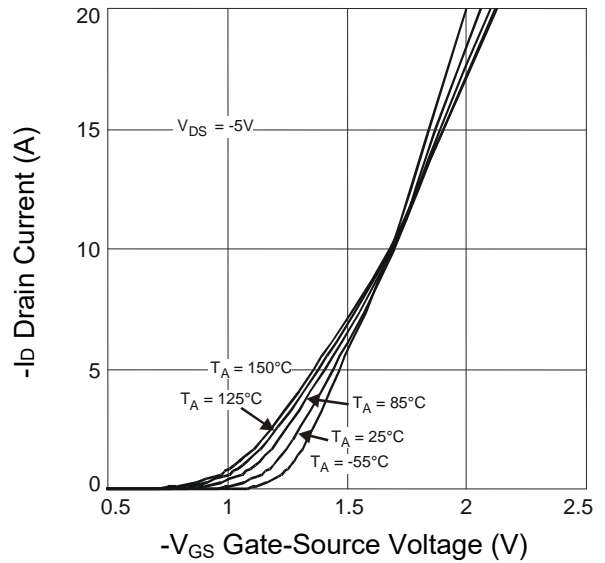
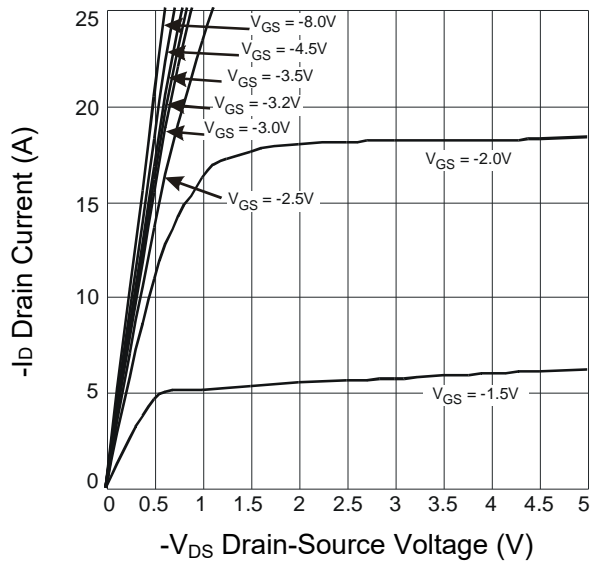



PJM2035PSA P-Channel Enhancement Mode Power MOSFET

Package Outline

SOT-23

Dimensions in mm

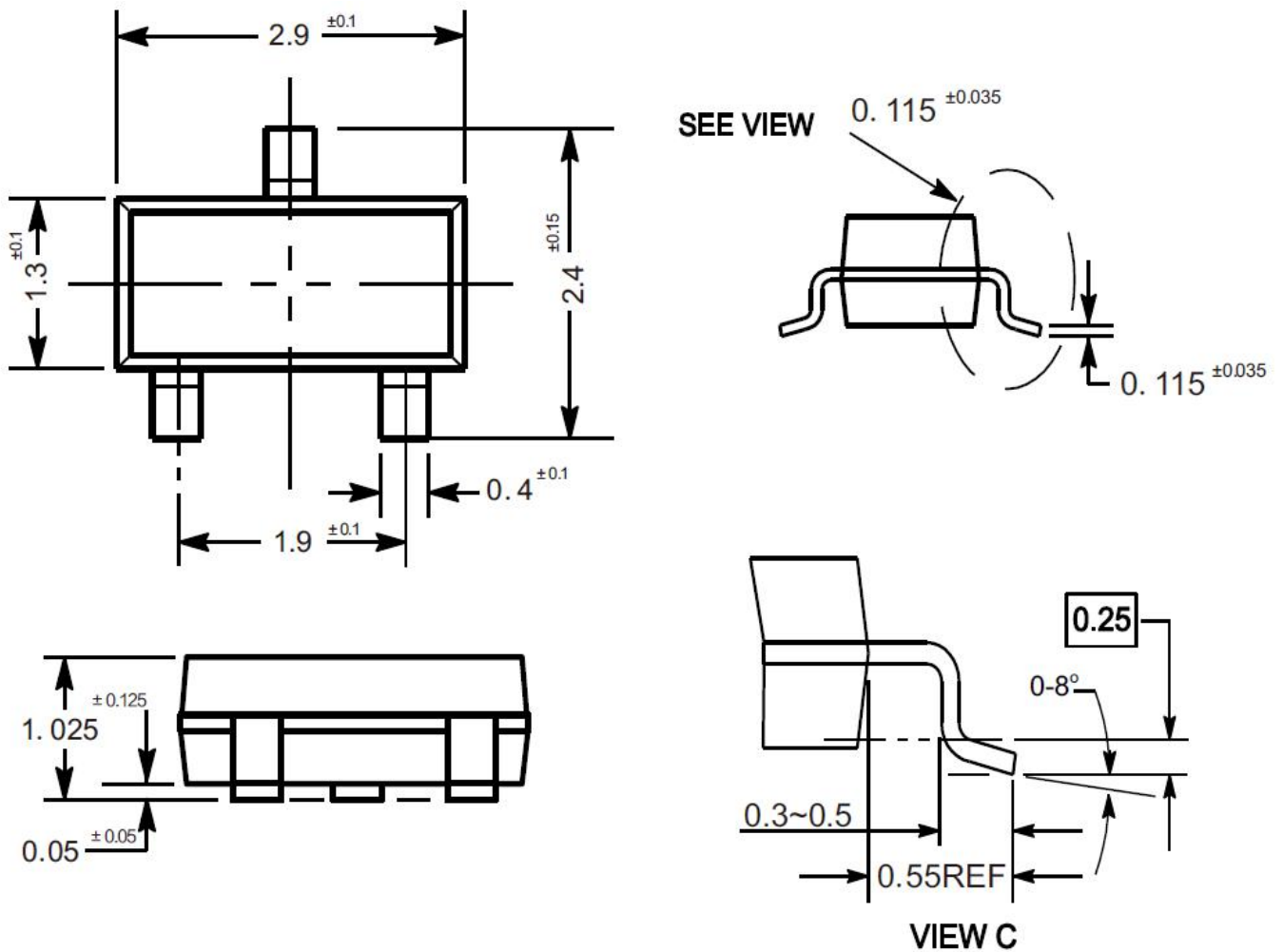

Ordering Information

Device	Package	Shipping
PJM2035PSA	SOT-23	3,000PCS/Reel&7inches



Conditions of Soldering and Storage

◆ Recommended condition of reflow soldering

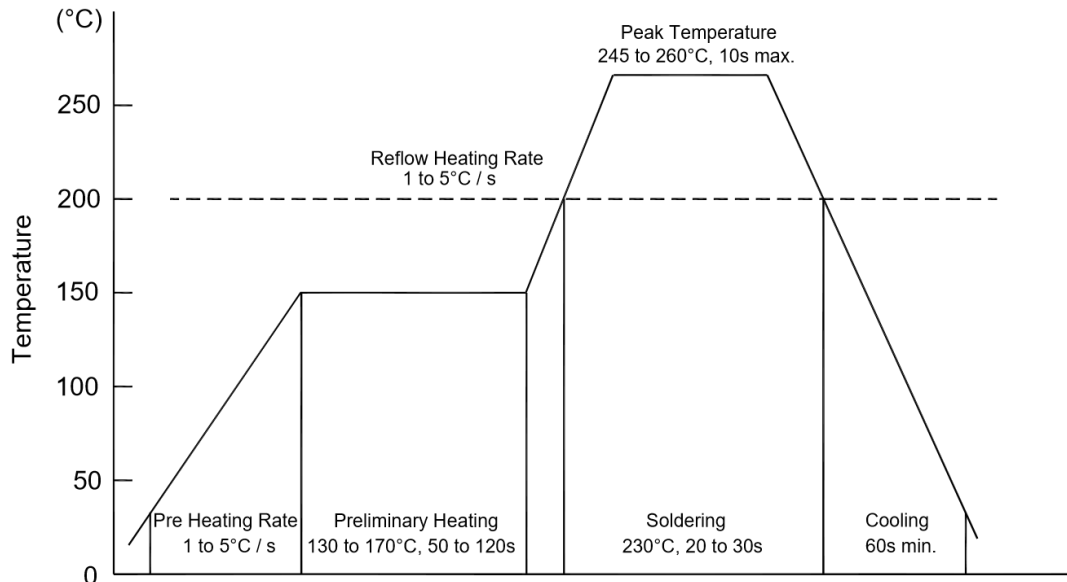

Recommended peak temperature is over 245 °C. If peak temperature is below 245 °C, you may adjust the following parameters:

- Time length of peak temperature (longer)
- Time length of soldering (longer)
- Thickness of solder paste (thicker)

◆ Conditions of hand soldering

- Temperature: 370 °C
- Time: 3s max.
- Times: one time

◆ Storage conditions

- **Temperature**
5 to 40 °C
- **Humidity**
30 to 80% RH
- **Recommended period**
One year after manufacturing

Package Specifications

- The method of packaging

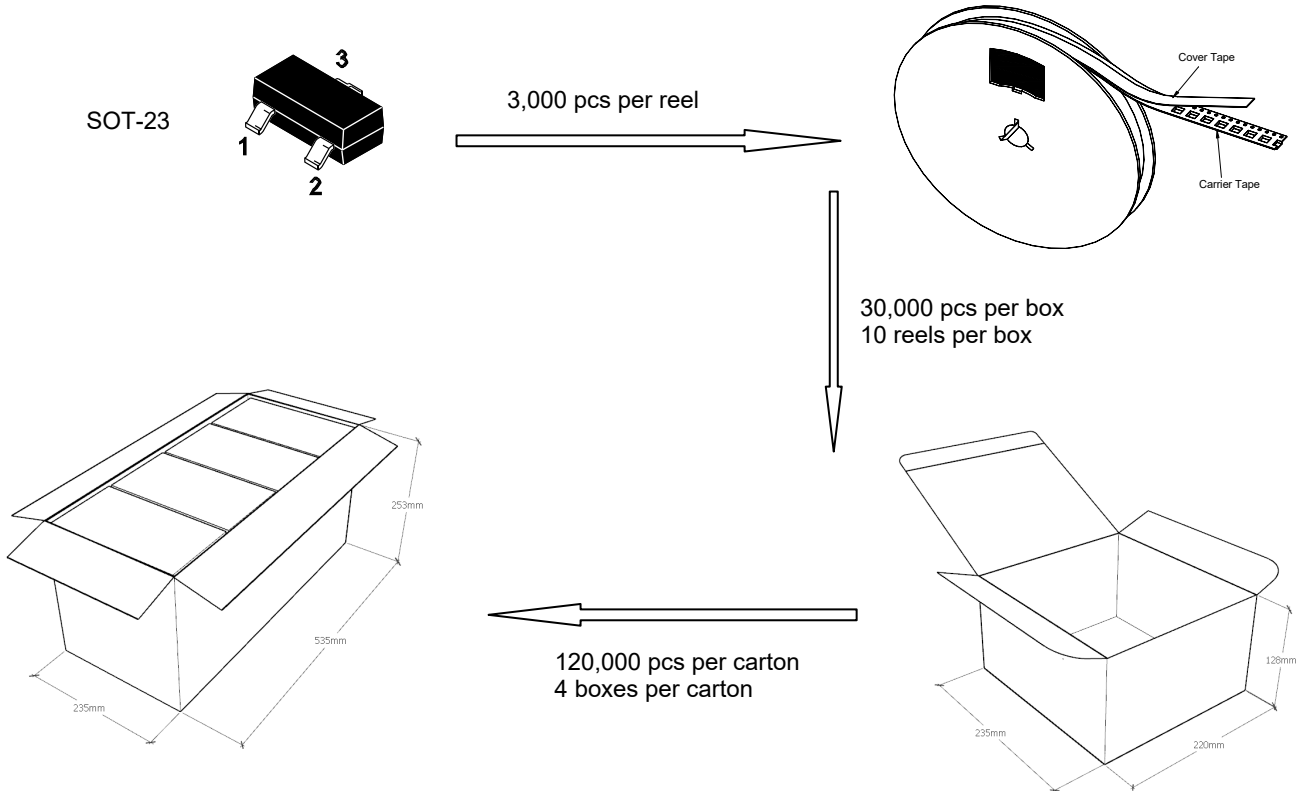

◆ Embossed tape and reel data

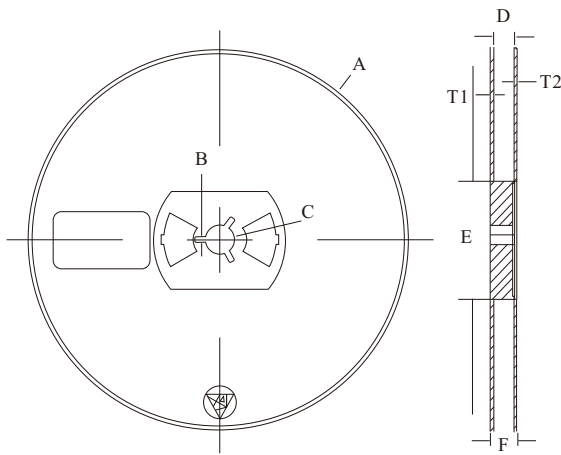

Symbol	Value (unit: mm)
A	Ø 177.8±1
B	2.7±0.2
C	Ø 13.5±0.2
E	Ø 54.5±0.2
F	12.3±0.3
D	9.6+2/-0.3
T1	1.0±0.2
T2	1.2±0.2

Reel (7")

