



PJM2324NSA

N-Channel Enhancement Mode Power MOSFET

Features

- Trench FET Power MOSFET
- $V_{DS}= 100V, I_D= 2A$
 $R_{DS(on)} < 234m\Omega @ V_{GS}= 10V$

SOT-23

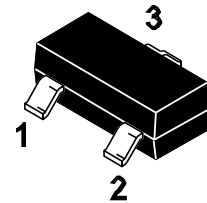

1. Gate 2. Source 3. Drain

Marking Code: S24

Applications

- DC/DC Converter
- Battery switch

Schematic Diagram

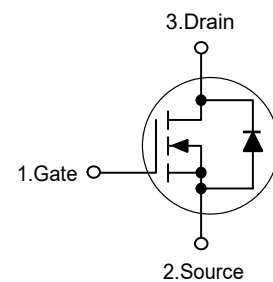

Absolute Maximum Ratings

Ratings at 25°C ambient temperature unless otherwise specified.

Parameter	Symbol	Value	Unit
Drain-Source Voltage	V_{DS}	100	V
Gate-Source Voltage	V_{GS}	± 20	V
Drain Current-Continuous	I_D	2	A
Drain Current-Pulsed ^{Note1}	I_{DM}	8	A
Maximum Power Dissipation	P_D	0.35	W
Junction Temperature	T_J	150	°C
Storage Temperature Range	T_{STG}	-55 to +150	°C

Thermal Characteristics

Thermal Resistance, Junction-to-Ambient ^{Note2}	$R_{\theta JA}$	357	°C/W
--	-----------------	-----	------



PJM2324NSA

N-Channel Enhancement Mode Power MOSFET

Electrical Characteristics

(Ta=25°C unless otherwise specified)

Parameter	Symbol	Test Condition	Min.	Typ.	Max.	Unit
Static Characteristics						
Drain-Source Breakdown Voltage	$V_{(BR)DSS}$	$V_{GS}=0V, I_D=250\mu A$	100	--	--	V
Zero Gate Voltage Drain Current	I_{DSS}	$V_{DS}=100V, V_{GS}=0V$	--	--	1	μA
Gate-Body Leakage Current	I_{GSS}	$V_{GS}=\pm 20V, V_{DS}=0V$	--	--	± 100	nA
Gate Threshold Voltage ^{Note3}	$V_{GS(th)}$	$V_{DS}=V_{GS}, I_D=250\mu A$	1.2	--	2.8	V
Drain-Source On-Resistance ^{Note3}	$R_{DS(on)}$	$V_{GS}=10V, I_D=1.5A$	--	--	234	m Ω
		$V_{GS}=4.5V, I_D=0.5A$	--	--	278	m Ω
Forward Transconductance ^{Note3}	g_{FS}	$V_{DS}=20V, I_D=1.5A$	--	2	--	S
Dynamic Characteristics						
Input Capacitance	C_{iss}	$V_{DS}=50V, V_{GS}=0V, f=1MHz$	--	190	--	pF
Output Capacitance	C_{oss}		--	22	--	pF
Reverse Transfer Capacitance	C_{rss}		--	13	--	pF
Switching Characteristics						
Turn-on Delay Time	$t_{d(on)}$	$V_{DD}=50V, V_{GEN}=4.5V$ $I_D=1.3A, R_L=39\Omega, R_G=1\Omega$	--	--	45	nS
Turn-on Rise Time	t_r		--	--	39	nS
Turn-off Delay Time	$t_{d(off)}$		--	--	26	nS
Turn-off Fall Time	t_f		--	--	20	nS
Total Gate Charge	Q_g	$V_{DS}=50V, V_{GS}=4.5V$ $I_D=1.6A$	--	--	5.8	nC
Gate-Source Charge	Q_{gs}		--	0.75	--	nC
Gate-Drain Charge	Q_{gd}		--	1.4	--	nC
Source-Drain Diode Characteristics						
Diode Forward Voltage ^{Note3}	V_{SD}	$V_{GS}=0V, I_S=1.3A$	--	--	1.2	V
Diode Forward Current ^{Note2}	I_S		--	--	2	A

Note: 1. Repetitive Rating: Pulse width limited by maximum junction temperature.
 2. Surface Mounted on FR4 Board, $t \leq 10$ sec.
 3. Pulse Test: Pulse width $\leq 300\mu s$, duty cycle $\leq 0.5\%$.



PJM2324NSA

N-Channel Enhancement Mode Power MOSFET

Typical Characteristic Curves

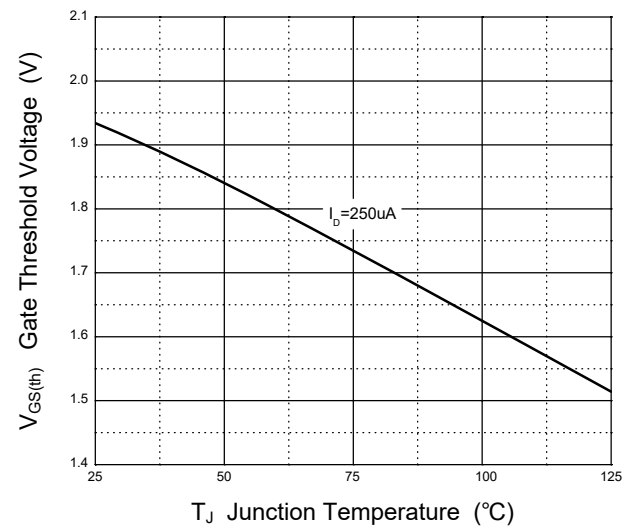
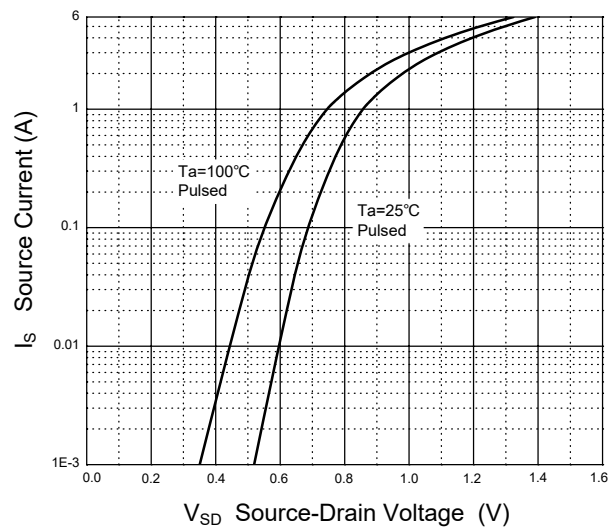
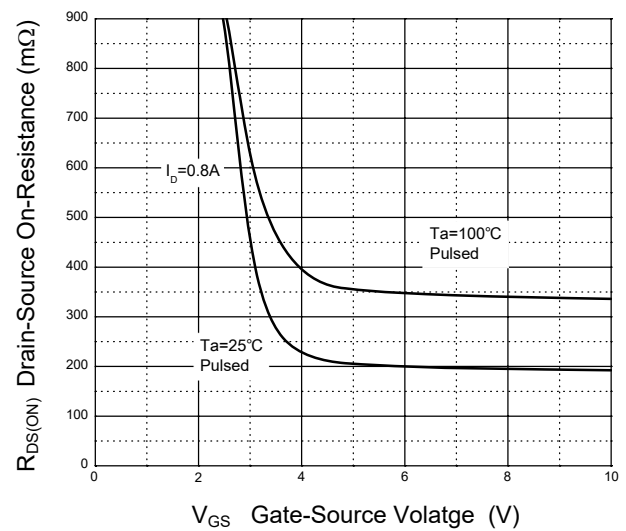
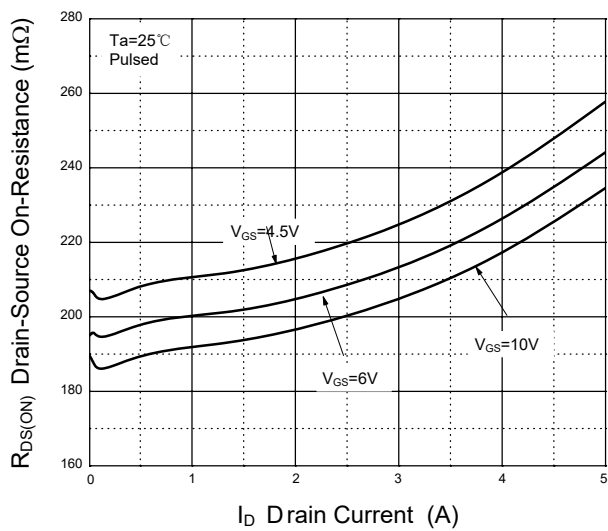
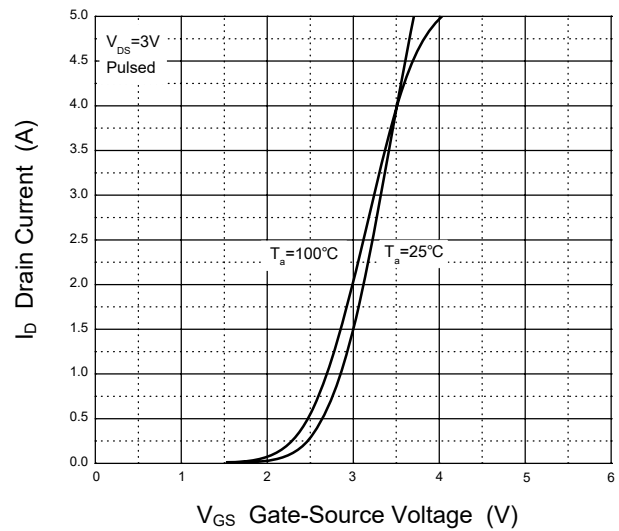
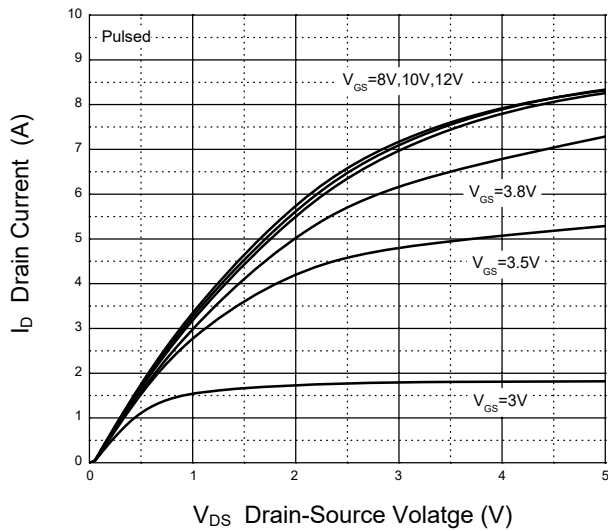



PJM2324NSA

N-Channel Enhancement Mode Power MOSFET

Package Outline

SOT-23

Dimensions in mm

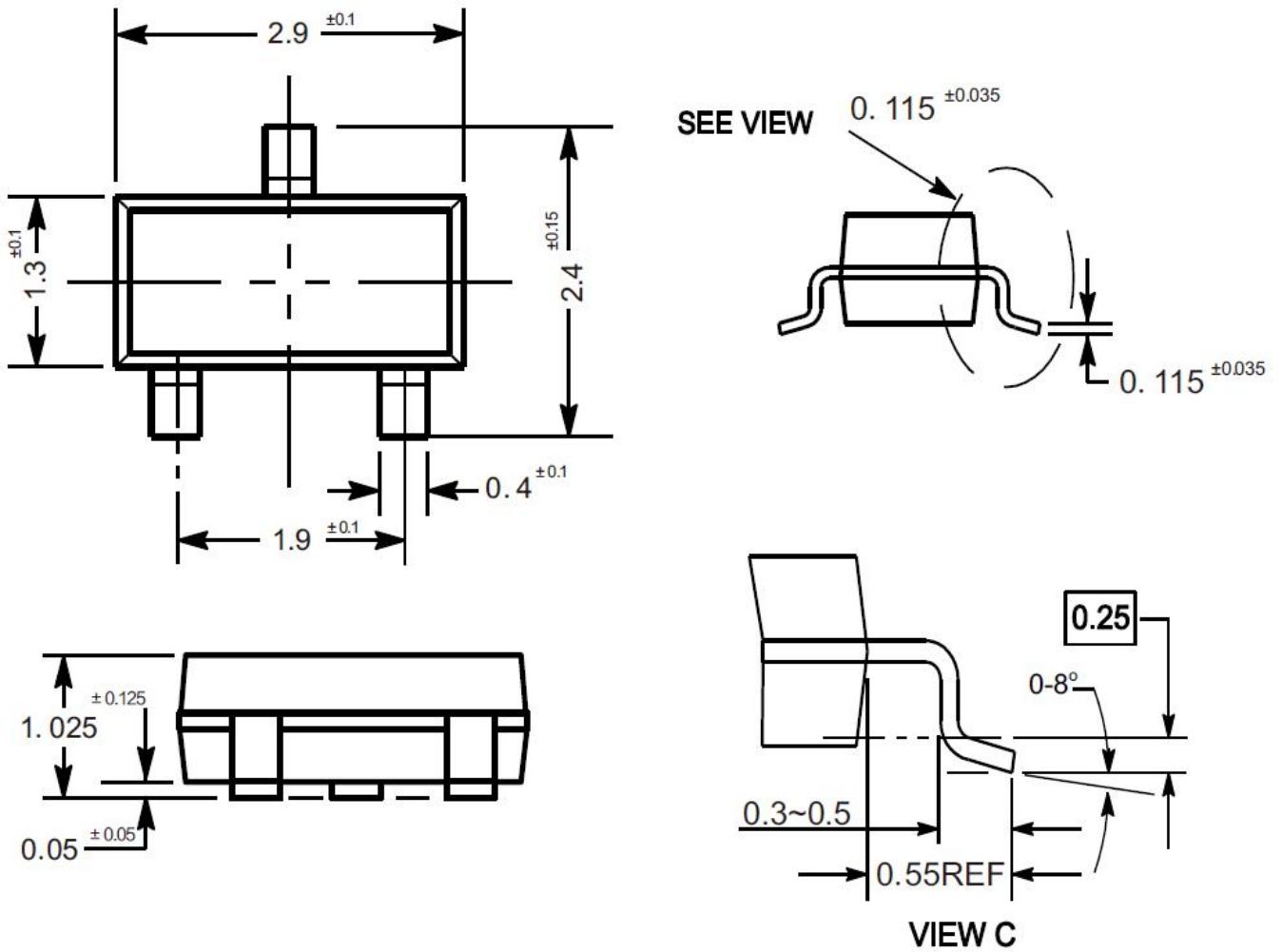

Ordering Information

Device	Package	Shipping
PJM2324NSA	SOT-23	3,000PCS/Reel&7inches



Conditions of Soldering and Storage

◆ Recommended condition of reflow soldering



Recommended peak temperature is over 245 °C. If peak temperature is below 245 °C, you may adjust the following parameters:

- Time length of peak temperature (longer)
- Time length of soldering (longer)
- Thickness of solder paste (thicker)

◆ Conditions of hand soldering

- Temperature: 370 °C
- Time: 3s max.
- Times: one time

◆ Storage conditions

- **Temperature**
5 to 40 °C
- **Humidity**
30 to 80% RH
- **Recommended period**
One year after manufacturing

Package Specifications

- The method of packaging

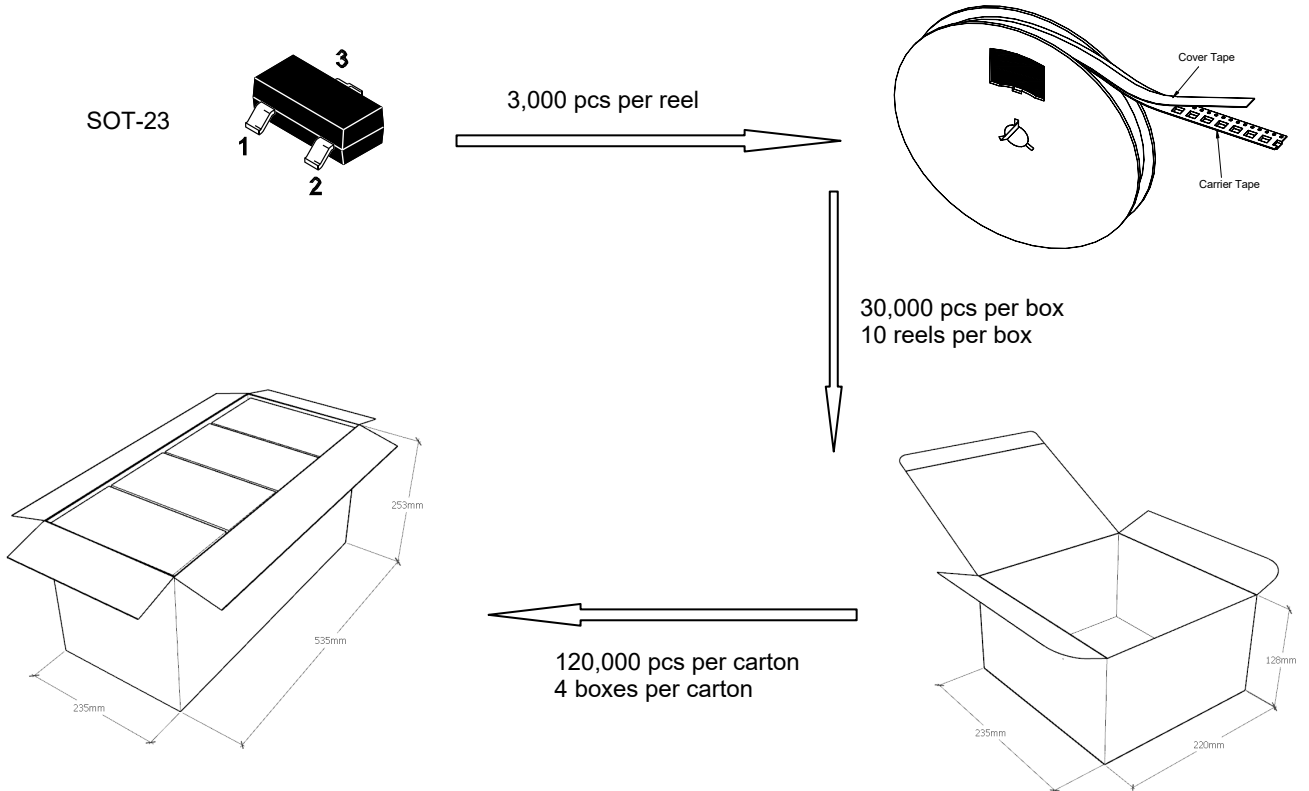

◆ Embossed tape and reel data

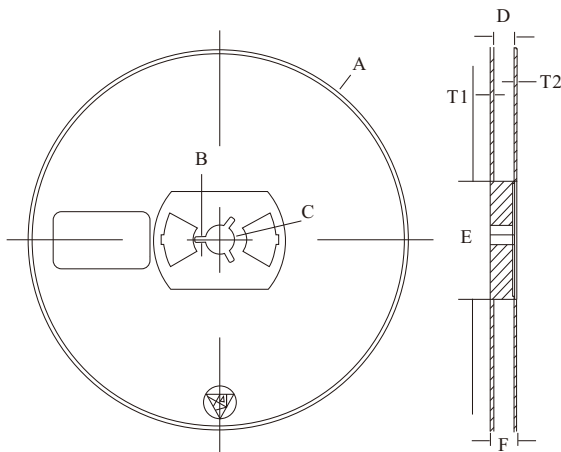

Symbol	Value (unit: mm)
A	Ø 177.8±1
B	2.7±0.2
C	Ø 13.5±0.2
E	Ø 54.5±0.2
F	12.3±0.3
D	9.6+2/-0.3
T1	1.0±0.2
T2	1.2±0.2

Reel (7")

