



# PJM7002KNSA

## N-Channel Enhancement Mode Power MOSFET

### Product Summary

- $V_{DS} = 60V, I_D = 0.3A$
- $R_{DS(on)} < 2.3\Omega @ V_{GS} = 10V$
- $R_{DS(on)} < 2.9\Omega @ V_{GS} = 4.5V$

### Features

- ESD Protected(HBM) up to 2KV
- Advanced Trench Technology
- RoHS and Reach Compliant
- Halogen and Antimony Free
- Moisture Sensitivity Level 1

### Application

- Battery Operated Systems
- Direct Logic-level Interface:TTL/CMOS
- Solid-State Relays

### Marking Code

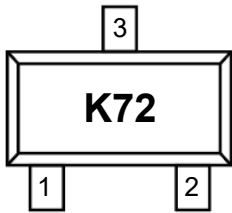

### SOT-23

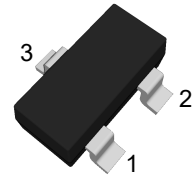

(Top View)

Pin	Description
1	Gate
2	Source
3	Drain

### Schematic Diagram

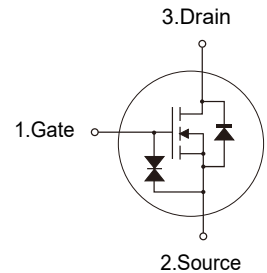

### Absolute Maximum Ratings

( $T_a = 25^\circ C$  unless otherwise specified)

Parameter	Symbol	Value	Unit
Drain-Source Voltage	$V_{DS}$	60	V
Gate-Source Voltage	$V_{GS}$	$\pm 20$	V
Drain Current-Continuous	$I_D$	0.3	A
Maximum Power Dissipation	$P_D$	0.35	W
Junction Temperature	$T_J$	150	$^\circ C$
Storage Temperature Range	$T_{STG}$	-55 to +150	$^\circ C$

### Thermal Characteristics

Thermal Resistance, Junction-to-Ambient <sup>Note1</sup>	$R_{\theta JA}$	357	$^\circ C/W$
--	-----------------	-----	--------------



# PJM7002KNSA

## N-Channel Enhancement Mode Power MOSFET

### Electrical Characteristics

(Ta=25°C unless otherwise specified)

Parameter	Symbol	Test Condition	Min.	Typ.	Max.	Unit
<b>Static Characteristics</b>						
Drain-Source Breakdown Voltage	$V_{(BR)DSS}$	$V_{GS}=0V, I_D=250\mu A$	60	--	--	V
Zero Gate Voltage Drain Current	$I_{DSS}$	$V_{DS}=60V, V_{GS}=0V$	--	--	1	$\mu A$
Gate-Body Leakage Current	$I_{GSS}$	$V_{GS}=\pm 20V, V_{DS}=0V$	--	--	$\pm 10$	$\mu A$
Gate Threshold Voltage <sup>Note2</sup>	$V_{GS(th)}$	$V_{DS}=V_{GS}, I_D=250\mu A$	1	1.5	2.5	V
Drain-Source On-Resistance <sup>Note2</sup>	$R_{DS(on)}$	$V_{GS}=10V, I_D=0.3A$	--	1.8	2.3	$\Omega$
		$V_{GS}=4.5V, I_D=0.2A$	--	2	2.9	$\Omega$
Forward Transconductance <sup>Note2</sup>	$g_{FS}$	$V_{DS}=5V, I_D=0.2A$	--	0.35	--	S
<b>Dynamic Characteristics</b>						
Input Capacitance	$C_{iss}$	$V_{DS}=15V, V_{GS}=0V, f=1MHz$	--	31	--	pF
Output Capacitance	$C_{oss}$		--	11	--	pF
Reverse Transfer Capacitance	$C_{rss}$		--	6.5	--	pF
Total Gate Charge	$Q_g$	$V_{DS}=10V, I_D=0.3A,$ $V_{GS}=4.5V$	--	1.7	--	nC
Gate-Source Charge	$Q_{gs}$		--	0.3	--	nC
Gate-Drain Charge	$Q_{gd}$		--	0.6	--	nC
<b>Switching Characteristics</b>						
Turn-on Delay Time	$t_{d(on)}$	$V_{DD}=10V, I_D=0.2A,$ $V_{GS}=10V, R_{GEN}=10\Omega$	--	2	--	nS
Turn-on Rise Time	$t_r$		--	15	--	nS
Turn-off Delay Time	$t_{d(off)}$		--	7	--	nS
Turn-off Fall Time	$t_f$		--	20	--	nS
<b>Source-Drain Diode Characteristics</b>						
Diode Forward Voltage <sup>Note2</sup>	$V_{SD}$	$V_{GS}=0V, I_S=0.3A$	--	--	1.2	V
Diode Forward Current <sup>Note1</sup>	$I_S$		--	--	0.3	A

Note: 1. Surface Mounted on FR4 Board,  $t \leq 10$  sec.  
2. Pulse Test: Pulse width  $\leq 300\mu s$ , duty cycle  $\leq 2\%$ .



# PJM7002KNSA

## N-Channel Enhancement Mode Power MOSFET

### Typical Characteristic Curves

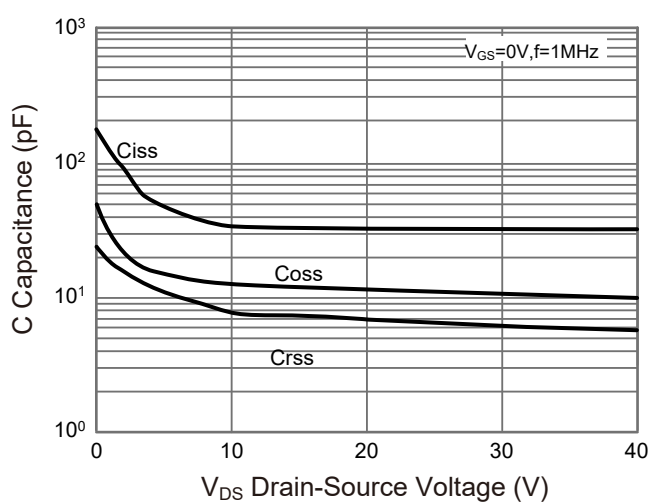
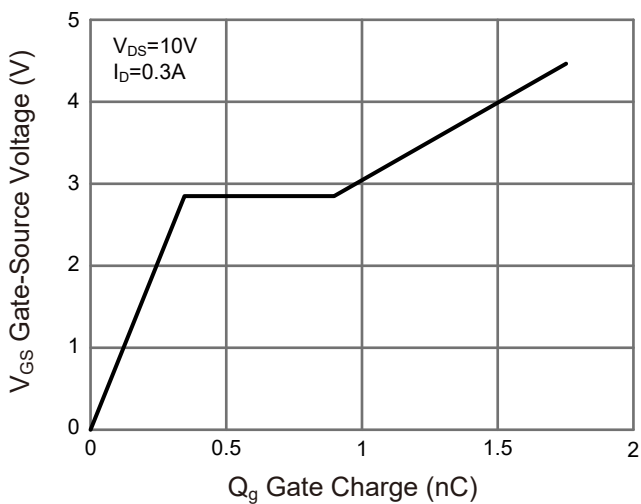
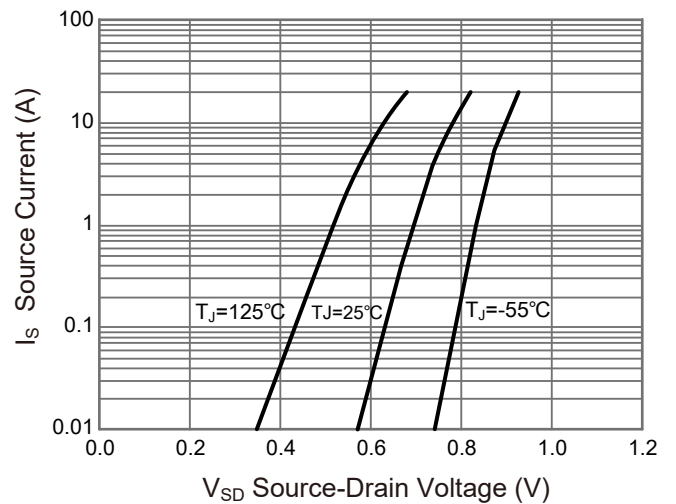
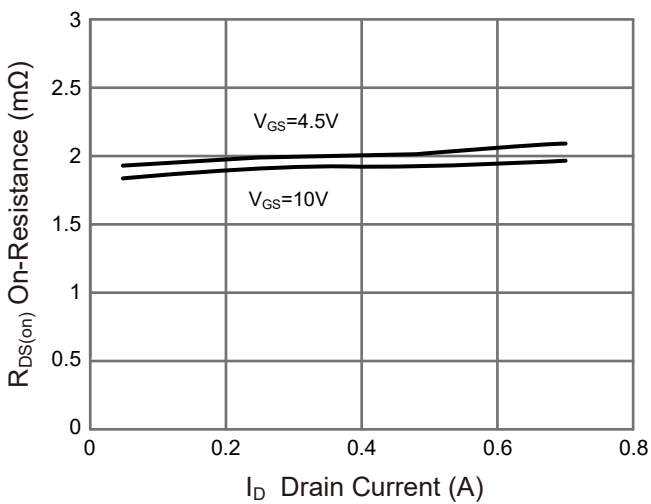
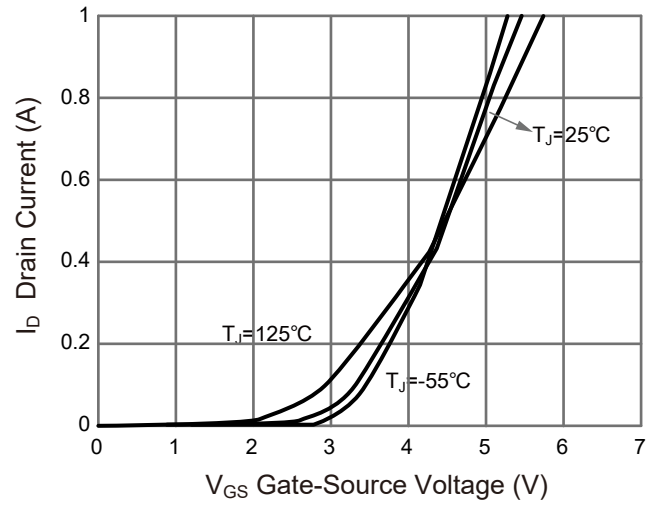
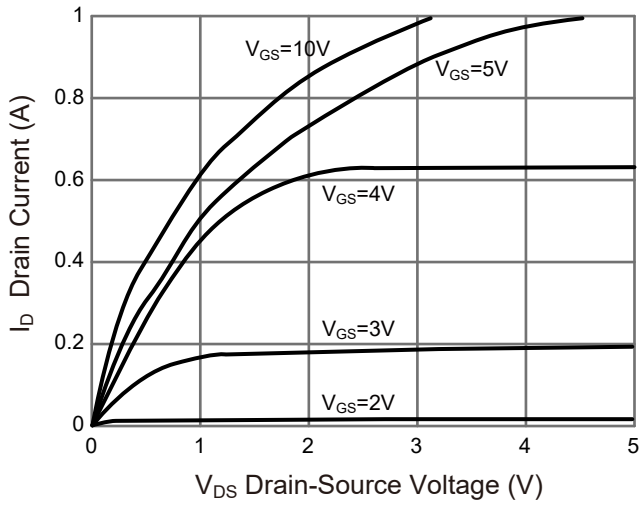



# PJM7002KNSA

## N-Channel Enhancement Mode Power MOSFET

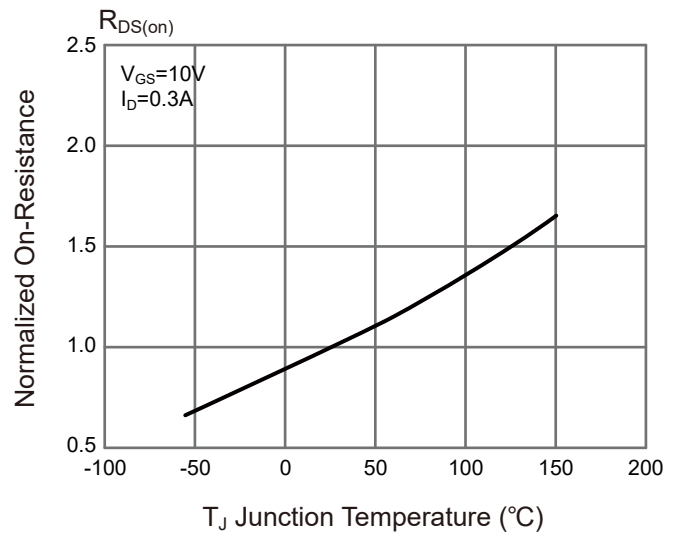
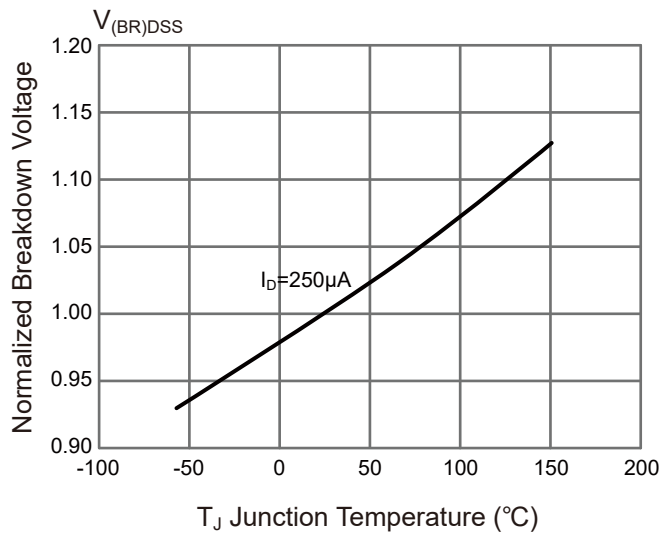



# PJM7002KNSA

## N-Channel Enhancement Mode Power MOSFET

### Package Outline

SOT-23

Dimensions in mm

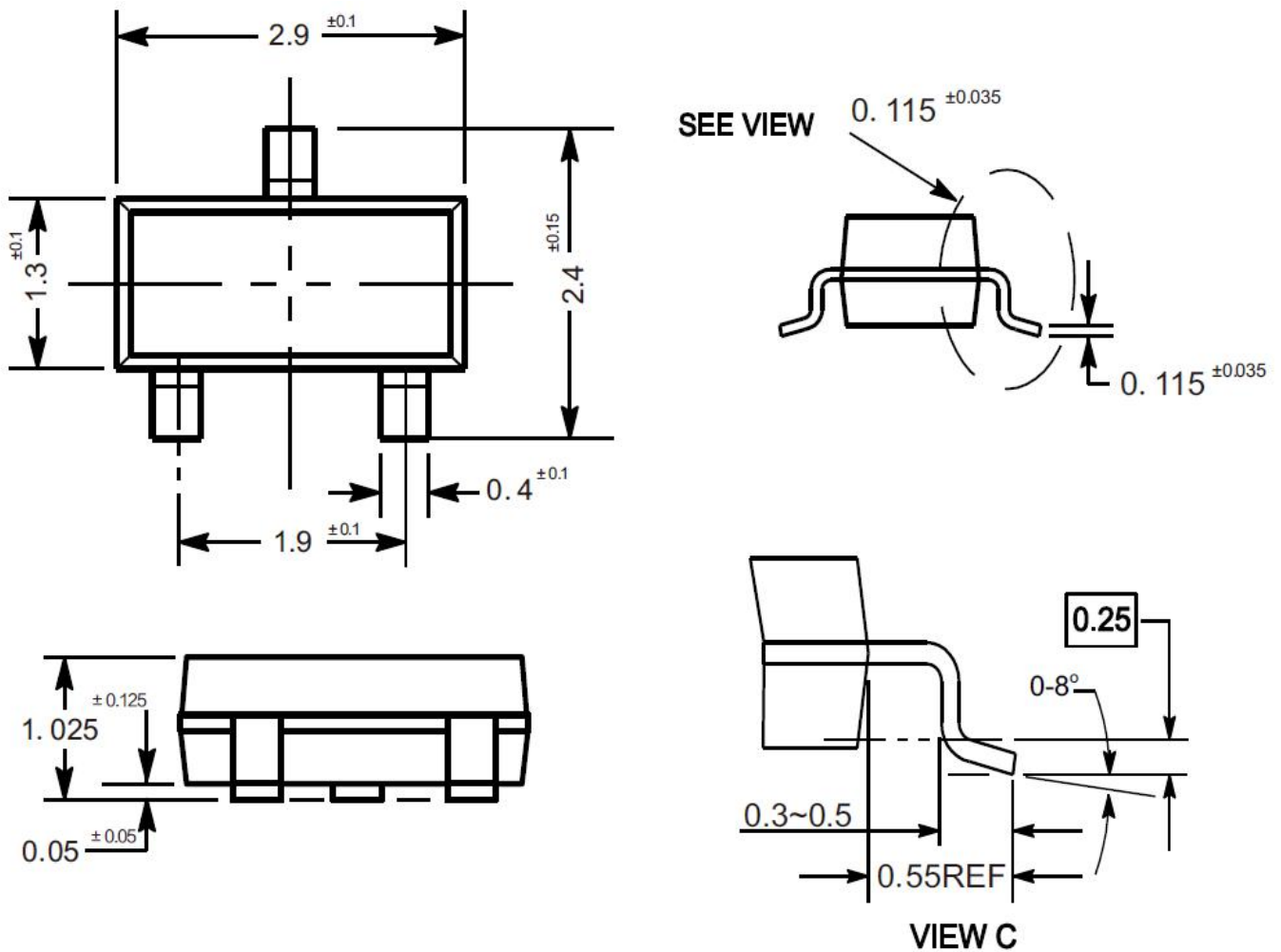

### Ordering Information

Device	Package	Shipping
PJM7002KNSA	SOT-23	3,000PCS/Reel&7inches



### Conditions of Soldering and Storage

#### ◆ Recommended condition of reflow soldering

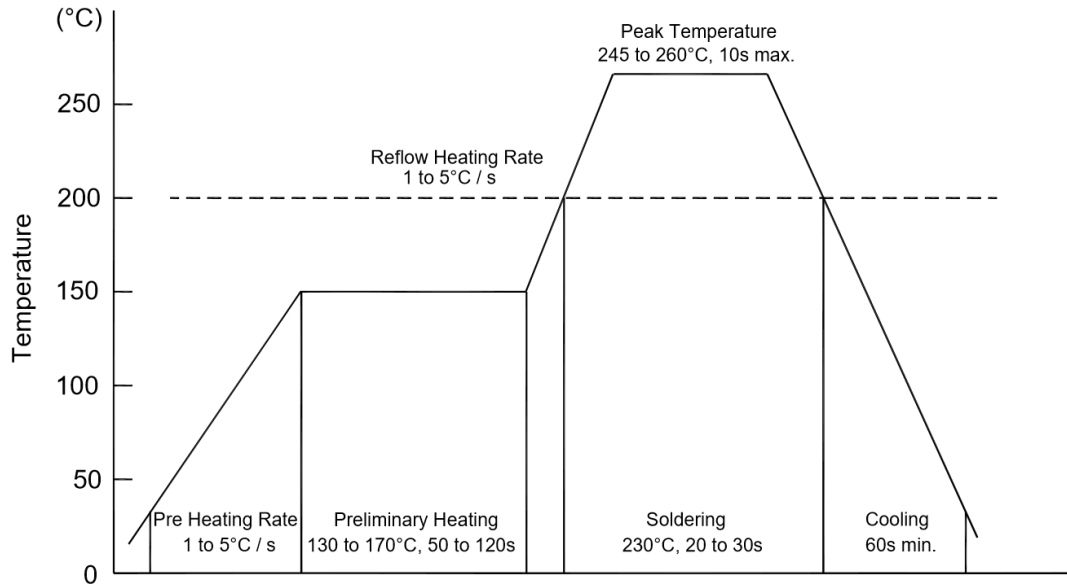

Recommended peak temperature is over 245°C. If peak temperature is below 245°C, you may adjust the following parameters:

- Time length of peak temperature (longer)
- Time length of soldering (longer)
- Thickness of solder paste (thicker)

#### ◆ Conditions of hand soldering

- Temperature: 300°C
- Time: 3s max.
- Times: one time

#### ◆ Storage conditions

- **Temperature**  
5 to 40°C
- **Humidity**  
30 to 80% RH
- **Recommended period**  
One year after manufacturing



# PJM7002KNSA

## N-Channel Enhancement Mode Power MOSFET

### Package Specifications

- The method of packaging

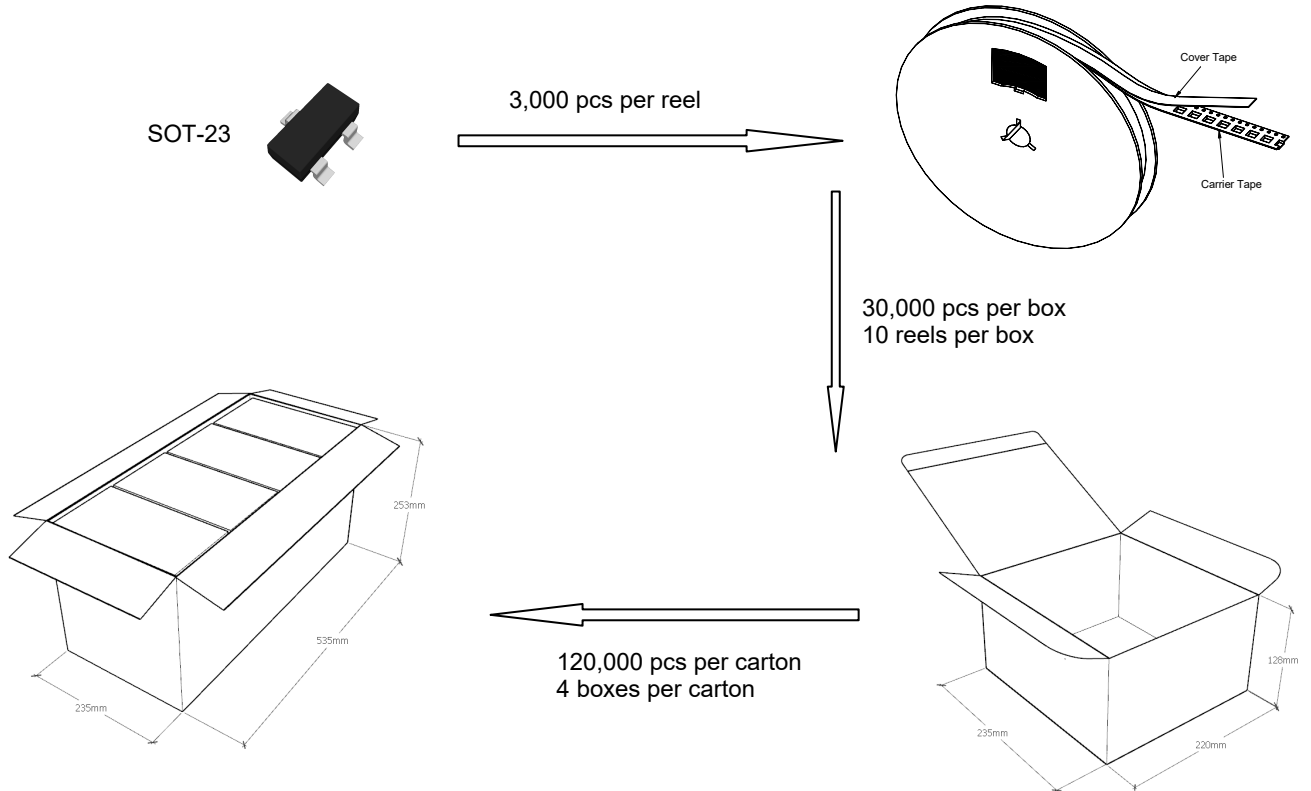

### ◆ Embossed tape and reel data

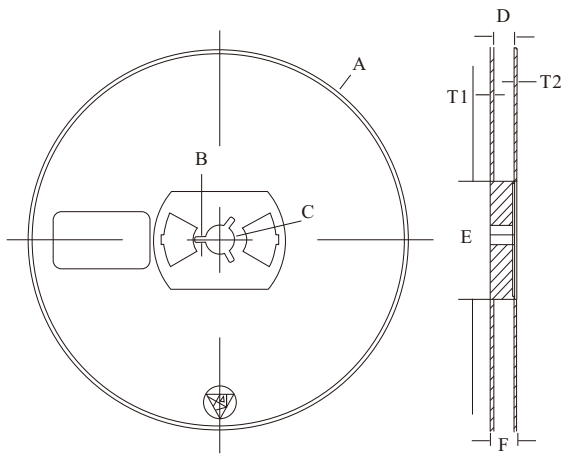

Symbol	Value (unit: mm)
A	Ø 177.8±1
B	2.7±0.2
C	Ø 13.5±0.2
E	Ø 54.5±0.2
F	12.3±0.3
D	9.6+2/-0.3
T1	1.0±0.2
T2	1.2±0.2

Reel (7")

