



PJM80H10NTF

N-Channel Enhancement Mode Power MOSFET

Features

- Fast Switching
- Low Reverse transfer capacitances
- Low gate charge and low $R_{DS(on)}$
- $V_{DS} = 800V, I_D = 10A$
 $R_{DS(on)} < 1.15\Omega @ V_{GS} = 10V$

Applications

- Power switch circuit of adaptor and charger

TO-220F

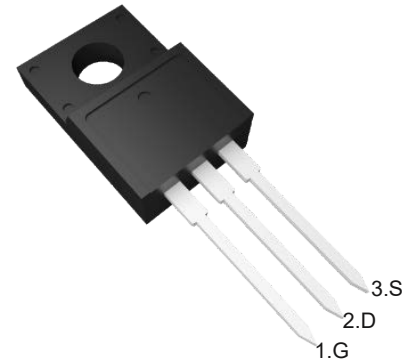

1.Gate 2.Drain 3.Source

Schematic diagram

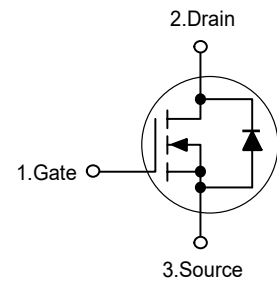

Absolute Maximum Ratings

Ratings at 25°C case temperature unless otherwise specified.

Parameter	Symbol	Value	Unit
Drain-Source Voltage	V_{DS}	800	V
Gate-Source Voltage	V_{GS}	±30	V
Drain Current-Continuous	I_D	10	A
Drain Current-Pulsed ^{Note1}	I_{DM}	40	A
Single pulse avalanche energy ^{Note4}	E_{AS}	460	mJ
Maximum Power Dissipation	P_D	55	W
Junction Temperature	T_J	150	°C
Storage Temperature Range	T_{STG}	-55 to +150	°C

Thermal Characteristics

Thermal Resistance, Junction-to-Ambient ^{Note2}	$R_{\theta JA}$	100	°C/W
Maximum Junction-to-Case ^{Note2}	$R_{\theta JC}$	2.27	°C/W



PJM80H10NTF

N-Channel Enhancement Mode Power MOSFET

Electrical Characteristics

(Ta=25°C unless otherwise specified)

Parameter	Symbol	Test Condition	Min.	Typ.	Max.	Unit
Static Characteristics						
Drain-Source Breakdown Voltage	$V_{(BR)DSS}$	$V_{GS}=0V, I_D=250\mu A$	800	--	--	V
Zero Gate Voltage Drain Current	I_{DSS}	$V_{DS}=800V, V_{GS}=0V$	--	--	1	μA
Gate-Body Leakage Current	I_{GSS}	$V_{GS}=\pm 30V, V_{DS}=0V$	--	--	± 100	nA
Gate Threshold Voltage ^{Note3}	$V_{GS(th)}$	$V_{DS}=V_{GS}, I_D=250\mu A$	2.0	--	4.0	V
Drain-Source On-Resistance ^{Note3}	$R_{DS(on)}$	$V_{GS}=10V, I_D=4A$	--	1	1.15	Ω
Forward Transconductance ^{Note3}	g_{FS}	$V_{DS}=20V, I_D=10A$	--	20	--	S
Dynamic Characteristics						
Input Capacitance	C_{iss}	$V_{DS}=25V, V_{GS}=0V, f=1MHz$	--	2900	--	pF
Output Capacitance	C_{oss}		--	200	--	pF
Reverse Transfer Capacitance	C_{rss}		--	25	--	pF
Switching Characteristics						
Turn-on Delay Time	$t_{d(on)}$	$V_{DD}=400V, I_D=10A$ $V_{GS}=10V, R_G=4.7\Omega$	--	19	--	nS
Turn-on Rise Time	t_r		--	10	--	nS
Turn-off Delay Time	$t_{d(off)}$		--	68	--	nS
Turn-off Fall Time	t_f		--	23	--	nS
Total Gate Charge	Q_g	$V_{DD}=640V, I_D=10A, V_{GS}=10V$	--	60	--	nC
Gate-Source Charge	Q_{gs}		--	13	--	nC
Gate-Drain Charge	Q_{gd}		--	22	--	nC
Source-Drain Diode Characteristics						
Diode Forward Voltage ^{Note3}	V_{SD}	$V_{GS}=0V, I_S=10A$	--	--	1.5	V
Diode Forward Current ^{Note2}	I_S		--	--	10	A

Note: 1. Repetitive Rating: Pulse width limited by maximum junction temperature.

2. Surface Mounted on FR4 Board, $t \leq 10$ sec.

3. Pulse Test: Pulse width $< 380\mu s$, duty cycle $< 2\%$.

4. E_{AS} Condition: $L=10mH, I_D=9.5A$, start $T_J=25^\circ C$.



PJM80H10NTF

N-Channel Enhancement Mode Power MOSFET

Typical Characteristic Curves

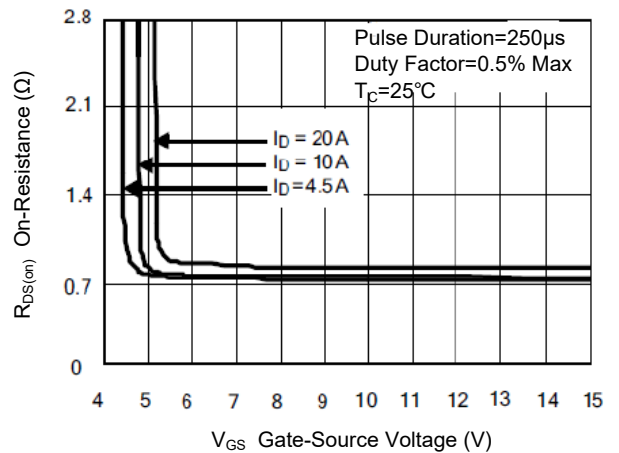
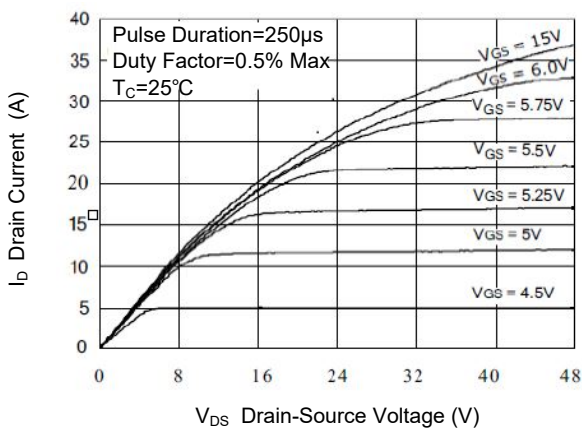
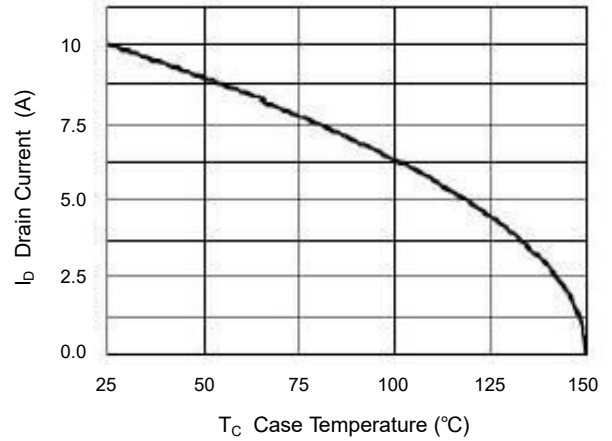
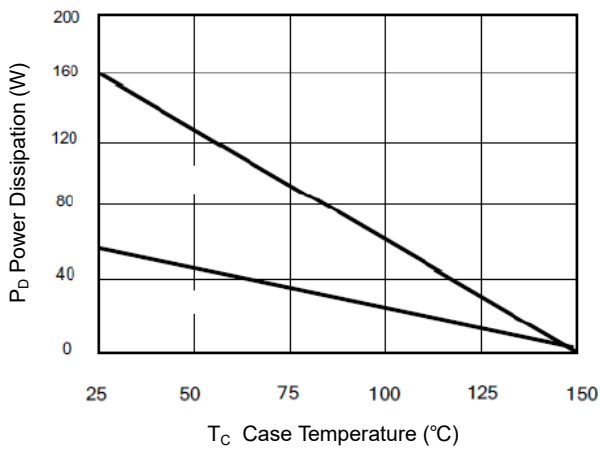
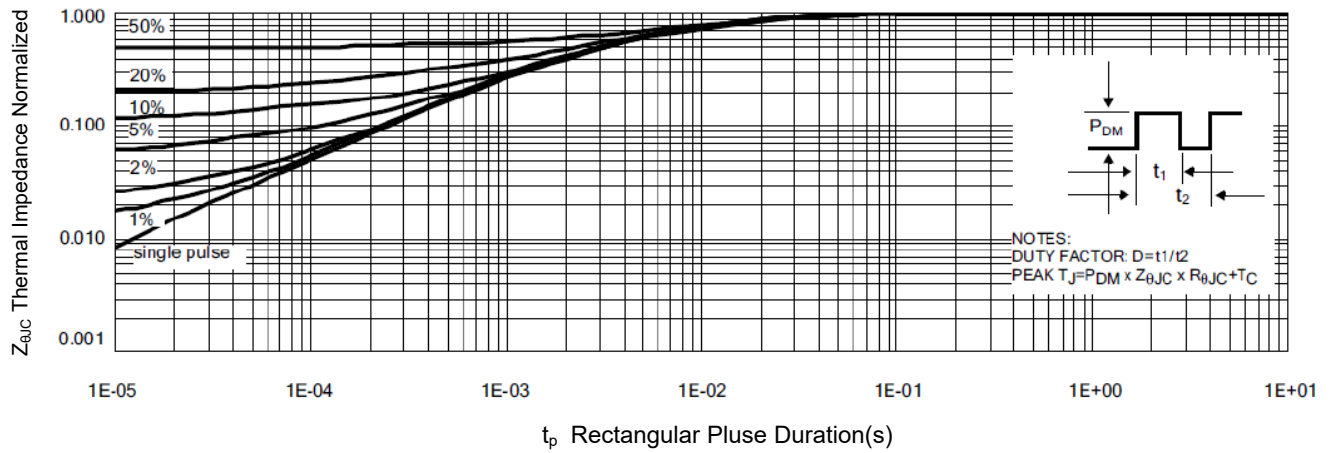



PJM80H10NTF

N-Channel Enhancement Mode Power MOSFET

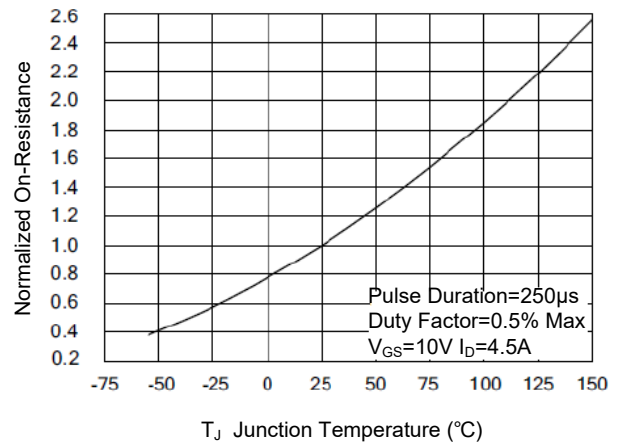
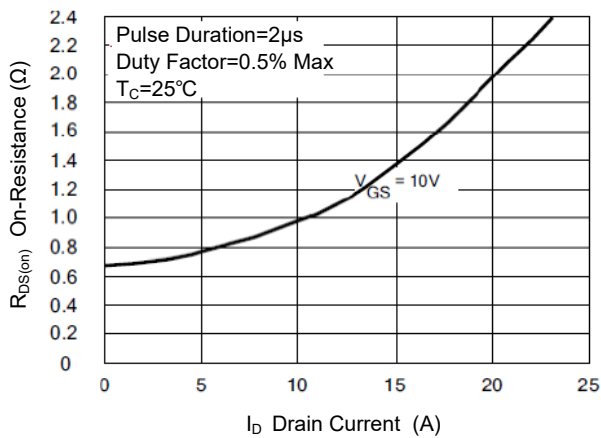
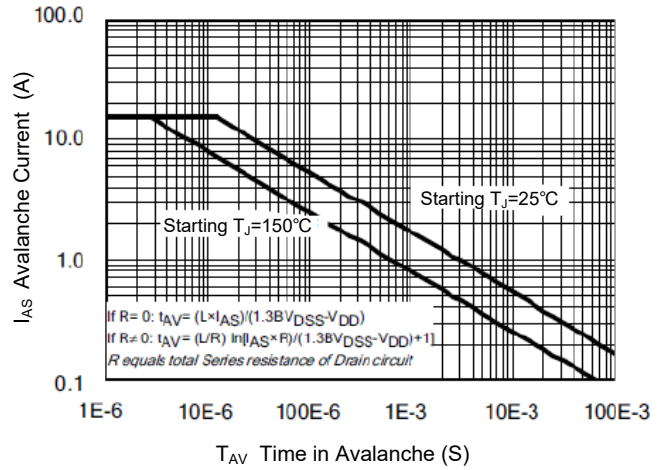
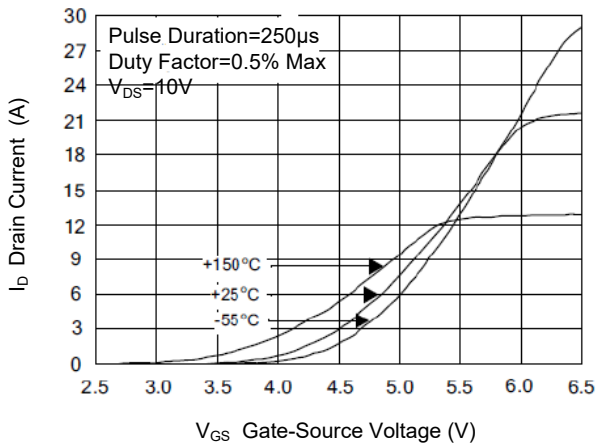
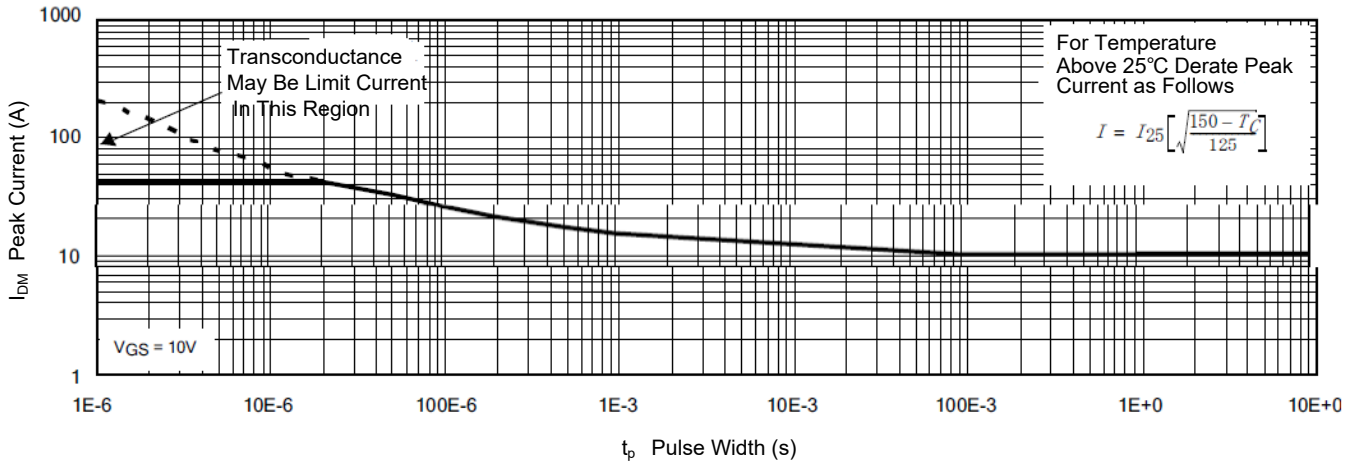



PJM80H10NTF

N-Channel Enhancement Mode Power MOSFET

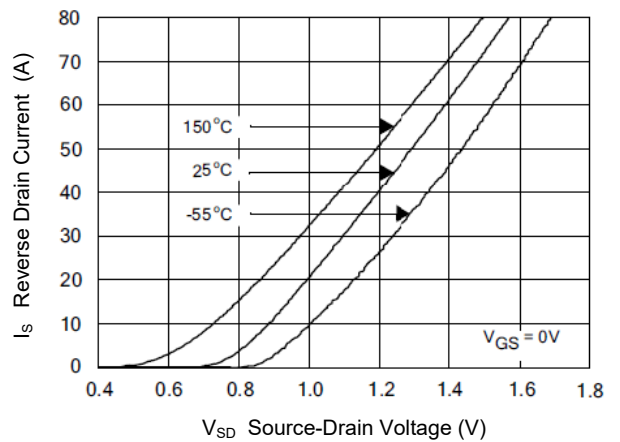
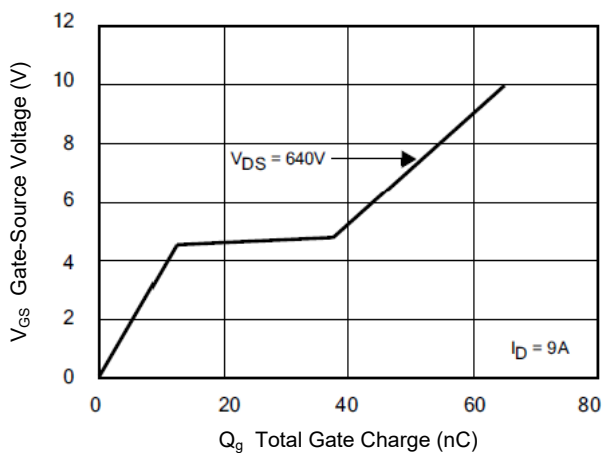
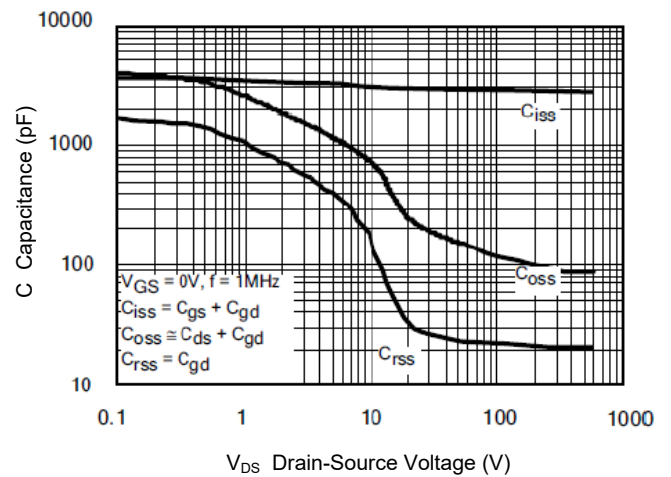
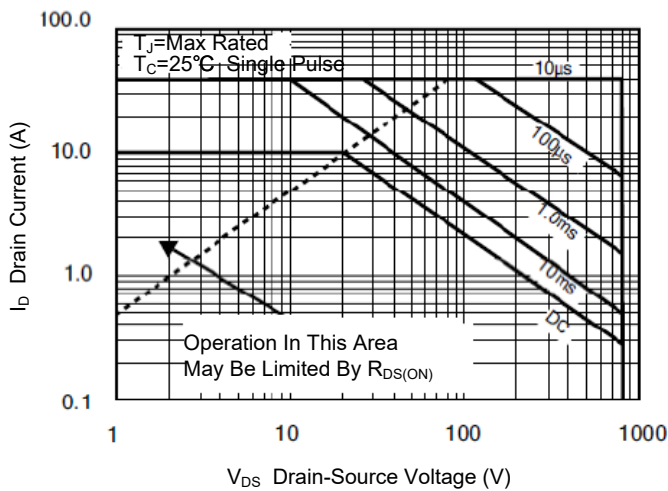
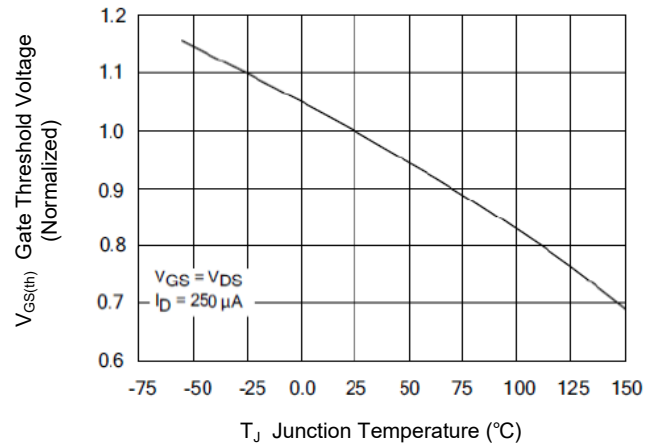
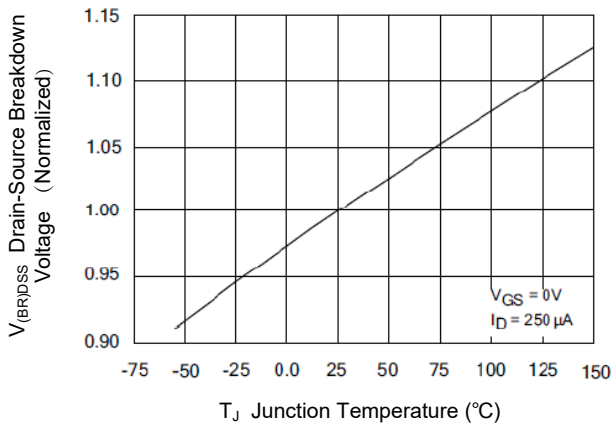



PJM80H10NTF

N-Channel Enhancement Mode Power MOSFET

Package Outline

TO-220F

Dimensions in mm

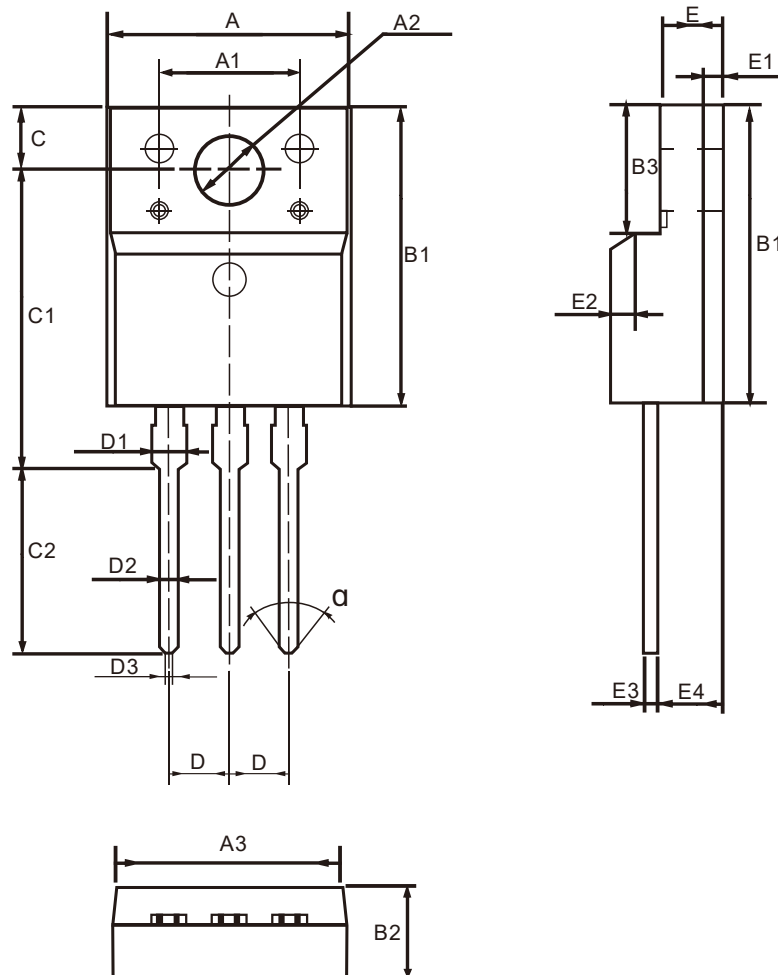

TO-220F Package Dimensions

UNIT : mm

SYMBOL	min	nom	max	SYMBOL	min	nom	max
A	9.80		10.60	D		2.54	
A1		7.00		D1	1.15		1.55
A2	2.90		3.40	D2	0.60		1.00
A3	9.10		9.90	D3	0.20		0.50
B1	15.40		16.40	E	2.24		2.84
B2	4.35		4.95	E1		0.70	
B3	6.00		7.40	E2		1.0 × 45°	
C	3.00		3.70	E3	0.35		0.65
C1	15.00		17.00	E4	2.30		3.30
C2	8.80		10.80	α (度)		30°	