



# SB32FL~SB320FL Schottky Barrier Diodes

## Features

- For surface mount applications
- High forward surge current capability
- Low power loss, high efficiency

SOD-123FL



1.Cathode  2.Anode

## Marking Code :

SB32FL : S32  
SB34FL : S34  
SB36FL : S36  
SB38FL : S38  
SB310FL : S310  
SB312FL : S312  
SB315FL : S315  
SB320FL : S320

## Maximum Ratings and Electrical Characteristics

Ratings at 25°C ambient temperature unless otherwise specified.

Parameter	Symbol	SB32FL	SB34FL	SB36FL	SB38FL	SB310FL	SB312FL	SB315FL	SB320FL	Unit
Maximum Repetitive Peak Reverse Voltage	$V_{RRM}$	20	40	60	80	100	120	150	200	V
Maximum RMS Voltage	$V_{RMS}$	14	28	42	56	70	84	105	140	V
Maximum DC Blocking Voltage	$V_{DC}$	20	40	60	80	100	120	150	200	V
Maximum Average Forward Rectified Current	$I_{F(AV)}$	3.0								A
Peak Forward Surge Current, 8.3ms Single Half Sine-wave Superimposed on Rated Load (JEDEC method)	$I_{FSM}$	80								A
Maximum Instantaneous Forward Voltage at 3 A	$V_F$	0.55	0.70		0.85		0.95		V	
Maximum DC Reverse Current at Rated DC Blocking Voltage $T_A = 25\text{ }^\circ\text{C}$ $T_A = 100\text{ }^\circ\text{C}$	$I_R$	0.5	10		0.3		5		mA	
Typical Junction Capacitance <sup>Note1</sup>	$C_J$	250	160							pF
Typical Thermal Resistance <sup>Note2</sup>	$R_{\theta JA}$	80								$^\circ\text{C/W}$
Operating Junction Temperature Range	$T_J$	-55 to +150								$^\circ\text{C}$
Storage Temperature Range	$T_{STG}$	-55 to +150								$^\circ\text{C}$

## Note:

1. Measured at 1 MHz and applied reverse voltage of 4 V DC.
2. P.C.B. mounted with 2.0" X 2.0" (5 X 5 cm) copper pad areas.



# SB32FL~SB320FL Schottky Barrier Diodes

## Typical Characteristic Curves

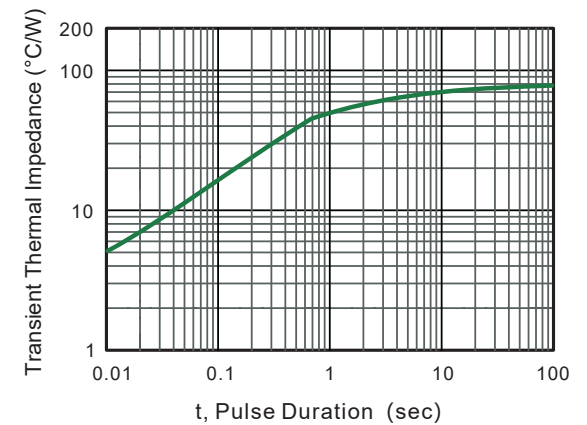
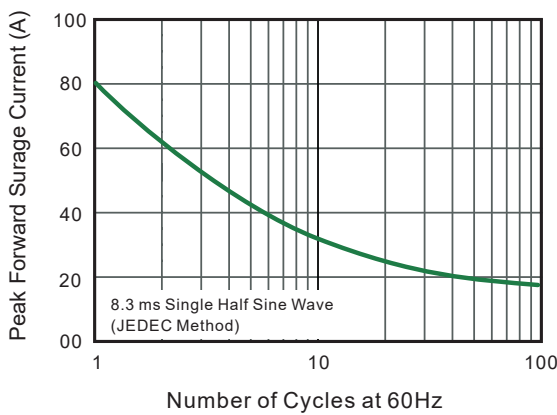
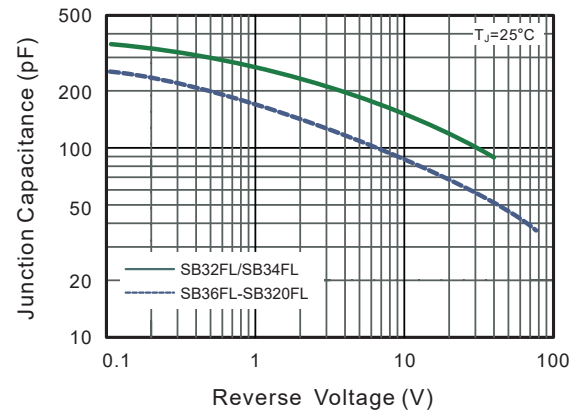
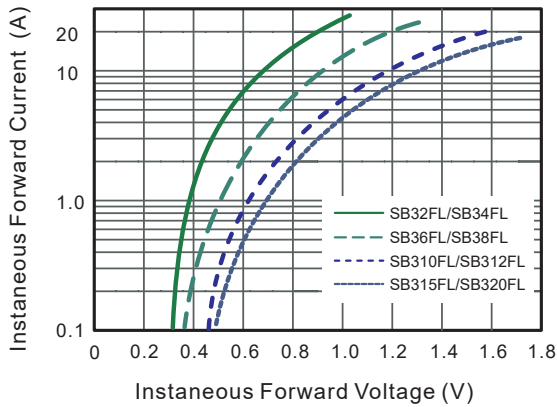
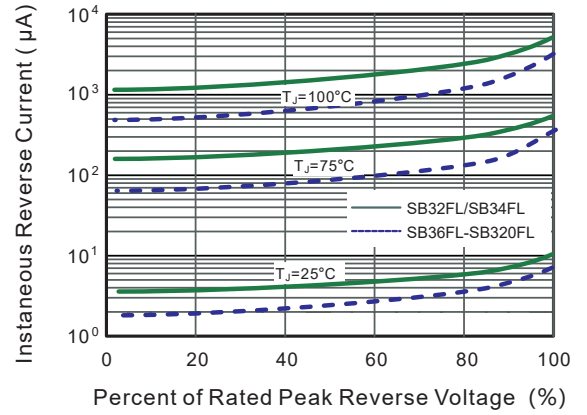
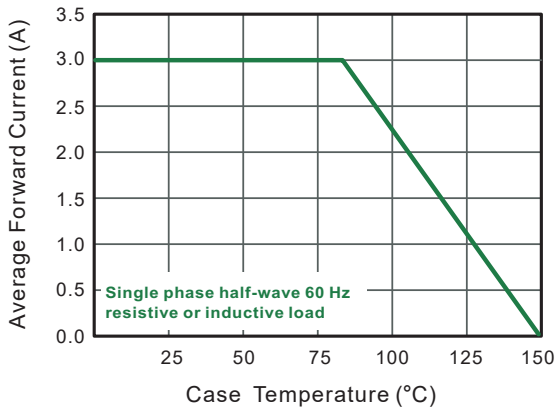

### Package Outline

SOD-123FL

Dimensions in mm

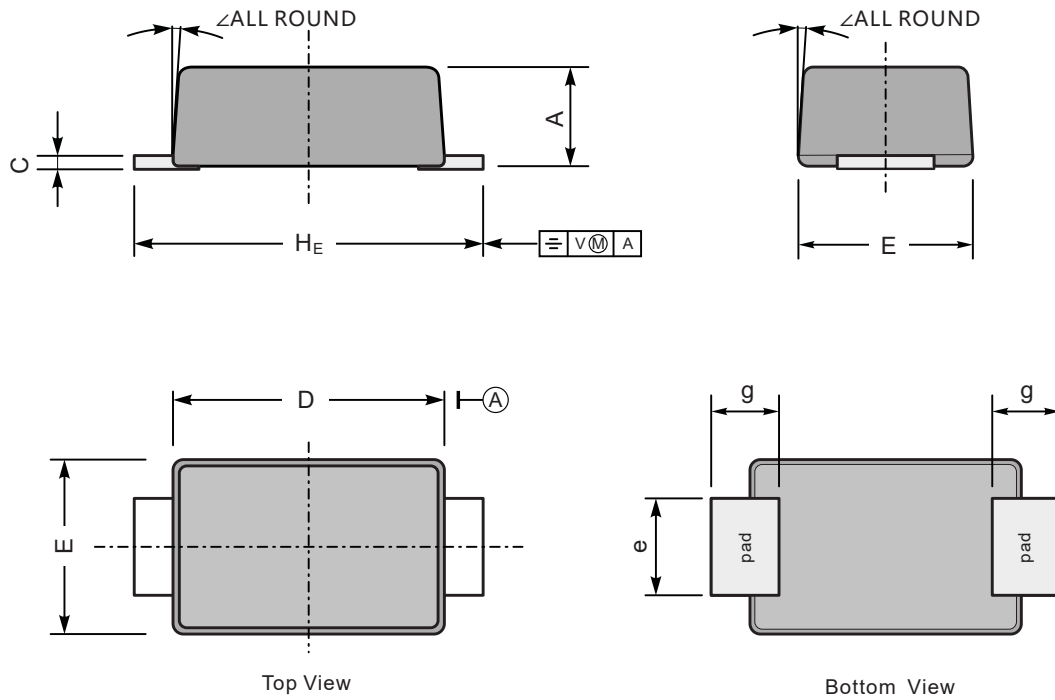

UNIT		A	C	D	E	e	g	$E_H$	$\angle$
mm	max	1.1	0.20	2.9	1.9	1.1	0.9	3.8	7°
	min	0.9	0.12	2.6	1.7	0.8	0.7	3.5	
mil	max	43	7.9	114	75	43	35	150	
	min	35	4.7	102	67	31	28	138	