



# SS52B-PJ~SS520B-PJ Schottky Barrier Rectifiers

## Features

- For surface mount applications
- High forward surge current capability
- Low profile package
- High efficiency
- Metal silicon junction, majority carriers conduction

## SMB

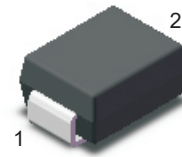

## Marking Code :

SS52B-PJ: SS52  
 SS54B-PJ: SS54  
 SS56B-PJ: SS56  
 SS58B-PJ: SS58  
 SS510B-PJ: SS510  
 SS512B-PJ: SS512  
 SS515B-PJ: SS515  
 SS520B-PJ: SS520

## Maximum Ratings and Electrical Characteristics

Ratings at 25°C ambient temperature unless otherwise specified. Single phase half-wave 60 Hz, resistive or inductive load, for capacitive load current derate by 20 %.

| Parameter   | Symbol          | SS52B-PJ    | SS54B-PJ | SS56B-PJ | SS58B-PJ | SS510B-PJ | SS512B-PJ | SS515B-PJ | SS520B-PJ | Unit               |
|---|-----------------|-------------|----------|----------|----------|-----------|-----------|-----------|-----------|--------------------|
| Maximum Repetitive Peak Reverse Voltage   | $V_{RRM}$       | 20          | 40       | 60       | 80       | 100       | 120       | 150       | 200       | V                  |
| Maximum RMS Voltage   | $V_{RMS}$       | 14          | 28       | 42       | 56       | 70        | 84        | 105       | 140       | V                  |
| Maximum DC Blocking Voltage   | $V_{DC}$        | 20          | 40       | 60       | 80       | 100       | 120       | 150       | 200       | V                  |
| Maximum Average Forward Rectified Current<br>$T_C = 90^\circ\text{C}$   | $I_{F(AV)}$     | 5.0         |          |          |          |           |           |           |           | A                  |
| Peak Forward Surge Current, 8.3ms<br>Single Half Sine-wave Superimposed<br>on Rated Load (JEDEC method)             | $I_{FSM}$       | 150         |          |          |          |           |           |           |           | A                  |
| Maximum Instantaneous Forward Voltage at 5 A  | $V_F$           | 0.55        | 0.70     |          | 0.85     |           |           |           | V         |                    |
| Maximum DC Reverse Current<br>at Rated DC Blocking Voltage<br>$T_A = 25^\circ\text{C}$<br>$T_A = 100^\circ\text{C}$ | $I_R$           | 1.0         | 50       |          | 0.3      |           |           |           | 25        | mA                 |
| Typical Junction Capacitance <sup>Note1</sup>   | $C_j$           | 500         | 300      |          | pF       |           |           |           |           |                    |
| Typical Thermal Resistance <sup>Note2</sup>   | $R_{\theta JA}$ | 50          |          |          |          |           |           |           |           | $^\circ\text{C/W}$ |
| Junction Temperature  | $T_J$           | 150         |          |          |          |           |           |           |           | $^\circ\text{C}$   |
| Storage Temperature Range   | $T_{STG}$       | -55 to +150 |          |          |          |           |           |           |           | $^\circ\text{C}$   |

## Note:

1. Measured at 1 MHz and applied reverse voltage of 4 V D.C
2. P.C.B. mounted with 2.0" X 2.0" (5 X 5 cm) copper pad areas.



# SS52B-PJ~SS520B-PJ Schottky Barrier Rectifiers

## Typical Characteristic Curves

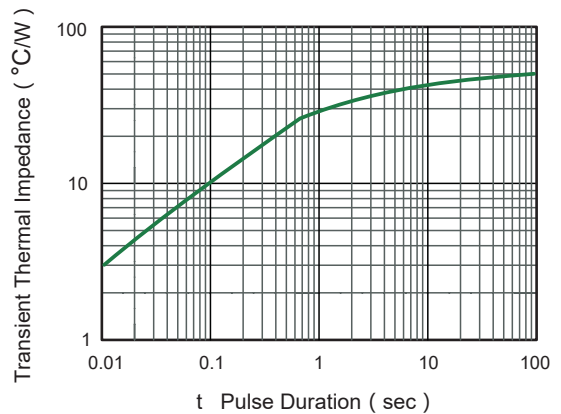
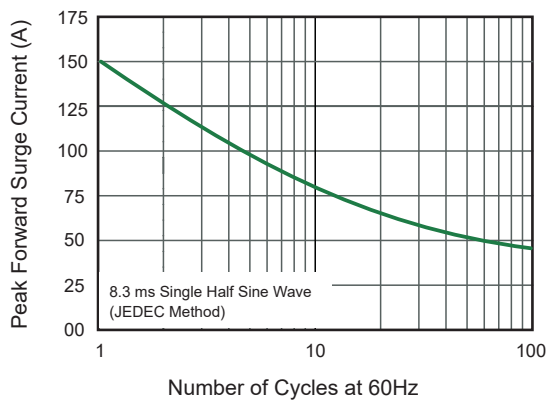
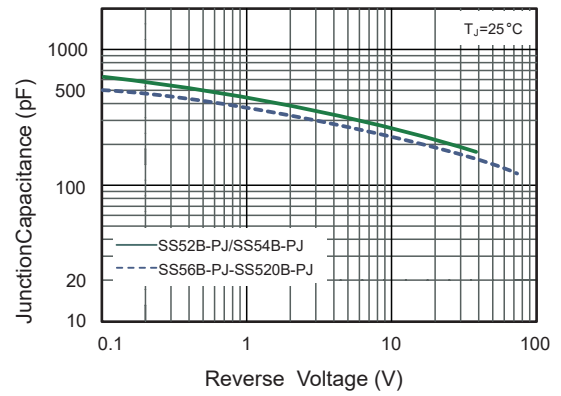
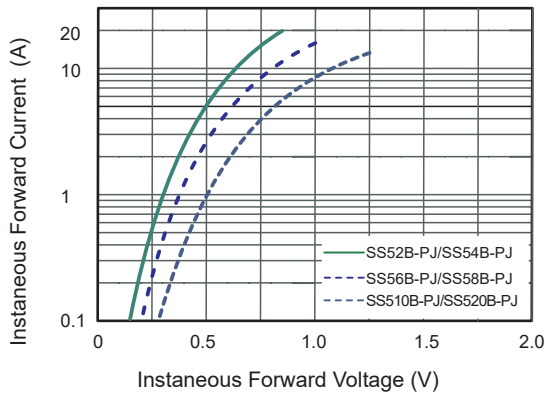
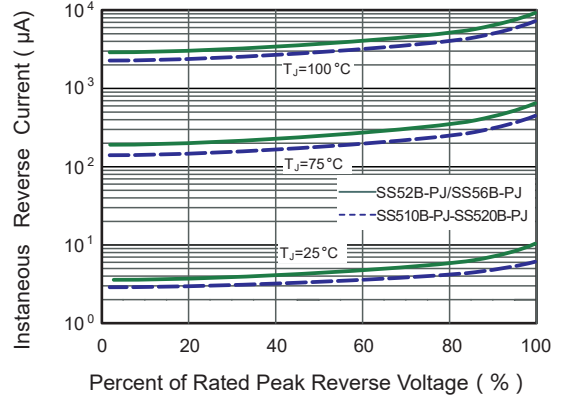
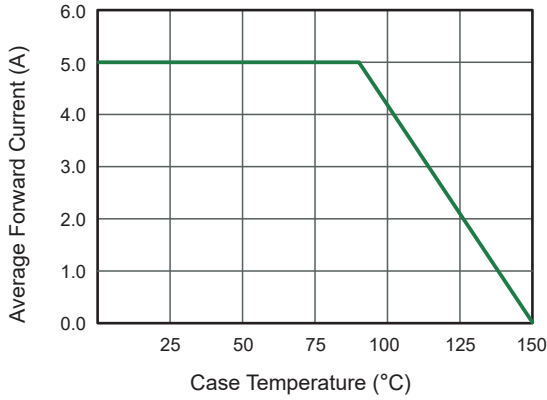



# SS52B-PJ~SS520B-PJ Schottky Barrier Rectifiers

## Package Outline

SMB

Dimensions in mm

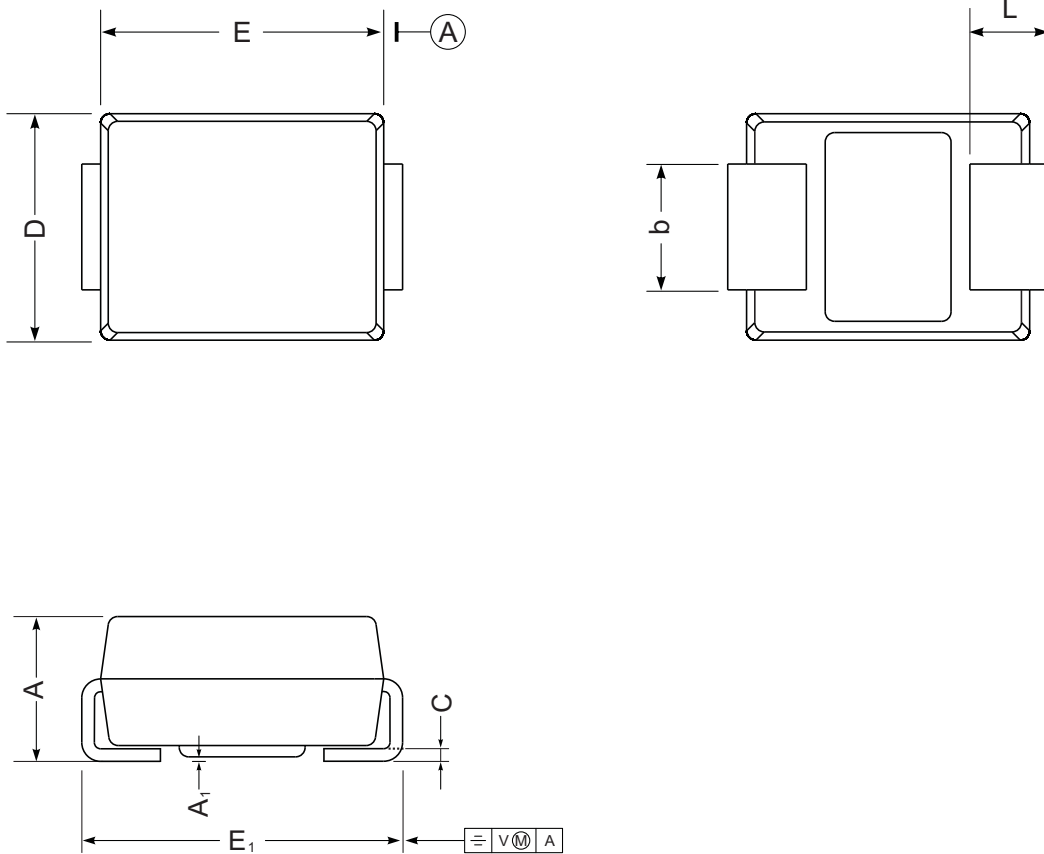

| UNIT |     | A    | E    | D    | E1   | A1   | L   | C     | b   |
|------|-----|------|------|------|------|------|-----|-------|-----|
| mm   | max | 2.44 | 4.70 | 3.94 | 5.59 | 0.20 | 1.5 | 0.305 | 2.2 |
|      | min | 2.13 | 4.06 | 3.3  | 5.08 | 0.05 | 0.8 | 0.152 | 1.9 |
| mil  | max | 96   | 185  | 155  | 220  | 7.9  | 59  | 12    | 87  |
|      | min | 84   | 160  | 130  | 200  | 2.0  | 32  | 6     | 75  |